



MODEL HW INSTALLATION, OPERATION & MAINTENANCE MANUAL



Low Temperature
High Wall Heating/Cooling Fan Coil
Units up to 2 Ton Capacity



INVESTING IN QUALITY, RELIABILITY & PERFORMANCE.

ISO 9001 QUALITY



Management Service

Every product is manufactured to meet the stringent requirements of the internationally recognized ISO 9001 standard for quality assurance in design, development and production.

World Leading Design and Technology

Equipped with the latest air-conditioning test rooms and manufacturing technology, our factories in China produce over 2,000,000 air conditioning units each year, all conforming to the highest international standards of quality and safety.

ETL SAFETY STANDARDS



All products conform to UL standard for Safety for Heating and Cooling Equipment UL1995 4th Edition, October 14, 2011;

All products conform to CSA standard for Safety for Heating and Cooling Equipment CSA C22.2 No.236-11, 4th Edition, October 14 2011.

The Highest Standards of Manufacturing

In order to guarantee the very highest standards and performance, we manage every stage in the manufacturing of our products. Throughout the production process we maintain strict control, starting with our extensive resources in research and development through to the design and manufacture of almost every individual component, from molded plastics to the assembly of units and controllers.

WEEE MARK



All products conform to the "WEEE" directive to guarantee correct standards of environmental solutions.

Quality Controlled from Start to Finish

Our highly trained staff and strict quality control methods enable us to produce products with an exceptional reputation for reliability and efficiency, maintained over many years. As well as full CE certification and ISO 9001, several products ranges have UL / ETL safety approval in the USA and Canada, ROHS compliance for Europe, giving you the confidence of knowing our company is the right choice when selecting air conditioning equipment.

ALWAYS MAKE SURE THIS MANUAL REMAINS WITH THE UNIT. READ THIS MANUAL BEFORE PERFORMING ANY OPERATION ON THE UNIT.

Table of Content

A.	GENERAL DESCRIPTION	4
B.	TECHNICAL DATA	5
B.1.	GENERAL SPECIFICATION	5
B.1.1.	<i>HW–AECM Series Specifications</i>	5
B.2.	COIL DATA	6
B.2.1.	<i>2-Pipe Systems</i>	6
B.5.	VALVE INFORMATION	11
B.5.2.	<i>3-Way 1/2" Valve Body</i>	11
C.	SERVICE AND INSTALLATION	12
C.1.	INSTALLATION OF HIGH-WALL UNIT	12
C.1.1.	<i>Selecting a Location</i>	12
C.1.2.	<i>Mounting Plate Dimensions</i>	13
C.1.3.	<i>Installing the Mounting Plate</i>	14
C.1.4.	<i>Drilling the Condensate Drainage Hole</i>	14
C.1.5.	<i>Installing the Hydronic Unit</i>	15
C.1.6.	<i>Drainage Piping Works</i>	15
C.2.	UNIT MAINTENANCE AND PREPARATION	16
C.2.1.	<i>Opening and Closing Of Lift-Up Grille Cover</i>	16
C.2.2.	<i>Removing Front Cover Assembly</i>	16
C.2.3.	<i>Air Purging</i>	17
C.2.4.	<i>Wiring Connections</i>	17
C.3.	PIPE CONNECTIONS WITH VALVE	18
D.	CONTROL SPECIFICATIONS: COMPLETE CONTROL PCB - S TYPE CONTROL	19
D.1.	DEFINITION OF INPUT/OUTPUT	19
D.2.	WIRING DIAGRAM FULL CONTROL PCB – S CONTROL TYPE	20
D.3.	CONFIGURATION SETTINGS	21
D.4.	CONTROL LOGICS FOR 2-PIPE SYSTEM	23
D.4.1.	<i>With Thermoelectric Valve Configuration</i>	23
D.4.2.	<i>Without Thermoelectric Valve Configuration</i>	26
D.5.	CONTROL LOGICS FOR 4-PIPE SYSTEM	28
D.6.	SLEEP MODE	30
D.7.	AUTO FAN SPEED	30
D.8.	LOUVER	31
D.9.	BUZZER	31
D.10.	AUTO RESTART	31
D.11.	OPERATION OF CONTROL PANEL ON HIGH-WALL UNIT	31
D.11.1.	<i>On/Off Switch</i>	31
D.11.2.	<i>Electric Heater Safety Switch (on control PCB)</i>	31
D.13.	LED DISPLAY AND ERROR DESCRIPTION	33
D.14.	LED DISPLAY ON MASTER/SLAVE CONNECTION	34
E.	NETWORKING SYSTEM	35
E.1.	MASTER – SLAVE NETWORK	35
E.1.1.	<i>Master – Slave Network Setup</i>	36
E.1.2.	<i>Master-Slave Communication Method</i>	39
E.2.	UNIT NETWORK WIRING SCHEME	40
E.3.	OPEN MODBUS PROTOCOL	41
F.	CONTROL SPECIFICATIONS: FLEXIBLE CONTROL PCB - W TYPE CONTROL	45
F.1.	DEFINITION OF INPUT/OUTPUT	45
F.2.	WIRING DIAGRAM FLEXIBLE CONTROL PCB - W CONTROL TYPE	46
F.3.	ONBOARD CONFIGURATION	47
F.4.	CONTROL LOGICS	48
F.5.	LED DISPLAY	48
F.6.	ERROR DESCRIPTION	48

- G. USERS INTERFACE49**
- G.1. REMOTE CONTROL HANDSET.....49
- G.2. WIRED WALL PAD.....50
 - G.2.1. *Wall Pad Display*50
 - G.2.2. *Wall Pad Operation Guidelines*51
 - G.2.3. *EC unit RPM setting*54
- H. SENSOR RESISTANCE R-T CONVERSION TABLE55**
- I. TROUBLESHOOTING GUIDE57**

A. General Description

This High-Wall Unit is designed to meet and exceed demanding requirements for efficiency, quiet operation and appearance. The sleek profile and elegantly styled cabinet complements any interior design theme, while the microprocessor assures accurate environmental control.

Cabinet ~ the stylish cabinet is constructed of durable flame resistant acrylonitrile-butadiene-styrene (ABS) plastic. The silver white color and rounded corners provide its modern look.

Water Coil ~ the water coil has a large heat transfer surface and utilizes the latest fin profile technology. It combines an advanced technology approach with the security of a traditional design regarding tube thickness. The water coil is also equipped with an air vent valve and a water purge valve.

Integral Hoses ~ an integral hose is a synthetic elastomer tube, with stainless steel outer braiding and brass connectors, which enables quick, low cost connections with no brazing.

Blower and Motor ~ the unit incorporates only specially designed and tested EC motors, allowing the blower wheel to provide optimum performance in airflow-efficiency and quiet operation.

Filters ~ washable, easy-to-remove, fine mesh air filters are standard to all high-wall models. Tabs located on the front of the unit can be unsnapped, allowing the filter to be easily slid downward and removed. No tools are required, nor any dismantling of the equipment.

Air Grille Distribution ~ all units are equipped with both deflector blades and independent directional vanes, enabling supply air to be automatically distributed, and air flow and direction to be customized.

Microprocessor Control ~ see **Controls Specifications** for complete control specifications and details. The main design features include:

- ~ FCEER rating class: A/B.
- ~ FCCOP rating class: B/C.
- ~ High efficiency EC motor with PID algorithmic processing in auto-mode.
- ~ 2-pipe, 2-pipe with booster electric heat, 2-pipe with primary electric heat, 4-pipe with 4x2 device installed.
- ~ Cool, Heat, Auto, Dehumidifier and Fan modes.
- ~ Sleep, Auto-Fan, Daily Timer, Auto-Restart with memory functions.
- ~ User friendly remote control handset.
- ~ Heat and cool temperature protections and safety cut out.
- ~ 2-way and 3-way on/off valve control.
- ~ Addressable control and error diagnostics (Master-Slave) for sub-networks of up to 32 units, with IR handset as global control interface.
- ~ Wired wall pad controller (optional) with 7-day programmable timer, real-time clock, network control (global and addressable) and error diagnostics.
- ~ Manual control panel in cabinet.
- ~ Auxiliary switch for cooling and heating signal.
- ~ Occupancy (remote on/off) contacts / economy mode contacts.
- ~ Open Modbus communication protocol.
- ~ Local PC host control solution (optional).

B. Technical Data

B.1. General Specification

B.1.1. HW-AECM Series Specifications

Product range: HW-AECM Hydronic High Wall 2 pipe with EC Motor (American Standard)

		HW-[Size]-V~AECM		04	06	12	15	18	20	24	30	
Unit Configuration	Configuration		2-pipe									
	Number Of Fan Blowers		Single									
	Power Supply	(V/Ph/Hz)	220 or 115/1/60									
	Operation Control		~S: Complete function onboard PCB with integrated group control functionality. ~W: Flexible function onboard PCB with drain pump, louver and zone control functionality.									
Performance Data	Air	Air Flow	H	CFM	218	294	294	379	464	576	635	729
			M		171	218	218	294	435	447	576	635
			L		129	171	171	218	335	353	353	447
	Cooling	Cooling Capacity	H	BTU/Hr	4158	6967	8394	10207	12602	16293	18174	20249
			M		3497	5534	6277	8394	11069	13254	16293	17493
			L		2833	4620	5486	6339	9040	11393	11393	13254
		Sensible Cooling Capacity	H		2936	4889	5822	7126	8808	11171	12499	13969
			M		2458	3856	4313	5822	7702	9034	11171	12018
			L		1979	3202	3754	4357	6247	7734	7734	9034
	Heating	Heating Capacity	H	BTU/Hr	6653	11147	13430	16331	20163	26069	29078	32398
			M		5595	8854	10043	13430	17710	21206	26069	27989
			L		4533	7392	8778	10142	14464	18229	18229	21206
		Max. Electric Heater Capacity@115V			1700				2500			
	Max. Electric Heater Capacity@220V		3400				5100					
	Electrical	Fan motor power	H	W	13	18	18	26	30	30	40	50
			M		10	13	13	20	20	20	30	40
			L		6	10	10	13	13	15	19	25
	Fan Motor Running Current @ H 115V		A	0.16	0.284	0.284	0.364	0.544	0.696	1.04	1.5	
	Fan Motor Running Current @ H 220V		A	0.08	0.142	0.142	0.182	0.272	0.348	0.52	0.75	
	Soun	Sound PressureLevel		dB(A)	31/26/24	39/31/26	40/33/28	45/34/31	49/44/37	43/39/36	47/43/37	50/47/40
Sound Power Level		40/35/33	48/40/35		49/42/37	54/43/40	58/53/46	52/48/45	56/52/46	59/56/49		
Hydraulic	Cooling Water Flow Rate	H	GPM	0.83	1.39	1.68	2.03	2.52	3.25	3.63	4.04	
		M		0.70	1.10	1.25	1.68	2.20	2.65	3.25	3.49	
		L		0.56	0.92	1.09	1.26	1.81	2.27	2.27	2.65	
	Cooling Pressure Drop	H	Ft.wg	6.18	7.53	6.37	8.92	6.12	11.92	14.33	17.33	
		M		4.61	5.09	3.88	6.37	4.91	8.33	11.92	13.42	
		L		3.23	3.75	3.09	3.95	3.48	6.47	6.47	8.33	
	Heating Water Flow Rate @H/M/L		GPM		Same as "Cooling Water Flow Rate"							
	Heating Pressure Drop	H	Ft.wg	4.95	6.03	5.09	7.13	4.89	9.53	11.47	13.87	
M		3.69		4.07	3.11	5.09	3.93	6.67	9.53	10.73		
L		2.58		3.00	2.47	3.16	2.79	5.17	5.17	6.67		
Water Content		gal		0.01	0.02	0.03	0.03	0.05	0.07	0.07	0.07	
Construction and Package Data	Water Connections		Type	Socket (NPT Threaded Female)								
	In		in	1/2"								
	Out			0.63								
	Condensate Drainage Connection				0.63							
	Dimensions	L	in	34.45				41.34				
		W		8.66				9.25				
H		11.81				12.2						
Net Weight		lbs		24.3	26.5	28.7	28.7	30.9	35.3	35.3	35.3	

a. Cooling mode (2-pipe):

b. Heating mode (2-pipe):

- Return air temperature: 80.0F DB/ 67.0F WB.
- Inlet/ outlet water temperature: 45F/55F.

- Return air temperature: 70F.
- Inlet water temperature: 140F.
- Water flow-rate: same as cooling mode.

B.2. Coil Data

B.2.1. 2-Pipe Systems

Model	Fin Height (inch)	Fin Length (inch)	Fins per Inch	No. of Rows	No. of Copper	No. of Circuits	Tube Diameter (inch)
HW-04	9.1	26.8	19.5	2	8	2	0.3
HW-06	14.1	26.8		2	20	4	0.3
HW-12	14.1	26.8		2	26	5	0.3
HW-15	14.1	26.8		2	26	5	0.3
HW-18	14.1	26.8		2	34	5	0.3
HW-20	14.9	33.3		2	36	6	0.3
HW-24	14.9	33.3		2	36	6	0.3
HW-30	14.9	33.3		2	36	6	0.3

B.3. Sound Power and Pressure data

Sound Power

A-weighted Sound Power dB(A)		31.0	29.2	27.8	43.1	33.9	29.9	43.1	33.9	29.9	50.1	37.1	33.6
Sound Power in 1/3 Octave-bands (unit dB)	31.5Hz	4.6	10.4	11.5	2.3	0.9	4.1	11.5	0.9	4.1	10.3	5.4	8.9
	63Hz	3.1	3.5	4.9	0.8	5.5	3.4	10.0	5.5	3.4	13.0	3.8	2.3
	125Hz	6.2	7.5	6.2	7.8	8.4	5.5	17.0	8.4	5.5	22.2	11.7	8.7
	250Hz	17.5	13.5	10.1	21.1	22.5	17.8	30.3	22.5	17.8	38.3	25.3	23.7
	500Hz	23.0	17.8	13.0	25.9	26.6	21.2	35.1	26.6	21.2	41.7	30.5	26.1
	1000Hz	19.8	15.2	12.8	23.1	21.1	16.3	32.3	21.1	16.3	40.2	26.4	20.9
	2000Hz	16.0	15.2	14.8	16.8	16.9	15.1	26.1	16.9	15.1	35.8	20.4	17.0
	4000Hz	15.4	15.6	15.4	9.1	15.8	15.3	18.3	15.8	15.3	26.1	16.4	15.9
	8000Hz	14.6	14.6	14.3	5.5	14.9	14.4	14.8	14.9	14.4	17.1	14.9	14.7
	16000Hz	7.4	8.6	7.8	-1.2	7.8	7.9	8.0	7.8	7.9	7.9	7.9	8.0
	Speed	H	M	L	H	M	L	H	M	L	H	M	L
Model		HW-04			HW-06			HW-12			HW-15		

A-weighted Sound Power dB(A)		53.7	48.6	41.3	46.8	43.4	40.1	49.8	46.8	40.1	55.7	52.1	43.4
Sound Power in 1/3 Octave-bands (unit dB)	31.5Hz	3.6	3.9	11.5	16.8	8.3	12.3	12.8	16.8	12.3	17.1	9.4	8.3
	63Hz	22.3	14.5	11.1	17.2	11.2	11.8	12.3	17.2	11.8	22.4	18.0	11.2
	125Hz	27.2	20.4	15.0	21.2	18.5	14.9	23.0	21.2	14.9	26.0	25.2	18.5
	250Hz	42.3	36.1	29.5	32.8	29.7	25.5	35.0	32.8	25.5	40.6	38.1	29.7
	500Hz	45.8	40.3	35.1	38.4	36.5	33.0	41.5	38.4	33.0	47.0	44.6	36.5
	1000Hz	43.9	38.5	31.4	36.2	32.9	29.3	39.9	36.2	29.3	46.3	42.1	32.9
	2000Hz	40.7	33.8	24.4	29.4	25.4	26.7	33.7	29.4	26.7	40.9	36.6	25.4
	4000Hz	31.7	24.5	17.9	21.3	18.8	32.2	24.6	21.3	32.2	33.8	28.3	18.8
	8000Hz	20.4	16.1	15.0	15.5	15.8	33.0	16.9	15.5	33.0	21.2	18.6	15.8
	16000Hz	8.2	10.7	7.8	6.9	6.9	27.1	10.9	6.9	27.1	8.2	7.0	6.9
	Speed	H	M	L	H	M	L	H	M	L	H	M	L
Model		HW-18			HW-20			HW-24			HW-30		

Sound Pressure

A-weighted Sound Pressure dB(A)		21.8	20	18.6	33.8	24.6	20.7	33.8	24.6	20.7	40.9	27.9	24.3
Sound Pressure in 1/3 Octave-bands (unit: dB)	31.5Hz	-4.7	1.2	2.2	11.5	-8.4	-5.1	2.3	-8.4	-5.1	1.1	-4.6	-3.8
	63Hz	-6.1	-5.7	-4.3	10.0	-3.8	-5.9	0.8	-3.8	-5.9	3.8	-6.2	-5.4
	125Hz	-3.0	-1.7	-3.1	17.0	-0.8	-3.8	7.8	-0.8	-3.8	12.9	1.7	2.5
	250Hz	8.2	4.3	0.9	30.3	13.2	8.6	21.1	13.2	8.6	29.0	15.3	16.1
	500Hz	13.8	8.6	3.8	35.1	17.3	11.9	25.9	17.3	11.9	32.4	20.5	21.3
	1000Hz	10.6	5.9	3.5	32.3	11.9	7.1	23.1	11.9	7.1	31.0	16.4	17.2
	2000Hz	6.8	6.0	5.6	26.1	7.7	5.9	16.8	7.7	5.9	26.6	10.3	11.1
	4000Hz	6.2	6.4	6.2	18.3	6.6	6.1	9.1	6.6	6.1	16.9	6.3	7.1
	8000Hz	5.4	5.4	5.1	14.8	5.7	5.1	5.5	5.7	5.1	7.8	4.9	5.7
	16000Hz	-1.9	-0.6	-1.5	8.0	-1.4	-1.3	-1.2	-1.4	-1.3	-1.3	-2.2	-1.4
Speed	H	M	L	H	M	L	H	M	L	H	M	L	
Model		HW-04			HW-06			HW-12			HW-15		

A-weighted Sound Pressure dB(A)		44.4	39.4	32	37.5	34.2	30.9	40.5	37.5	30.9	46.5	42.9	34.2
Sound Pressure in 1/3 Octave-bands (unit: dB)	31.5Hz	-5.7	-5.3	2.2	7.6	-0.9	3.1	3.6	7.6	3.1	7.9	0.1	-0.9
	63Hz	13.1	5.3	1.9	7.9	2.0	2.5	3.1	7.9	2.5	13.2	8.8	2.0
	125Hz	17.9	11.2	5.8	12.0	9.3	5.7	13.7	12.0	5.7	16.8	16.0	9.3
	250Hz	33.1	26.9	20.3	23.6	20.5	16.3	25.8	23.6	16.3	31.3	28.8	20.5
	500Hz	36.6	31.1	25.9	29.1	27.3	23.8	32.3	29.1	23.8	37.7	35.4	27.3
	1000Hz	34.7	29.3	22.2	27.0	23.7	20.1	30.7	27.0	20.1	37.1	32.9	23.7
	2000Hz	31.5	24.6	15.2	20.2	16.2	17.4	24.5	20.2	17.4	31.6	27.4	16.2
	4000Hz	22.5	15.3	8.7	12.1	9.6	23.0	15.4	12.1	23.0	24.5	19.1	9.6
	8000Hz	11.2	6.9	5.7	6.3	6.5	23.8	7.7	6.3	23.8	12.0	9.3	6.5
	16000Hz	-1.1	1.5	-1.4	-2.3	-2.4	17.9	1.7	-2.3	17.9	-1.0	-2.2	-2.4
Speed	H	M	L	H	M	L	H	M	L	H	M	L	
Model		HW-18			HW-20			HW-24			HW-30		

B.4. Dimensional Drawings

Dimensional drawing for HW-04/06/12/15/18-AECM

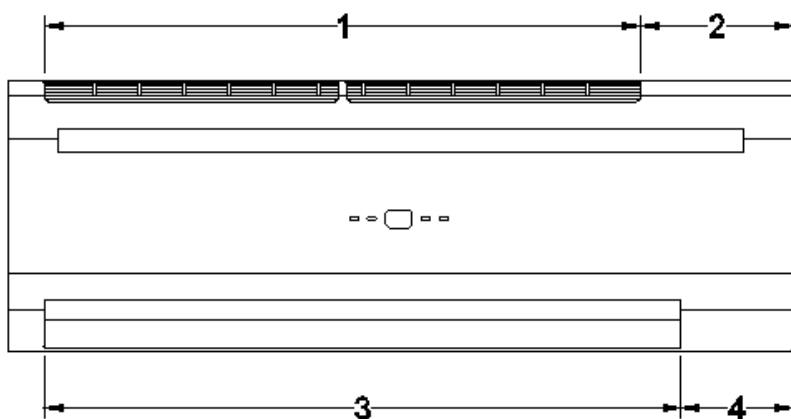
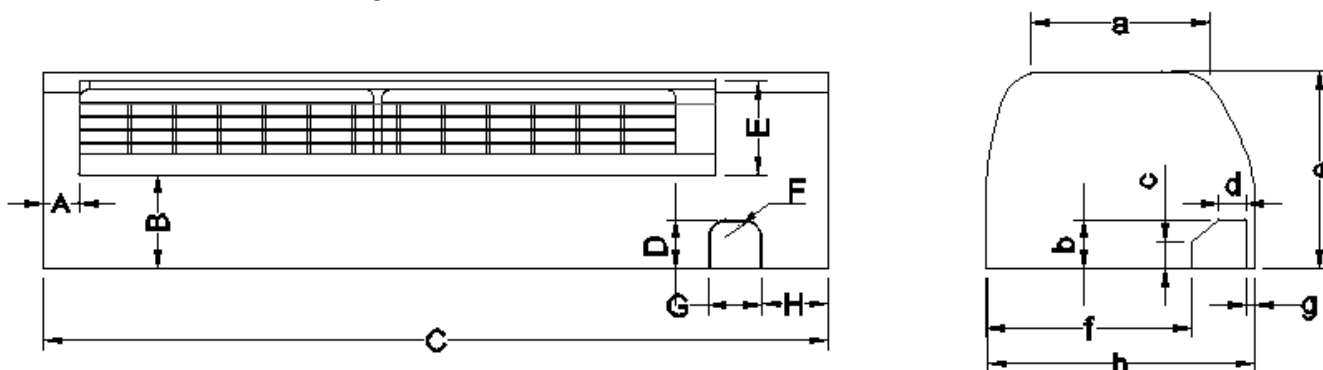

Model	Unit Dimensions							
	A	B	C	D	E	F	G	H
HW-04/06/12/15/18	1.57	4.13	34.45	2.17	4.13	R0.78	2.36	2.91

Model	Unit Dimensions							
	a	b	c	d	e	f	g	h
HW-04/06/12/15/18	7.87	2.17	1.18	1.18	8.66	9.02	0.39	11.81

Model	Unit Dimensions			
	1	2	3	4
HW-04/06/12/15/18	26.18	6.69	27.95	4.92

(All dimensions shown in inch)

Dimensional drawing for HW-20/24/30-AECM

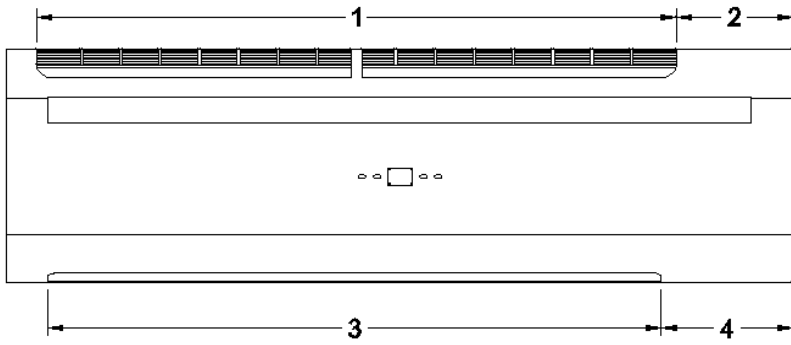
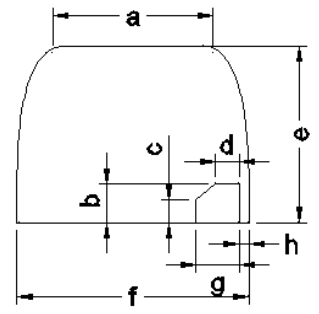
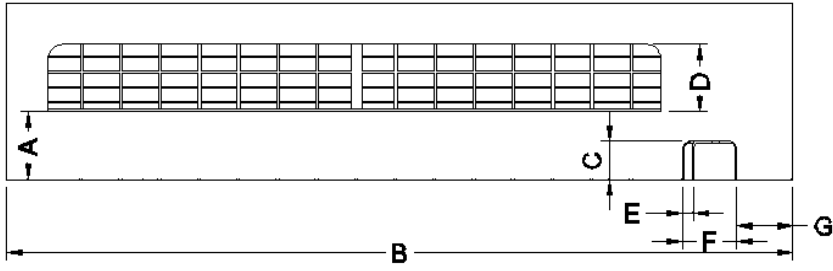

Model	Unit Dimensions						
	A	B	C	D	E	F	G
HW-20/24/30	3.54	41.34	2.01	3.54	0.59	2.87	2.91

Model	Unit Dimensions			
	1	2	3	4
HW-20/24/30	33.66	6.10	32.28	6.89

Model	Unit Dimensions							
	a	b	c	d	e	f	g	h
HW-20/24/30	8.46	2.05	1.18	1.26	9.25	12.20	2.28	0.51

(All dimensions shown in inch)

B.5. Valve Information

B.5.1. 2-Way 1/2" Valve Body

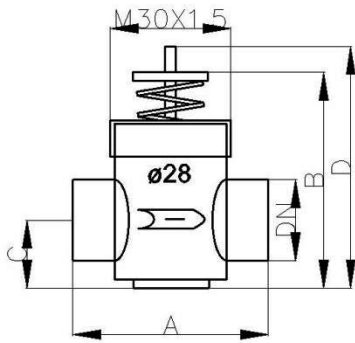

Valve Model	Valve Dimensions (inch)				
	DN	A	B	C	D
SGS14HFCA-23020201	D15 (G1/2")	2.05	1.85	0.77	2.48

B.5.2. 3-Way 1/2" Valve Body

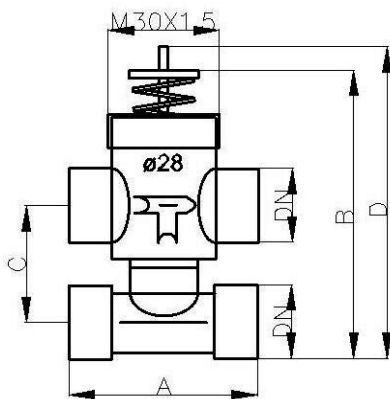

Valve Model	Valve Dimensions (inch)				
	DN	A	B	C	D
SGS14HFCA-23020202	D15 (G1/2")	2.05	2.76	1.57	3.39

Differential Pressure Chart

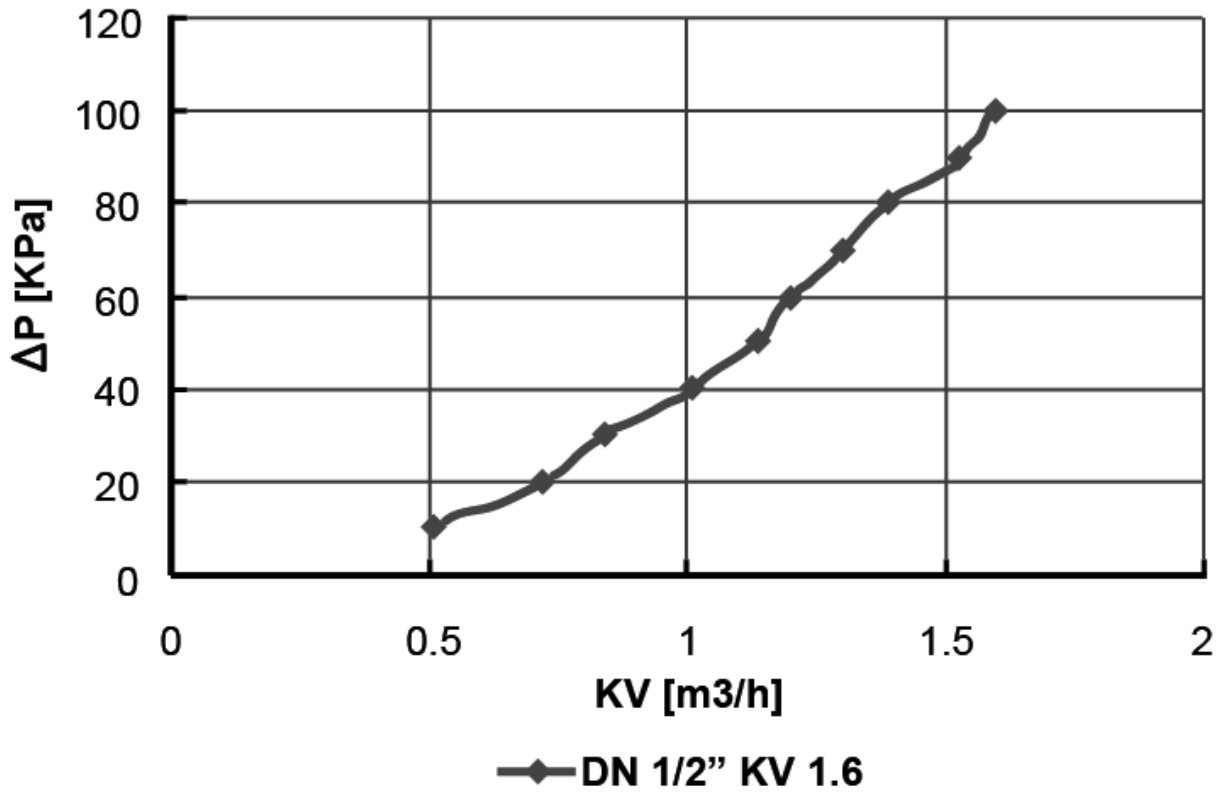

C. Service and Installation

Operating Limits

Power supplies

Volt	Phase	Hz	Model
208~240	1	60	HW-VX-AECM
110~120	1	60	HW-VY-AECM

Water circuit

Minimum entering water temperature	+2°C (35.6°F)
Maximum entering water temperature	+80°C (176°F)
Water side recommended maximum pressure	1600 kPa (232 PSI)

C.1. Installation of High-Wall Unit

C.1.1. Selecting a Location

Select the location for the high-wall unit with the following considerations in mind:

1. The front of the air inlet and outlet should be clear of any obstructions. The air should flow freely.
2. The wall where the unit is to be mounted should be solid enough not to resonate and produce noise.
3. The location should allow easy access to install the connecting water pipes, and be where drainage can be easily achieved.
4. Ensure the clearance around the fan coil unit conforms to the following drawing.
5. From the floor the height of the unit should be above eye level.
6. Avoid installing the unit in direct sunlight.

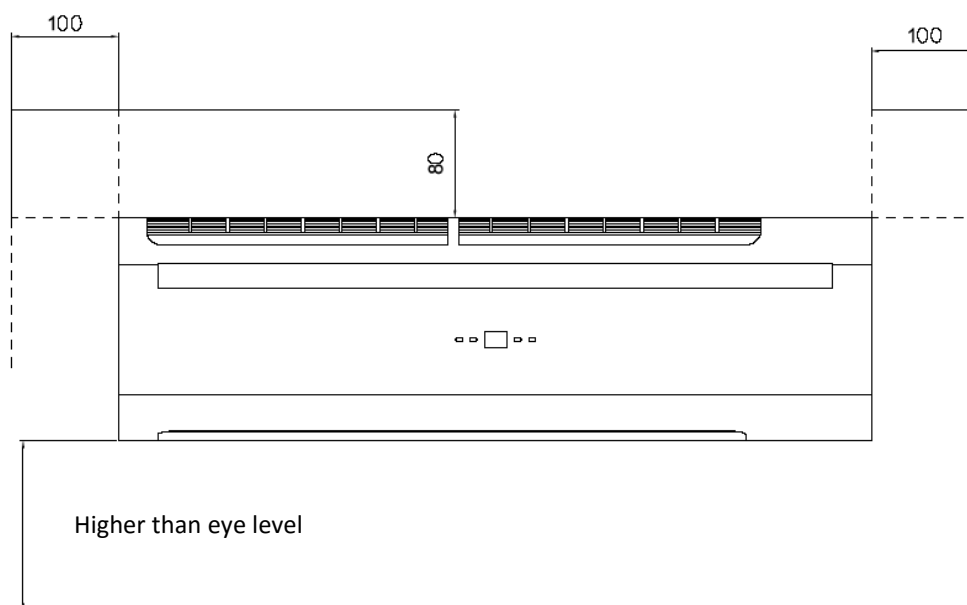

* Required clearance for maintenance and servicing is as shown above.

** All dimensions shown in mm.

7. The signal receiver on the unit must be kept away from any high frequency emission source.
8. Keep the unit away from fluorescent lamps, which may affect the control system.
9. To avoid electromagnetic control system interference, ensure control wires are installed separately from 110-240 VAC power supply wires.
10. Where electromagnetic waves are present, use shielded sensor cables.
11. Install a noise filter if the power supply creates any disruptive noises.

C.1.2. Mounting Plate Dimensions

HW-04/06/12/15/18 –AECM

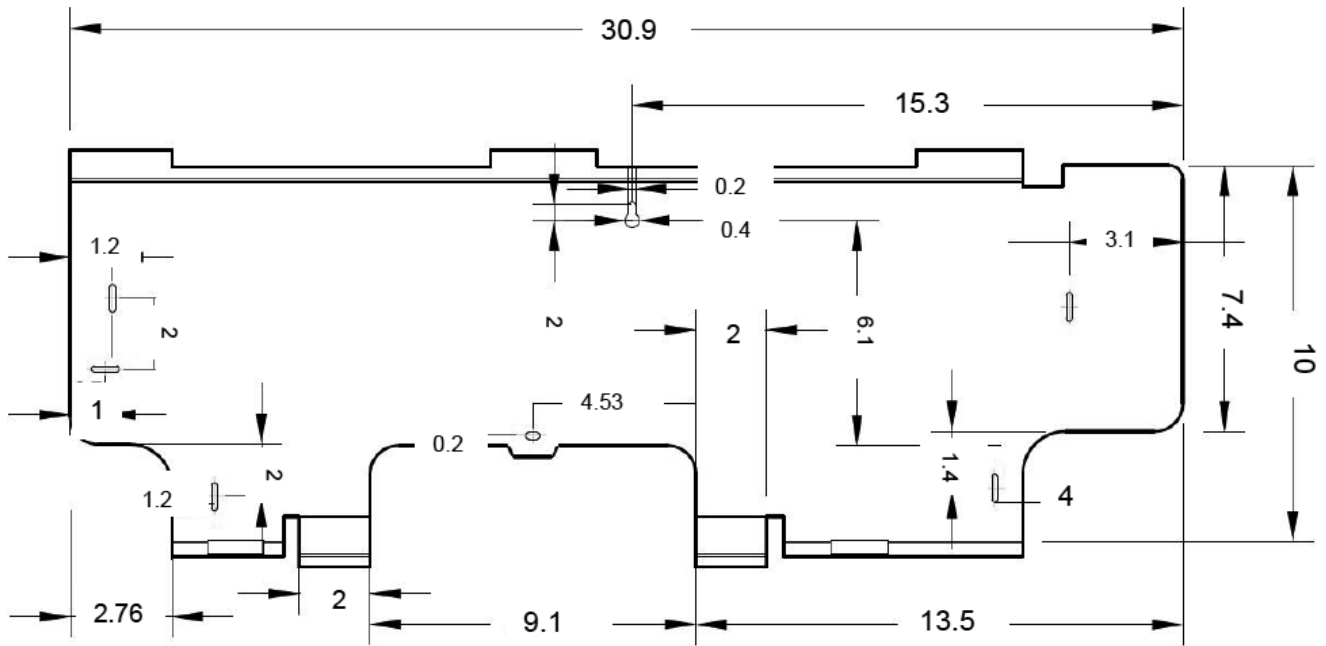

HW-20/24/30 –AECM

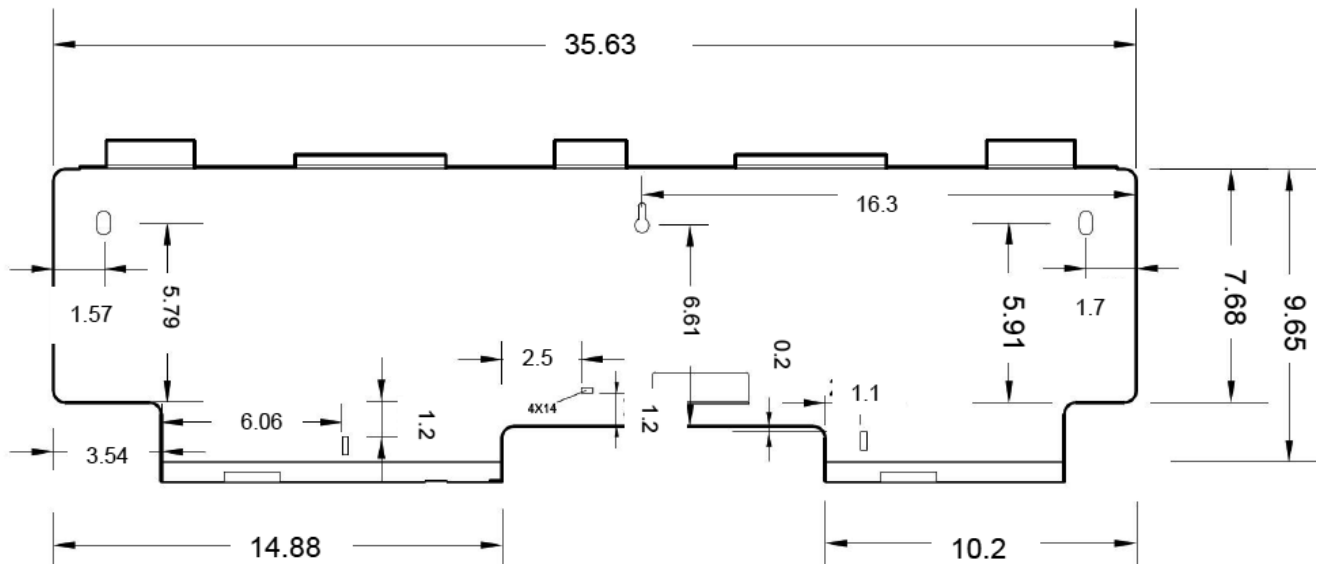

(All dimensions shown in inch)

C.1.3. Installing the Mounting Plate

1. Select the structural position (e.g. a pillar or lintel) on the wall.
2. Then temporarily fasten the mounting plate on the wall with a steel nail.

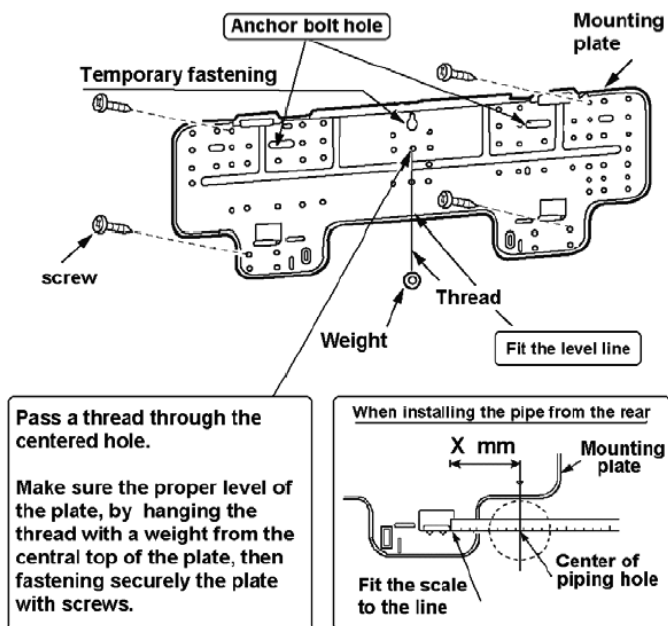

3. Mount the mounting plate horizontally as shown in the above figure or by means of gradiometer. Failure to follow this may cause water to drip indoors and create atypical noise.
4. Fix the mounting plate by means of expansion screws or tapping screws.

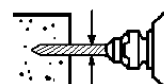

Drill a hole on the wall

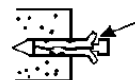

Anchor plastic clip



Expansion screw

C.1.4. Drilling the Condensate Drainage Hole

1. Ensure that the hole for condensate drainage is correctly positioned. The height should be lower than the bottom edge of the indoor unit.
2. Drill a 65mm diameter hole with a descending slope.
3. Seal it off with putty after installation.

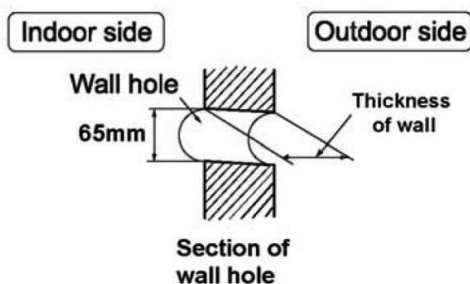

C.1.5. Installing the Hydronic Unit

1. Pass the piping through the hole in the wall and hook the indoor unit on the mounting plate by the upper hooks.
2. Move the body of the unit from side to side to verify if it is securely fixed.
3. While pushing the unit toward the wall, lift it slightly from beneath to hook it up on the mounting plate by the lower hooks.
4. Make sure the unit firmly rests on the hooks of the mounting plate.

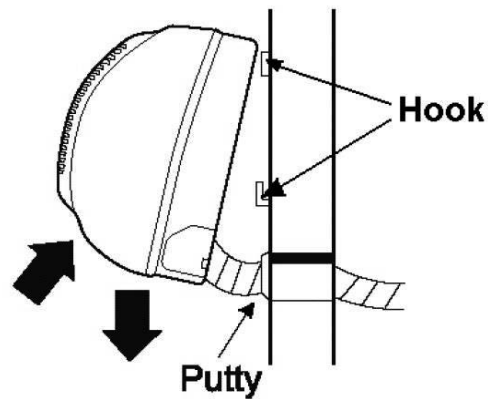

C.1.6. Drainage Piping Works

1. Install the drain hose so that it slopes downward slightly for free drainage. Avoid installing it as shown in the below illustrations marked with an "X".

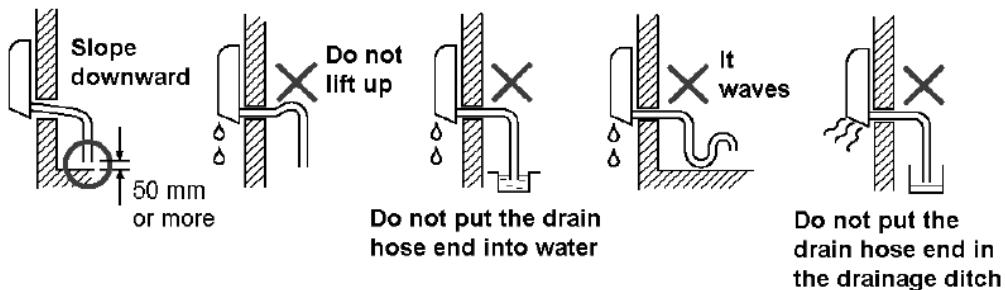

2. Put water in the drain pan and make sure that the water drains outdoors.
3. If the flexible drain hose provided with the indoor unit is not long enough, please extend it by joining it to an extension hose (not provided). Be sure to insulate the connecting part of the extension drain hose with a shield pipe as shown.

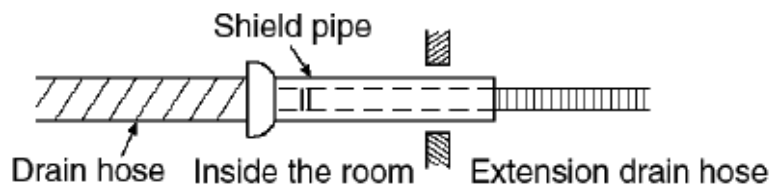

4. If the attached drain hose passes through an indoor area, insulate it with heat insulation material.

C.2. Unit Maintenance and Preparation

C.2.1. Opening and Closing Of Lift-Up Grille Cover

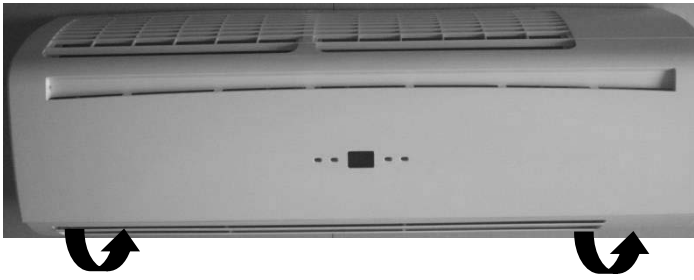

Open the grille cover by lifting from the bottom position indicated by the arrows.



Close the grille cover by pressing down at the positions indicated by the arrows.

C.2.2. Removing Front Cover Assembly

1. Set the horizontal louver to the horizontal position.
2. Remove the screw caps below the louver, and then remove the mounting screws.
3. Open the lift-up grille cover by grasping the panel at both sides as shown above.
4. Remove the remaining screws located in the center of the front cover.
5. Grasp the lower part of the front cover and pull the entire assembly out and up towards you.

SWC

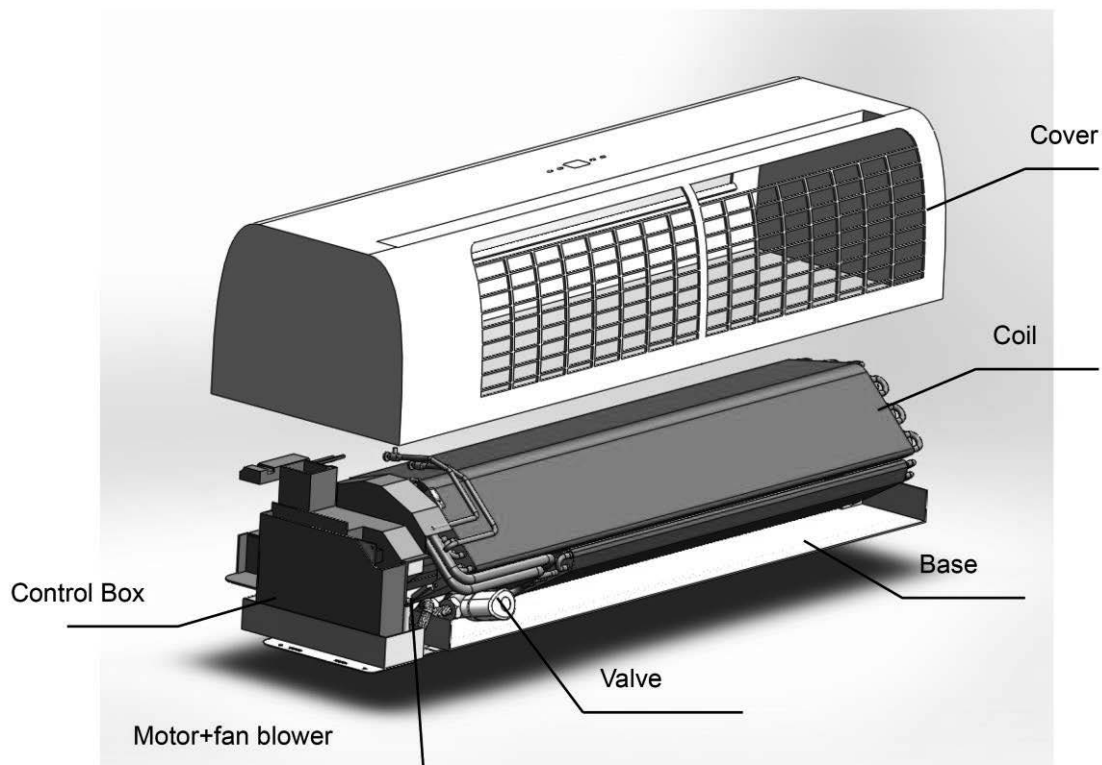

C.2.3. Air Purging

1. After connecting the water inlet and outlet pipes to the main supply lines turn on the main breaker and operate the unit in COOLING mode.
2. Open the water inlet valve and flood the coil.
3. Check all connections for water leakage. If no leak is found, open the purging valve with an open end wrench while supporting the unit with your other hand. Then purge the air trapped inside the coil. When performing this activity, take care not to touch the electrical parts.
4. Close the purging valve when no bubbles appear.
5. Open the water outlet valve.

C.2.4. Wiring Connections

Unit components are wired to the terminal block of the indoor unit. Wiring can be accessed from the terminal block inside the control box.

C.3. Pipe Connections with Valve

Pre-assembly

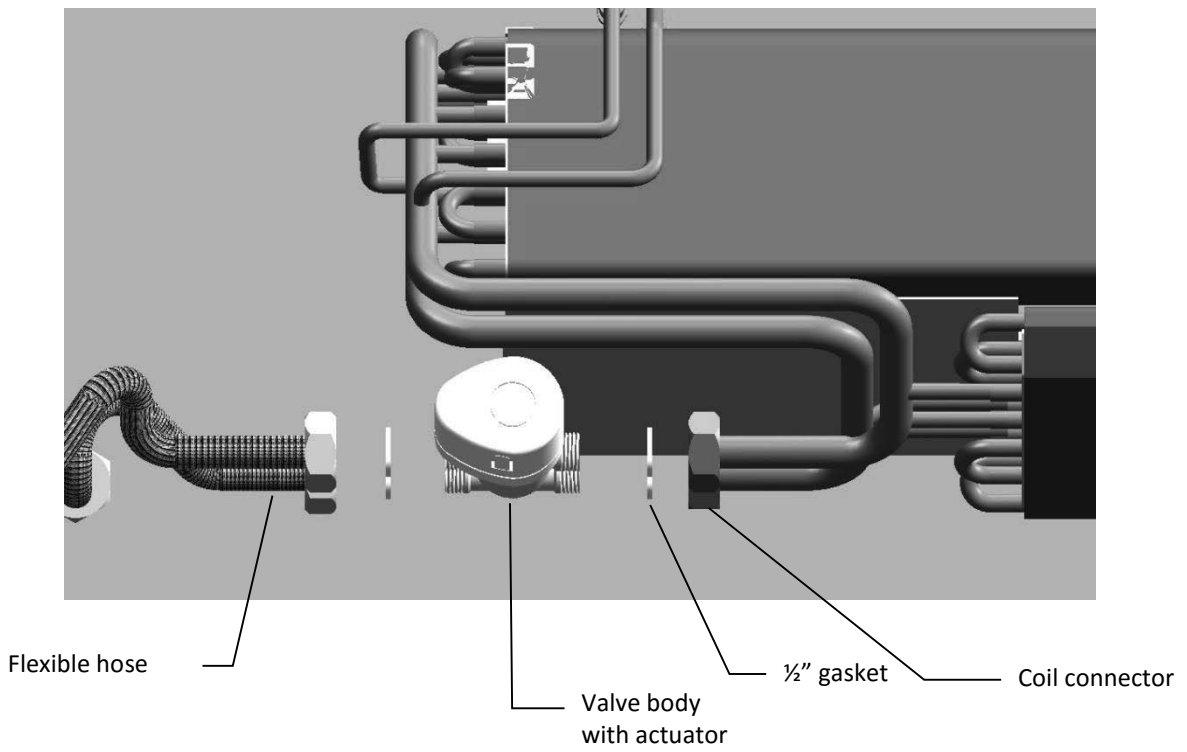

Complete Assembly

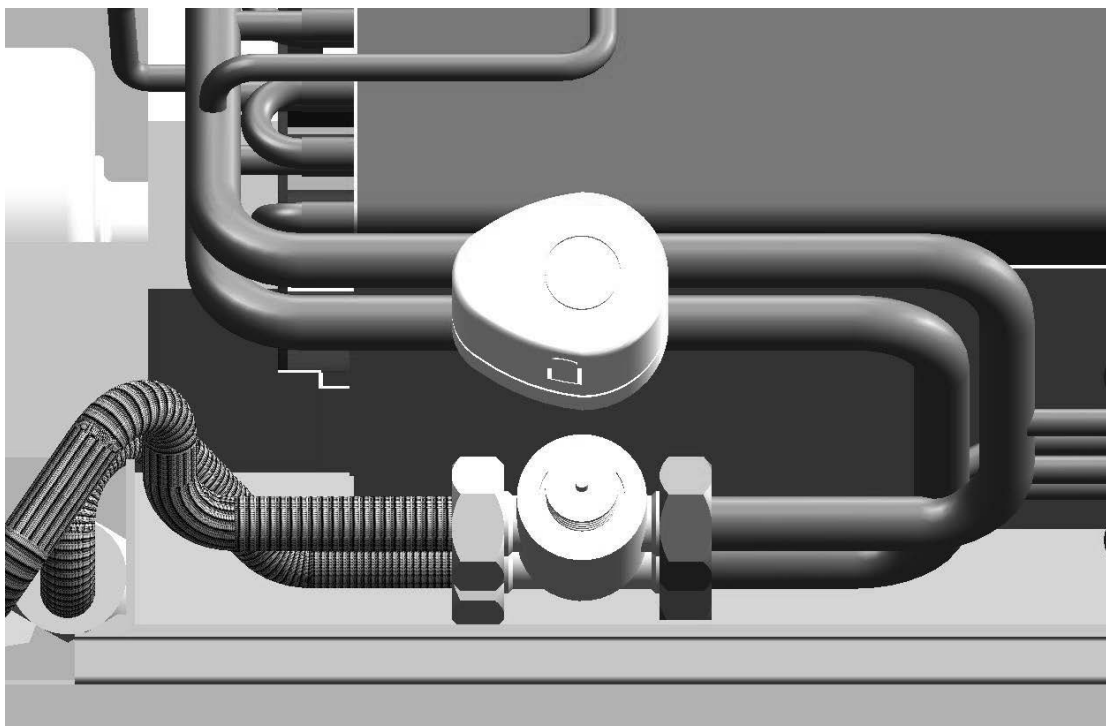

D. Control Specifications: Complete Control PCB - S Type Control

Used in all High-Wall [V/P] ~S unit configurations.

Abbreviations

Ts =	Setting temperature	AUX1 =	Hot water free contact
Tr =	Room air temperature	AUX2 =	Chilled water free contact
Ti1 =	Chilled water coil temperature	MTV1 =	Chilled Motorized valve
Ti2 =	Hot water coil temperature	MTV2 =	Hot Motorized valve

D.1. Definition of Input/Output

I/O		Code	2-Pipe	4-Pipe
Analogue Input	Return air sensor	AI1	Return air temperature (Tr)	
	2-pipe coil circuit sensor	AI2	Chilled / hot water coil circuit (Ti1)	Chilled water coil circuit (Ti1)
	Hot water sensor	AI3	N/A	Hot water coil circuit (Ti2)
Input	LED display / IR receiver	X-DIS1	Digital communication port to LED display / IR receiver board.	
	Wired wall pad	TTL1	Digital communication port to wired wall pad board.	
Digital input	Occupancy contact	On/Off	Window contacts: for remote ON/OFF (when DIPB SW1 = 1). Economy contacts: for remote activation of economy mode (when DIPB SW1 = 0).	
	Electrical heater safety switch	EH	Voltage-free (NC). The contact is closed before the EH is turned on.	
Power input	Phase	L1	Power supply: 220V/1Ph/60Hz 115V/1Ph/60Hz	
	Neutral	N1		
	Earth	PE1		
Voltage output	Fan	CN4	Fan driver	
	Valve 1	MTV1	2-pipe coil circuit valve output – chilled / hot water valve. Voltage output (L)	2-pipe coil circuit valve output – chilled water valve. Voltage output (L)
	Valve 2	MTV2	Reserved	4-pipe coil circuit valve output – hot water valve. Voltage output (L)
	Voltage of electrical heater (Live)	HEAT	Voltage output (L), maximum 25 A	
Output	Stepping motor	CN1 / CN2	Louver stepping motor relay	
	Auxiliary contact 2	AUX2	Cooling mode signal relay (NO). Voltage free contact. To ensure the sensitivity of the connection, please make sure max wiring length < 100ft	
	Auxiliary contact 1	AUX1	Heating mode signal switch (NO). Voltage free contact. To ensure the sensitivity of the connection, please make sure max wiring length < 200" 100ft	
	Serial BUS port	CN3	Master-slave network serial connection OR MODBUS / local PC host network serial connection.	

D.2. Wiring Diagram Full Control PCB – S Control Type

Unit wiring scheme

ABG-S1.1

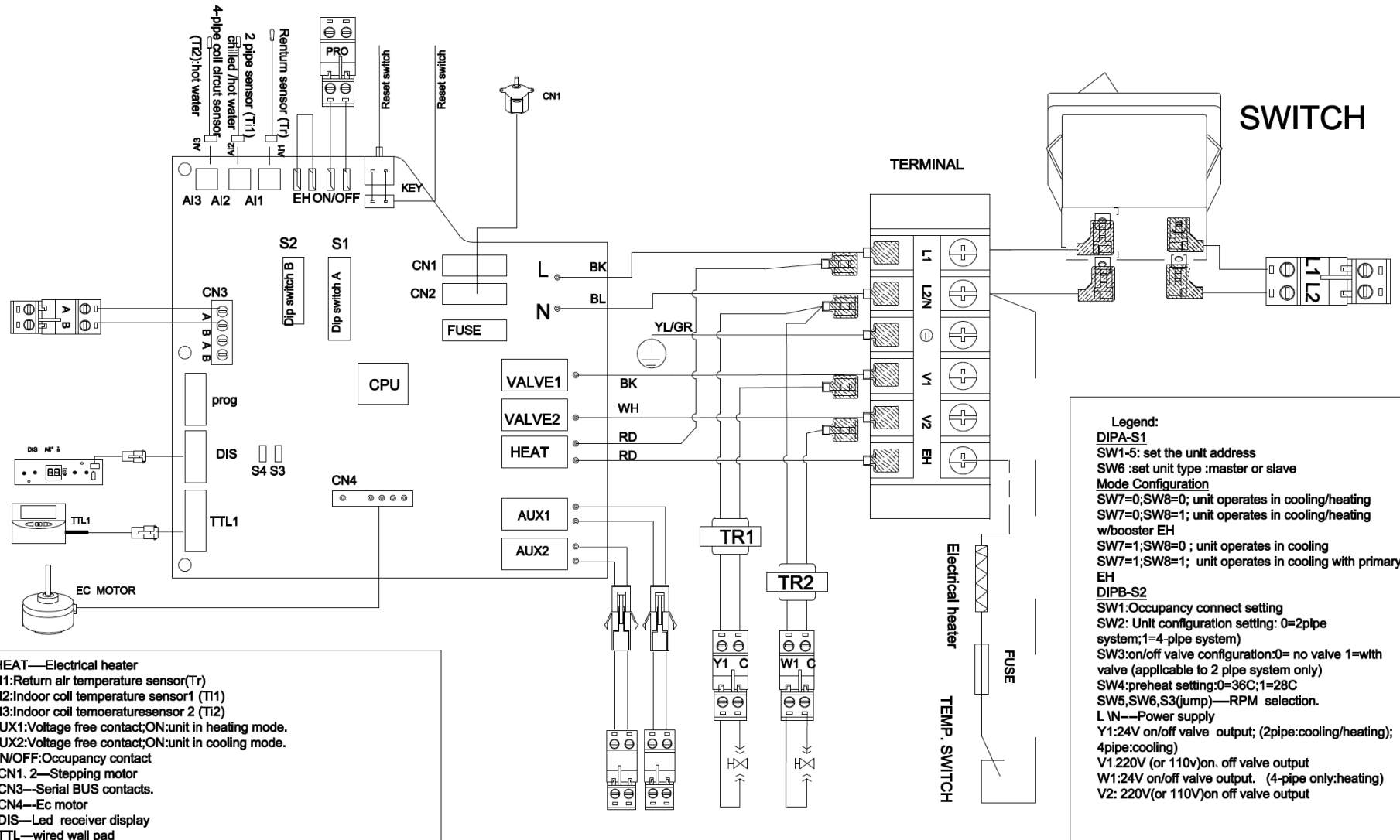

D.3. Configuration Settings

There are 2 DIP switches set on the PCB:

1. DIPA-S1 (8 positions)
 - SW1 – SW6: used for master-slave / BMS network address.
 - SW7 – SW8: used for operating mode configuration.
2. DIPB-S2 (6 positions)
 - SW1: Occupancy / economy mode selection.
 - SW2: 2-pipe / 4-pipe configuration selection.
 - SW3: Thermoelectric valve configuration selection (2-pipe system only).
 - SW4: Pre-heat protection temperature selection.
 - SW5 – SW6: brushless DC fan motor configuration.

Default DIP Switch Settings:

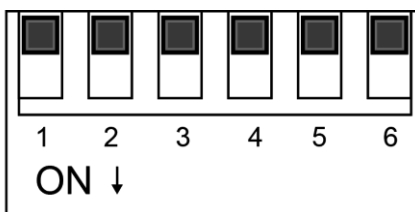
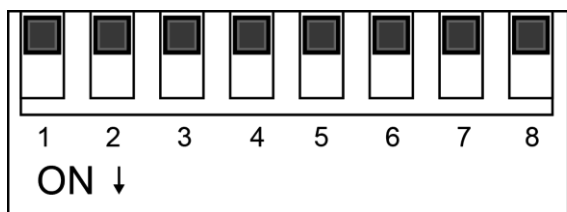

Unit Configuration
WITHOUT Valve

Figure 1

DIPA –S1

DIPB –S2

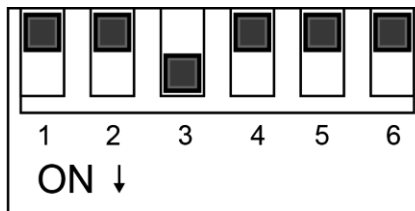
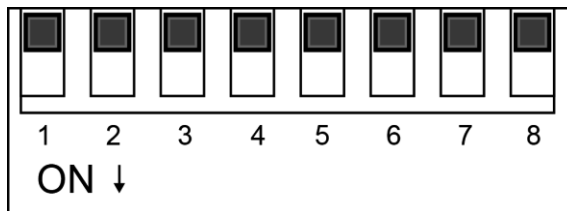

Unit Configuration
WITH Valve

Figure 2

3. Thermoelectric Valve Configuration:

On board DIP switch SW3 of DIPB is used for this configuration.

SW3	Thermoelectric valve (MTV)
1	With valve
0	No valve

0=OFF
1=ON

4. Unit Configuration:

On board DIP switches of DIPB are used for the below configurations.

SW1	PR-O contact setting
0	Economy contact
1	Window contact

SW2	System setting
0	2-pipes system
1	4-pipes system

SW4	Preheat setting
1	82.4°F
0	96.8°F

5. Motorized Fan Speed Settings for Different Models on DIPB:

Unit Model	Speed (RPM)			SW3	SW5	SW6
	Low	Medium	High			
HW-04	500	600	700	0	0	0
HW-06	600	700	900	0	1	0
HW-12	600	700	950	0	0	1
HW-15	700	800	1100	0	1	1
HW-18	900	1100	1300	1	0	0
HW-20	800	900	1100	1	0	1
HW-24	900	1100	1200	1	1	0
HW-30	900	1200	1350	1	1	1
Default RPM	900	1200	1350	1	1	1

6. Mode configuration:

DIPA-S1		Model
SW7	SW8	Model setting
0	0	Cool-Heat
0	1	Cool-Heat + booster heater
1	0	Cooling only
1	1	Cool + primary heater

7. Air Conditioner ON/OFF

There are 3 ways to turn the system on or off:

- By the ON/OFF button on the handset or wired wall pad.
- By the programmable timer on the handset or wired wall pad.
- By the manual control button on the air conditioner.

8. Power On Setting

- Handset only user interface: When the power ON signal is received by the air conditioner, the Mode, Fan Speed, Setting temperature and Swing setting will be the same as the handset setting before the last power OFF.
- Wall-pad only OR wall-pad and handset user interface: When the power ON signal is received by the air conditioner, the Mode, Fan Speed, Setting temperature, Swing setting and Timer ON/OFF weekly program will be the same as the wall pad setting before the last power OFF.

D.4. Control Logics For 2-Pipe System

D.4.1. With Thermoelectric Valve Configuration

COOL MODE

- a) MTV2, AUX1 and heater are always off.
- b) If $T_r \geq T_s + 1.8^\circ\text{F}$ (or $+ 7.2^\circ\text{F}$ if economy contact is activated), then cool operation is activated and MTV1 and AUX2 are turned on. Indoor fan runs at set speed.
- c) If $T_r < T_s$, then cool operation is terminated and MTV1 and AUX2 are turned off. Indoor fan runs at set speed.
- d) The range of T_s is $60.8 - 86^\circ\text{F}$
- e) Indoor fan speed can be adjusted to low, medium, high and auto.
- f) When turned on, MTV1 requires 30 seconds before it is fully open.
- g) When turned off, MTV1 requires 120 seconds before it is fully closed.
- h) When the unit is turned off, the indoor fan will shut down after 5 seconds.

LOW TEMPERATURE PROTECTION OF INDOOR COIL

- a) If $T_{i1} \leq 35.6^\circ\text{F}$ for 2 minutes, then MTV1 and AUX2 are turned off. If indoor fan is set for low speed, it will run at medium speed. If it is set at medium or high speed, it will keep running at the same speed.
- b) If $T_{i1} \geq 41^\circ\text{F}$ for 2 minutes, then MTV1 and AUX2 are turned on. Indoor fan runs at set speed.

FAN MODE

- a) Indoor fan runs at the set speed while heater, MTV1, MTV2, AUX1 and AUX2 are turned off.
- b) Indoor fan speed can be adjusted to low, medium and high.

HEAT MODE

Without Electrical Heater

- a) MTV2, AUX2 and heater are always off.
- b) If $T_r \leq T_s - 1.8^\circ\text{F}$ (or $- 7.2^\circ\text{F}$ if economy contact is activated), then heat operation is activated and MTV1 and AUX1 are turned on. Indoor fan runs at the set speed.
- c) If $T_r > T_s$, then heat operation is terminated and MTV1 and AUX1 are turned off. Indoor fan runs at 200RPM.
- d) The range of T_s is $60.8 - 86^\circ\text{F}$.
- e) Indoor fan speed can be adjusted to low, medium, high and auto.
- f) When turned on, MTV1 requires 30 seconds before it is fully open.
- g) When turned off, MTV1 requires 120 seconds before it is fully closed.

With Electrical Heater as Booster

- a) MTV2 and AUX2 are always off.
- b) If $T_r \leq T_s - 1.8^\circ\text{F}$ (or $- 7.2^\circ\text{F}$ if economy contact is activated), then heat operation is activated and MTV1 and AUX1 are turned on. Indoor fan runs at the set speed.
- c) If $T_r > T_s$, then heat operation is terminated and MTV1 and AUX1 are turned off. Indoor fan runs at 200RPM.
- d) If $T_{i1} < 104^\circ\text{F}$, then the electrical heater is turned on. If $104^\circ\text{F} \leq T_{i1} < 113^\circ\text{F}$, then the electrical heater maintains its original state. If $T_{i1} \geq 113^\circ\text{F}$, then the electrical heater is turned off.
- e) The range of T_s is $60.8 - 86^\circ\text{F}$.
- f) Indoor fan speed can be adjusted to low, medium, high and auto.
- g) When turned on, MTV1 requires 30 seconds before it is fully open.
- h) When turned off, MTV1 requires 120 seconds before it is fully closed.

With Electrical Heater as Primary Heat Source

- a) MTV1, MTV2, and AUX2 are always off.
- b) If $Ti2 \leq 86^{\circ}\text{F}$ (or $Ti2$ is damaged or not connected),
 - 1) If $Tr \leq Ts - 1.8^{\circ}\text{F}$ (or -7.2°F if economy contact is activated), then heat operation is activated and the electrical heater and AUX1 are turned on. Indoor fan runs at set speed.
 - 2) If $Tr > Ts$, then heat operation is terminated and the electrical heater and AUX1 are turned off. Indoor fan runs at 200RPM.
- c) If $Ti2 > 86^{\circ}\text{F}$, MTV2 and AUX2 are off.
 - 1) If $Tr \leq Ts - 1.8^{\circ}\text{F}$ (or -7.2°F if economy contact is activated), then heat operation is activated and the electrical heater is turned off while MTV1 and AUX1 are turned on. Indoor fan runs at set speed.
 - 2) If $Tr > Ts$, then heat operation is terminated and MTV1 and AUX1 are turned off. Indoor fan runs at 200RPM.
- d) The range of Ts is $60.8 - 86^{\circ}\text{F}$.
- e) Indoor fan speed can be adjusted to low, medium, high and auto.

PRE-HEATWithout Electrical Heater

- a) If $Ti1 < 96.8^{\circ}\text{F}$ (or 82.4°F depending on DIP setting), then MTV1 and AUX1 are turned on, indoor fan runs at 200RPM.
- b) If $Ti1 \geq 100.4^{\circ}\text{F}$ (or 86°F depending on DIP setting), then MTV1 and AUX1 are turned on, indoor fan runs at set speed.
- c) If the indoor coil temperature sensor is damaged, then the pre-heat time is set for 2 minutes. Indoor fan runs at set speed.

With Electrical Heater

- a) If the indoor fan speed $\geq 300\text{rpm}$, then the electrical heater will turn on.

POST-HEATWithout Electrical Heater

- a) If $Ti1 \geq 100.4^{\circ}\text{F}$, then MTV1 and AUX1 are turned off. Indoor fan continues to run at set speed.
- b) If $96.8^{\circ}\text{F} \leq Ti1 \leq 100.4^{\circ}\text{F}$, then MTV1 and AUX1 are turned off. Indoor fan maintains its original state.
- c) If $Ti1 < 96.8^{\circ}\text{F}$, then MTV1 and AUX1 are turned off. Indoor fan runs at 200RPM.
- d) If the indoor coil temperature coil is damaged, then the post-heat time is set for 3 minutes with the indoor fan running at set speed.

With Electrical Heater

- a) Indoor fan will run at 200rpm before the unit turns off for 20 seconds.

OVER-HEAT PROTECTION OF INDOOR COIL

- a) If $Ti1 \geq 167^{\circ}\text{F}$, then MTV1 and AUX1 are turned off. Indoor fan remains on and runs at high speed.
- b) If $Ti1 < 158^{\circ}\text{F}$, then MTV1 and AUX1 are turned on. Indoor fan remains on and runs at set speed.
- c) If the indoor coil temperature sensor is damaged, then the protection mode will be overridden and the unit will work according to the pre-heat and post-heat program.

DEHUMIDIFICATION MODE

- a) MTV2, AUX1 and heater are always off.
- b) If $Tr \geq 77^{\circ}\text{F}$, then MTV1 and AUX2 will be turned on for 3 minutes, and then off for 4 minutes.
- c) If $60.8^{\circ}\text{F} \leq Tr < 77^{\circ}\text{F}$, then MTV1 and AUX2 will be turned on for 3 minutes, and then off for 6 minutes.
- d) If $Tr < 60.8^{\circ}\text{F}$, MTV1 and AUX2 will be turned off for 4 minutes.
- e) At the end of the above dehumidification cycle, the system will decide the next dehumidification control option. Indoor fan will run at low speed throughout the dehumidification process.

AUTOMODE

Without Electric heater and With Electric Heater as Booster

- a) Every time the unit is turned on, MTV1 is on while AUX1, AUX2 and fan are off. MTV2 and the heater are always off. After 120 seconds, the subsequent operation mode is decided according to the following:
 - i. If the coil temperature sensor ($Ti1$) $\geq 96.8^{\circ}\text{F}$, then MTV1, AUX1 and fan turn on or off according to HEAT mode.
 - ii. If $Ti1 < 96.8^{\circ}\text{F}$, then MTV1, AUX2 and fan turn on or off according to COOL mode.
- b) Unit remains in AUTO COOL or AUTO HEAT mode throughout the operating cycle until the user changes the mode manually or restarts the unit.
- c) Should the $Ti1$ sensor fail or be damaged, auto mode will not function.

With Electric Heater as Primary Heat Source

- a) If the current running mode is AUTO COOL mode, it will change over to AUTO HEAT mode upon satisfying all the conditions below:
 - i. $T_s - T_r \geq 1.8^{\circ}\text{F}$ (or -7.2°F if economy contact is activated).
 - ii. MTV1 has stopped ≥ 10 minutes.
- b) If the current running mode is AUTO HEAT mode, it will change over to AUTO COOL mode upon satisfying all the conditions below:
 - i. $T_r - T_s \geq 1.8^{\circ}\text{F}$ (or -7.2°F if economy contact is activated).
 - ii. MTV1 has stopped ≥ 10 minutes.

Note: AUTO COOL or AUTO HEAT operations are the same as COOL or HEAT mode respectively.

D.4.2. Without Thermoelectric Valve Configuration

COOL MODE

- a) Heater, AUX1, MTV1 and MTV2 are always off.
- b) If $T_r \geq T_s + 1.8^\circ\text{F}$ (or $+ 7.2^\circ\text{F}$ if economy contact is activated), then cool operation is activated and AUX2 is turned on. Indoor fan runs at set speed.
- c) If $T_r < T_s$, then cool operation is terminated and AUX2 is off. Indoor fan runs at 200rpm.
- d) The range of T_s is 60.8 - 86F.
- e) Indoor fan speed can be adjusted to low, medium, high and auto.
- f) When the unit is turned off, indoor fan shut down after 5 seconds.

LOW TEMPERATURE PROTECTION OF INDOOR COIL

- a) If $T_{i1} \leq 35.6^\circ\text{F}$ for 2 minutes, then AUX2 is turned off. If low speed is selected via user interface, then indoor fan runs at medium speed. If medium or high speed is selected via user interface, then indoor fan runs at set speed.
- b) If $T_{i1} \geq 41^\circ\text{F}$ for 2 minutes, then AUX2 is turned on. Indoor fan runs at set speed.

FAN MODE

- a) Indoor fan runs at the set speed while heater, AUX1, AUX2, MTV1 and MTV2 are turned off.
- b) Indoor fan speed can be adjusted to low, medium and high.

HEAT MODE

Without electrical heater

- a) MTV1, MTV2, AUX2 and heater are always off.
- b) If $T_r \leq T_s - 1.8^\circ\text{F}$ (or $- 7.2^\circ\text{F}$ if economy contact is activated), then heat operation is activated and AUX1 is turned on. Indoor fan runs at the set speed.
- c) If $T_r > T_s$, then heat operation is terminated and AUX1 is turned off. Indoor fan runs at 200rpm.
- d) The range of T_s is 60.8 - 86°F.
- e) Indoor fan speed can be adjusted to low, medium, high and auto.

With electrical heater as booster

- a) MTV1, MTV2 and AUX2 are always off.
- b) If $T_r \leq T_s - 1.8^\circ\text{F}$ (or $- 7.2^\circ\text{F}$ if economy contact is activated), then heat operation is activated and AUX1 is turned on. Indoor fan runs at the set speed.
- c) If $T_r > T_s$, then heat operation is terminated and AUX1 is turned off. Indoor fan runs at 200 rpm.
- d) If $T_{i1} < 104^\circ\text{F}$, then the electrical heater is turned on. If $104^\circ\text{F} \leq T_{i1} < 113^\circ\text{F}$, then the electrical heater maintains its original state. If $T_{i1} \geq 113^\circ\text{F}$, then the electrical heater is turned off.
- e) The range of T_s is 60.8 - 86°F.
- f) Indoor fan speed can be adjusted to low, medium, high and auto.

PRE-HEATWithout Electrical Heater

- a) MTV1, MTV2 and AUX2 are off.
- b) If $Ti1 < 96.8^{\circ}\text{F}$ (or $> 82.4^{\circ}\text{F}$ is selected by DIPB-S2 position SW4), then AUX1 is turned on while indoor fan remains off.
- c) If $Ti1 \geq 100.4^{\circ}\text{F}$ (or $< 86^{\circ}\text{F}$ is selected by DIPB-S2 position SW4), then AUX1 is turned on while indoor fan runs at set speed.
- d) If the indoor coil temperature sensor is damaged, then the pre-heat time is set for 2 minutes and the indoor fan runs at set speed.

With Electrical Heater

- a) If the indoor fan speed $\geq 300\text{RPM}$, then the electrical heater will turn on.

POST-HEATWith and Without Electrical Heater

- a) AUX1 is turned off. Electrical heater is turned off.
- b) Indoor fan will shut down after the unit has been turned off for 20 seconds.

LOW TEMPERATURE PROTECTION OF INDOOR COIL

- a) If $Ti1 \leq 35.6^{\circ}\text{F}$ for 2 minutes, then AUX2 is turned off. If indoor fan runs at low speed, then it will run at medium speed. If indoor fan runs at medium or high speed, then it will run at set speed.
- b) If $Ti1 \geq 41^{\circ}\text{F}$ for 2 minutes, then AUX2 is turned on. Indoor fan runs at set speed.

OVER-HEAT PROTECTION OF INDOOR COIL

- a) If $Ti1 \geq 167^{\circ}\text{F}$, then AUX1 is turned off. Indoor fan remains on and runs at high speed.
- b) If $Ti1 < 158^{\circ}\text{F}$, then AUX1 is turned on. Indoor fan remains and runs at set speed.
- c) If the indoor coil temperature sensor is damaged, then the protection mode will be overridden and the unit will work according to the pre-heat and post-heat program.

DEHUMIDIFICATION MODE

- a) MTV1, MTV2, AUX1 and heater are always off.
- b) If $Tr \geq 77^{\circ}\text{F}$, then the indoor fan and AUX2 will be turned on for 3 minutes, and then off for 4 minutes.
- c) If $60.8^{\circ}\text{F} \leq Tr < 77^{\circ}\text{F}$, then the indoor fan and AUX2 will be turned on for 3 minutes, and then off for 6 minutes.
- d) If $Tr < 60.8^{\circ}\text{F}$, then the indoor fan and AUX2 will be turned off for 4 minutes.
- e) At the end of the above dehumidification cycle, the system will decide the next dehumidification control option. Indoor fan will run at low speed throughout the dehumidification process.

AUTO-MODE

Not available.

D.5. Control Logics For 4-Pipe System

Note: unit equipped with 4x2 switching device.

COOL MODE

- a) MTV2, AUX1 and Electrical Heater are always off.
- b) If $Tr \geq Ts + 1.8^{\circ}F$ (or $+ 7.2^{\circ}F$ if economy contact is activated), then cool operation is activated, MTV1 and AUX2 are turned on. Indoor fan runs at set speed.
- c) If $Tr < Ts$, then cool operation is terminated, MTV1 and AUX2 are turned off. Indoor fan runs at set speed.
- d) The range of Ts is $60.8 - 86^{\circ}F$
- e) Indoor fan speed can be adjusted to low, medium, high and auto.
- f) When turned on, MTV1 requires 30 seconds before it is fully open.
- g) When turned off, MTV1 requires 120 seconds before it is fully closed.
- h) When the unit is turned off, the indoor fan will shut down after 5 seconds.

FAN MODE

- a) Indoor fan runs at the set speed while heater, MTV1, MTV2, AUX1 and AUX2 are turned off.
- b) Indoor fan speed can be adjusted to low, medium and high.

HEAT MODE

Without Electrical Heater

- a) MTV1, AUX2 and electric heater are always off.
- b) If $Tr \leq Ts - 1.8^{\circ}F$ (or $- 7.2^{\circ}F$ if economy contact is activated), then heat operation is activated and MTV2 and AUX1 are turned on. Indoor fan runs at the set speed.
- c) If $Tr > Ts$, then heat operation is terminated and MTV2 and AUX1 are turned off. Indoor fan runs at 200RPM.
- d) The range of Ts is $68.8 - 86^{\circ}F$.
- e) Indoor fan speed can be adjusted to low, medium, high and auto.
- f) When turned on, MTV2 requires 30 seconds before it is fully open.
- g) When turned off, MTV2 requires 120 seconds before it is fully closed.

With Electrical Heater as Booster

- a) MTV1 and AUX2 are always off.
- b) If $Tr \leq Ts - 1.8^{\circ}F$ (or $- 7.2^{\circ}F$ if economy contact is activated), then heat operation is activated and MTV2 and AUX1 are turned on. Indoor fan runs at the set speed.
- c) If $Tr > Ts$, then heat operation is terminated and MTV2 and AUX1 are turned off. Indoor fan runs at 200RPM.
- d) If $Ti1 < 104^{\circ}F$, then the electrical heater is turned on. If $104^{\circ}F \leq Ti1 < 113^{\circ}F$, then the electrical heater maintains its original state. If $Ti1 \geq 113^{\circ}F$, then the electrical heater is turned off.
- e) The range of Ts is $60.8 - 86^{\circ}F$.
- f) Indoor fan speed can be adjusted to low, medium, high and auto.
- g) When turned on, MTV2 requires 30 seconds before it is fully open.
- h) When turned off, MTV2 requires 120 seconds before it is fully closed.

PRE-HEAT

Without Electrical Heater

- a) If $Ti1 < 96.8^{\circ}F$ [or $82.4^{\circ}F$ depending on DIP setting], then MTV2 and AUX1 are turned on. Indoor fan runs at 200RPM.
- b) If $Ti1 \geq 100.4^{\circ}F$ [or $86^{\circ}F$ depending on DIP setting], then MTV2 and AUX1 are turned on. Indoor fan runs at set speed.
- c) If indoor coil temperature sensor is damaged, then the pre-heat time is set for 2 minutes. Indoor fan runs at set speed.

Pre-heat with Electrical Heater

- a) MTV2 and AUX2 are turned on.
- b) If the indoor fan speed $\geq 300\text{RPM}$, then the electrical heater will turn on.

POST-HEATWithout Electrical Heater

- a) If $Ti2 \geq 100.4^\circ\text{F}$, then MTV2 and AUX 1 are turned off. Indoor fan continues to run at set speed.
- b) If $96.8^\circ\text{F} \leq Ti2 \leq 100.4^\circ\text{F}$, then MTV2 and AUX1 are turned off. Indoor fan maintains its original state.
- c) If $Ti2 < 96.8^\circ\text{F}$ then MTV2 and AUX1 are turned off. Indoor fan repeatedly runs for 30 seconds and then stops for 3 minutes.
- d) If the indoor coil temperature sensor is damaged, then the post-heat time is set for 3 minutes. Indoor fan running at set speed.

With Electrical Heater

- a) Indoor fan runs at 200RPM after the unit has been turned off for 20 seconds.

LOW TEMPERATURE PROTECTION OF INDOOR COIL

- a) If $Ti1 \leq 35.6^\circ\text{F}$ for 2 minutes, then MTV1 and AUX2 are turned off. If indoor fan is set for low speed, then it will run at medium speed. If it is set at medium or high speed, then it will keep running at the same speed.
- b) If $Ti1 \geq 41^\circ\text{F}$ for 2 minutes, then MTV1 and AUX2 are turned on. Indoor fan runs at set speed.

OVER HEAT PROTECTION OF INDOOR COIL

- a) If $Ti2 \geq 167^\circ\text{F}$, then MTV2 and AUX1 are turned off. Indoor fan remains on and runs at high speed.
- b) If $Ti2 < 158^\circ\text{F}$, then MTV2 and AUX1 are turned on. Indoor fan remains on and runs at set speed.
- c) If the indoor coil temperature sensor is damaged, then the protection mode will be overridden and the unit will work according to the pre-heat and post-heat set times.

DEHUMIDIFICATION MODE

- a) MTV2, AUX1 and heater are always off.
- b) If $Tr \geq 77^\circ\text{F}$, then MTV1 and AUX2 will be turned on for 3 minutes, and then off for 4 minutes.
- c) If $60.8^\circ\text{F} \leq Tr < 77^\circ\text{F}$, then MTV1 and AUX2 will be turned on for 3 minutes, and then off for 6 minutes.
- d) If $Tr < 60.8^\circ\text{F}$, then MTV1 and AUX2 will be turned off for 4 minutes.
- e) At the end of the above dehumidification cycle, the system will decide the next dehumidification control option. Indoor fan will run at low speed throughout the dehumidification process.

AUTO-MODE

- a) If the current running mode is AUTO COOL mode, it will change over to AUTO HEAT mode upon satisfying all the conditions below:
 - i. $Ts - Tr \geq 1.8^\circ\text{F}$ (or -7.2°F if economy contact is activated).
 - ii. MTV1 has stopped ≥ 10 minutes.
- b) If the current running mode is AUTO HEAT mode, it will change over to AUTO COOL mode upon satisfying all the conditions below:
 - i. $Tr - Ts \geq 1.8^\circ\text{F}$ (or $+7.2^\circ\text{F}$ if economy contact is activated).
 - ii. MTV2 has stopped ≥ 10 minutes.

Note: AUTO COOL or AUTO HEAT operations are the same as COOL or HEAT mode respectively.

D.6. SLEEP MODE

- a) The sleep mode can only be set when the unit is in cool mode or heat mode.
- b) If the sleep mode is activated when the unit is in cooling, the indoor fan will run at low speed and T_s will increase 2.6 °F during 2 hours.
- c) If the sleep mode is activated when the unit is in heating, the indoor fan will run at set speed and T_s will decrease 3.6 °F during 2 hours.
- d) Changing the mode of operation will cancel the sleep mode.

The cool mode sleep profile is:

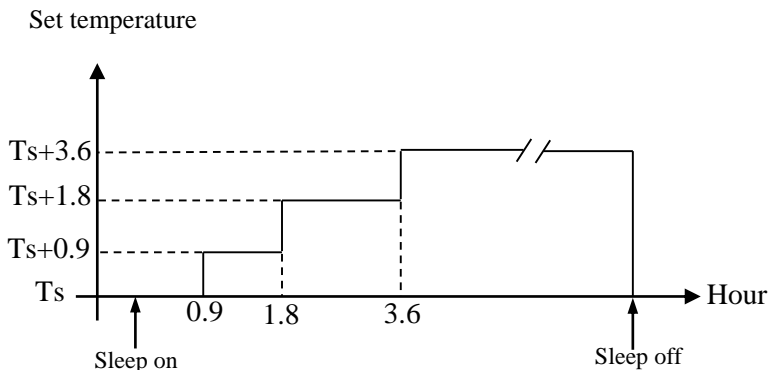

The heat mode sleep profile is:

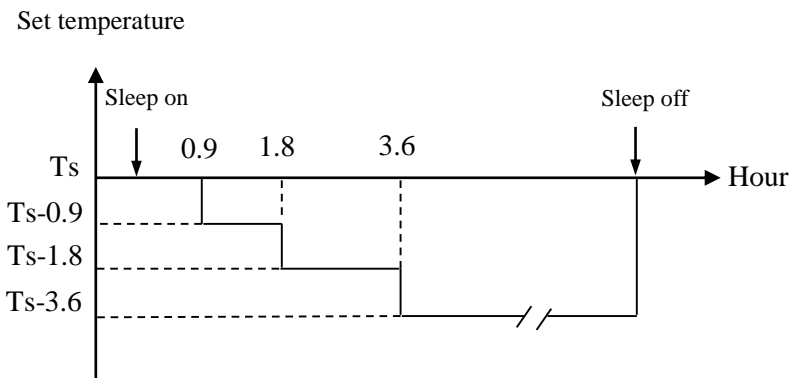

D.7. Auto Fan Speed

- a) In COOL mode, the fan speed cannot change until it has run for more than 30 seconds. Fan speed is regulated according to the profile below.
- b) In HEAT mode, the fan speed cannot change until it has run for more than 30 seconds.

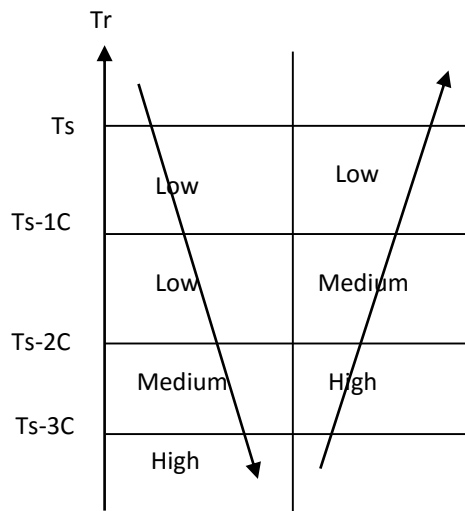
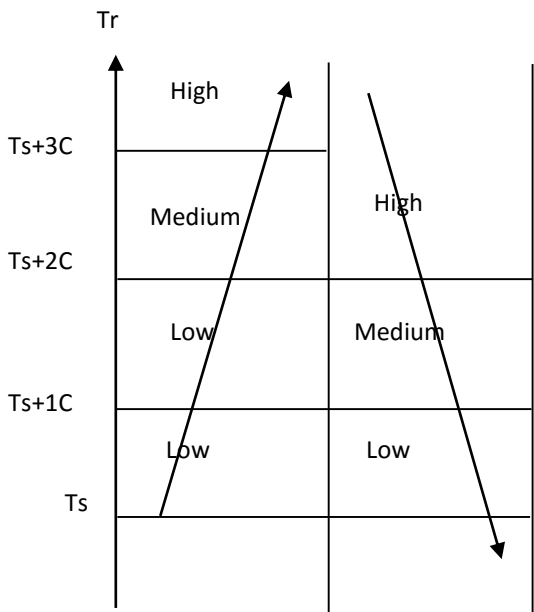

D.8. Louver

For remote handset

Whenever the indoor fan is running, the louver can swing or stop at the desired position.

Louver angle: 0~100°, opens clockwise with widest angle at 100°.

Swing angle: 35~100°, opens clockwise to 68°. Below are the 4 fixed positions which can be set from wireless LCD handset.

Position	Angle
1	35°
2	57°
3	83°
4	100°

For wired wall pad

Louver angle: 0~100°, opens clockwise, with widest angle at 100°.

Swing angle: 35~100°, opens clockwise to 68°. User may stop louver at any desired position between 35~100°.

D.9. Buzzer

If a command is received by the air conditioner, the master unit will respond with 2 beeps for each setting, while the slave unit will respond with 1 beep.

D.10. Auto Restart

The system uses non-volatile memory to save the present operation parameters when system is turned off or in case of system failure or cessation of power supply. When power supply resumes or the system is switched on again, the same operations as previously set will function.

Operation parameters

- when using a handset are Mode, Set Temperature, Swing, and Fan Speed
- when using a wall pad parameters are Mode, Set Temperature, Swing, and Fan Speed, as well as the 7-day ON/OFF Timer program.

D.11. Operation Of Control Panel On High-Wall Unit

D.11.1. On/Off Switch

- This is a tact switch to select COOL → HEAT → OFF operation mode.
- In COOL mode, the set temperature of the system is 75.2°F with auto fan speed and swing. There are no timer and SLEEP modes.
- In HEAT mode, the set temperature of the system is 75.2°F with auto fan speed and swing. There are no timer and SLEEP modes.
- Master unit that does not use a LCD wall pad will globally broadcast.

Note: When button pressing is effective, the master unit buzzer will beep twice and the slave unit will beep once.

D.11.2. Electric Heater Safety Switch (on control PCB)

- Before the electrical heater is turned on, the EH safety switch must be closed. If this contact is opened continuously ≥ 1 second, the heater will be turned off immediately and report an error.
- Once the contact is returned to the closed position ≥ 60 seconds, reset the error and the heater will start again.
- Should the EH safety switch be opened ≥ 3 times within 60 minutes, the heater is not allowed to start anymore.
- Turn off the unit to reset the fault, provided that the switch has returned to the closed position.

D.12. LED lights

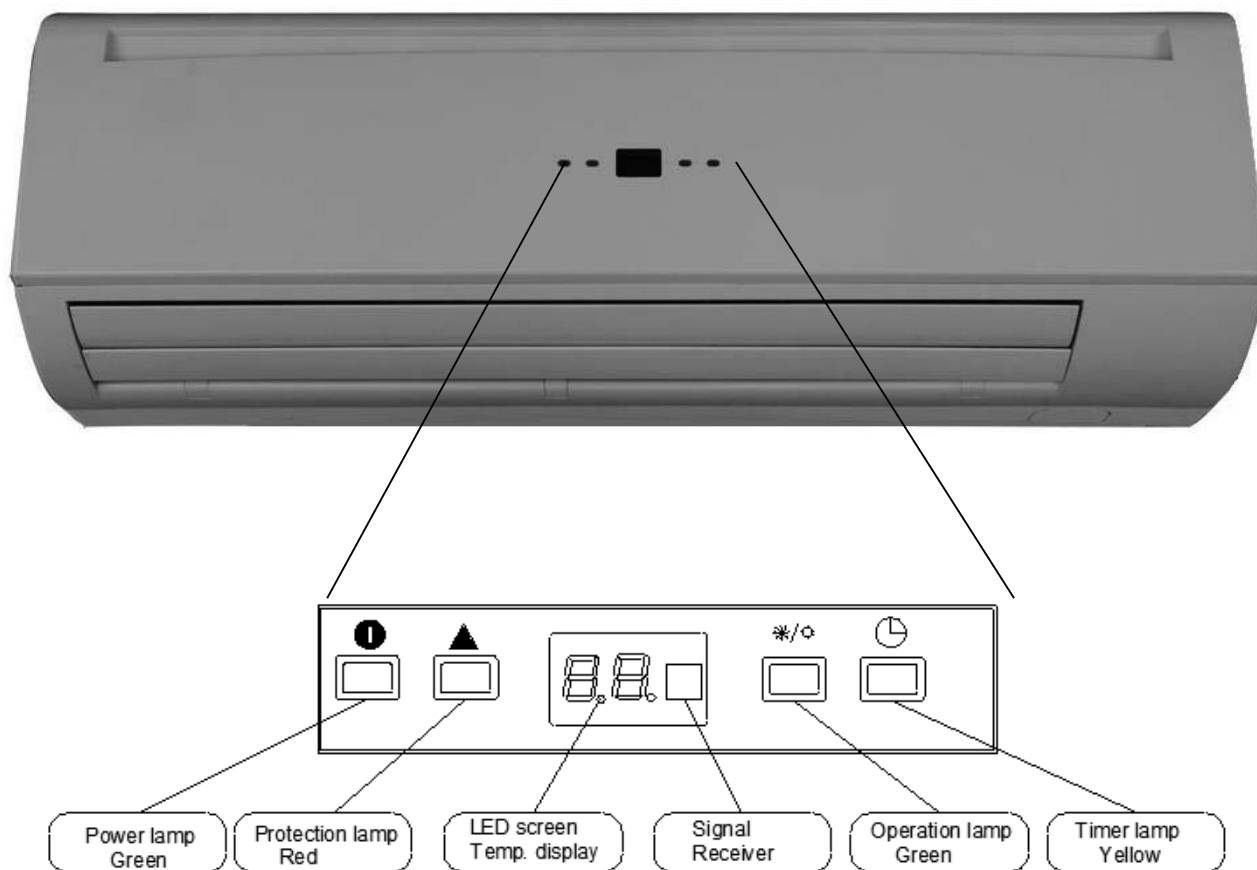

For all units Power / Operation LED light (both green)	
Unit on	Operation LED On, Power LED Off
Unit in standby	Power LED On, Operation LED Off

D.13. LED Display and Error Description

For all units - Operation LED light (Green)			
Error Description	Blink	Reason	Remedy
Electrical heater failure	Green LED blinks 1 times, stops for 3s	<i>Only for unit with EH.</i> EH safety switch is open.	1. Change fan speed to high. 2. Replace the damaged EH safety switch.
Indoor coil sensor 2 failure	Green LED blinks 2 times, stops for 3s	Ti2 sensor unplugged or damaged.	1. Check if Ti2 plug is connected or not. 2. Check if sensor's resistance is correct or not.
Return air sensor failure	Green LED blinks 3 times, stops for 3s	Room sensor unplugged or damaged.	1. Check if Tr plug is connected or not. 2. Check if sensor's resistance is correct or not.
Indoor coil sensor 1 failure	Green LED blinks 4 times, stops for 3s	Ti1 sensor unplugged or damaged.	1. Check if Ti1 plug is connected or not. 2. Check if sensor's resistance is correct or not.
Indoor coil low temperature protection	Green LED blinks 5 times, stops for 3s	Water temperature is lower than 37.4°F.	Check the water temperature.
Indoor coil over heat protection	Green LED blinks 6 times, stops for 3s	Water temperature is higher than 158°F.	Check the water temperature
EC motor failure	Green LED blinks 9 times, stops for 3s	No EC motor feedback	1. Check DIPB-SW5 and SW6 setting. 2. Check the EC motor.

D.14. LED Display on Master/Slave connection

The error message indicating the defect status of all slave units will be shown in LED lights on the master unit.

Master unit Protection LED light (Red)		
Unit No.	Blink	Remedy
Unit 2 failure	RED LED blinks 2 times, stops for 3s	Check unit 2 communication plug and fix it
Unit 3 failure	RED LED blinks 3 times, stops for 3s	Check unit 3 communication plug and fix it
Unit 4 failure	RED LED blinks 4 times, stops for 3s	Check unit 4 communication plug and fix it
Unit 5 failure	RED LED blinks 5 times, stops for 3s	Check unit 5 communication plug and fix it
Unit 6 failure	RED LED blinks 6 times, stops for 3s	Check unit 6 communication plug and fix it
Unit 7 failure	RED LED blinks 7 times, stops for 3s	Check unit 7 communication plug and fix it
Unit 8 failure	RED LED blinks 8 times, stops for 3s	Check unit 8 communication plug and fix it
Unit 9 failure	RED LED blinks 9 times, stops for 3s	Check unit 9 communication plug and fix it
Unit 10 failure	RED LED blinks 10 times, stops for 3s	Check unit 10 communication plug and fix it
Unit 11 failure	RED LED blinks 11 times, stops for 3s	Check unit 11 communication plug and fix it
Unit 12 failure	RED LED blinks 12 times, stops for 3s	Check unit 12 communication plug and fix it
Unit 13 failure	RED LED blinks 13 times, stops for 3s	Check unit 13 communication plug and fix it
Unit 14 failure	RED LED blinks 14 times, stops for 3s	Check unit 14 communication plug and fix it
Unit 15 failure	RED LED blinks 15 times, stops for 3s	Check unit 15 communication plug and fix it
Unit 16 failure	RED LED blinks 16 times, stops for 3s	Check unit 16 communication plug and fix it
Unit 17 failure	RED LED blinks 17 times, stops for 3s	Check unit 17 communication plug and fix it
Unit 18 failure	RED LED blinks 18 times, stops for 3s	Check unit 18 communication plug and fix it
Unit 19 failure	RED LED blinks 19 times, stops for 3s	Check unit 19 communication plug and fix it
Unit 20 failure	RED LED blinks 20 times, stops for 3s	Check unit 20 communication plug and fix it
Unit 21 failure	RED LED blinks 21 times, stops for 3s	Check unit 21 communication plug and fix it
Unit 22 failure	RED LED blinks 22 times, stops for 3s	Check unit 22 communication plug and fix it
Unit 23 failure	RED LED blinks 23 times, stops for 3s	Check unit 23 communication plug and fix it
Unit 24 failure	RED LED blinks 24 times, stops for 3s	Check unit 24 communication plug and fix it
Unit 25 failure	RED LED blinks 25 times, stops for 3s	Check unit 25 communication plug and fix it
Unit 26 failure	RED LED blinks 26 times, stops for 3s	Check unit 26 communication plug and fix it
Unit 27 failure	RED LED blinks 27 times, stops for 3s	Check unit 27 communication plug and fix it
Unit 28 failure	RED LED blinks 28 times, stops for 3s	Check unit 28 communication plug and fix it
Unit 29 failure	RED LED blinks 29 times, stops for 3s	Check unit 29 communication plug and fix it
Unit 30 failure	RED LED blinks 30 times, stops for 3s	Check unit 30 communication plug and fix it
Unit 31 failure	RED LED blinks 31 times, stops for 3s	Check unit 31 communication plug and fix it
Unit 32 failure	RED LED blinks 32 times, stops for 3s	Check unit 32 communication plug and fix it

E. Networking System

E.1. Master – Slave Network

The control PCB can be set either as a master unit or slave unit.

MASTER UNIT FUNCTION

- a) The master unit sends data regarding its setting to the slave unit.
- b) The master unit settings are unit ON/OFF, Mode, Fan Speed, Timer, Clock, Set Temperature, Swing Function, and Sleep Function for handset operation.
- c) The master unit settings are unit ON/OFF, Mode, Fan Speed, Timer, Clock, Set Temperature, Swing Function, and Sleep Function for wall pad operation.

SLAVE UNIT FUNCTION

- a) The slave unit receives data regarding its settings from the master unit.
- b) The slave unit is allowed to change to a locally desired setting by local controller as long as there are no subsequent changes to the settings of the master unit.
- c) The slave units can be set individually for timer ON/OFF function by handset or wall pad. The handset cannot override the wall pad timer and clock setting.

E.1.1.1. Master – Slave Network Setup

1. Disconnect the communication plug from the control box



2. Communication plug

A, B, A, B is printed on the main PCB. When you connect the wires, please ensure connection of A to A and B to B.



3. Connection wire

- i. If the total length of wire is more than 1000m, please use shielded wire in order to protect the signal transmission.
- ii. Complete wire connection

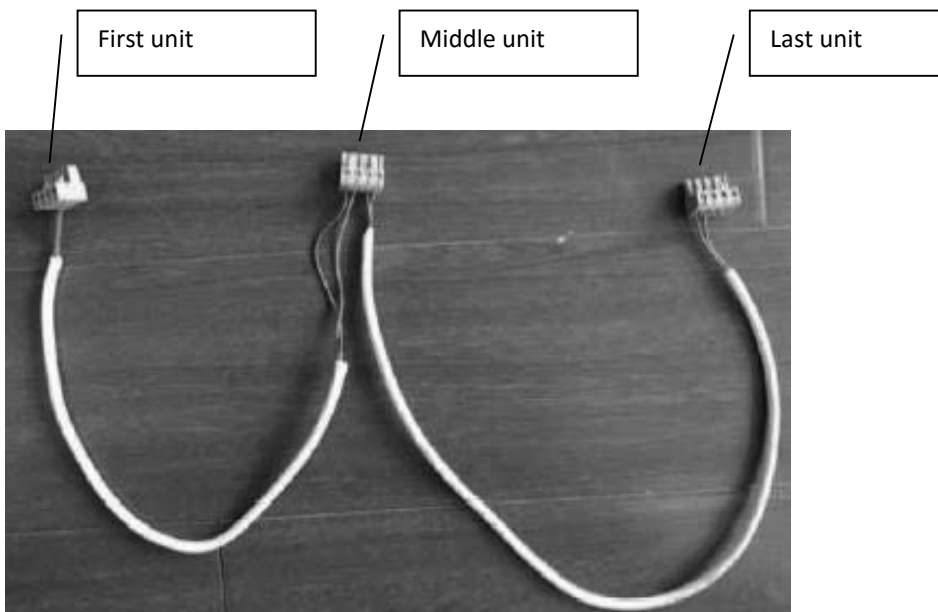

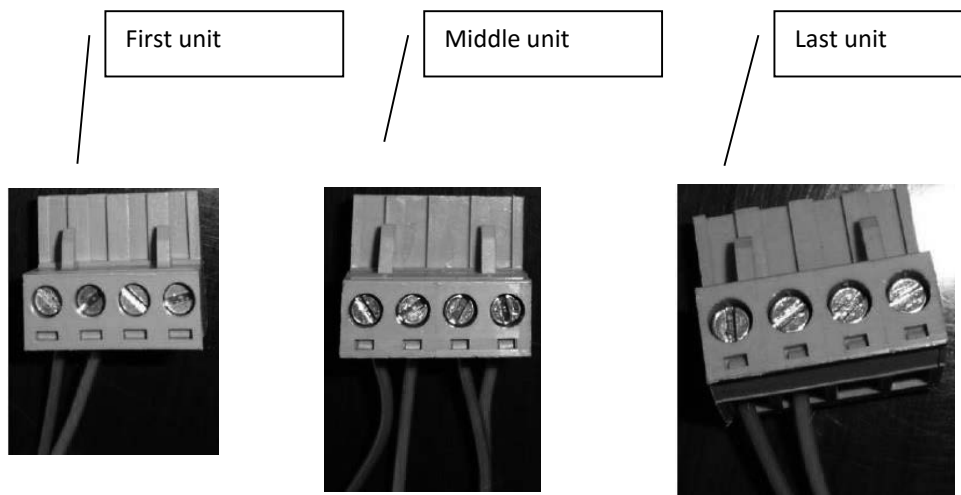

iii. Wire connection check

- 1) After the wire connection is completed, please check that the wire colours correspond.
- 2) Check the wire contact by using a multimeter.

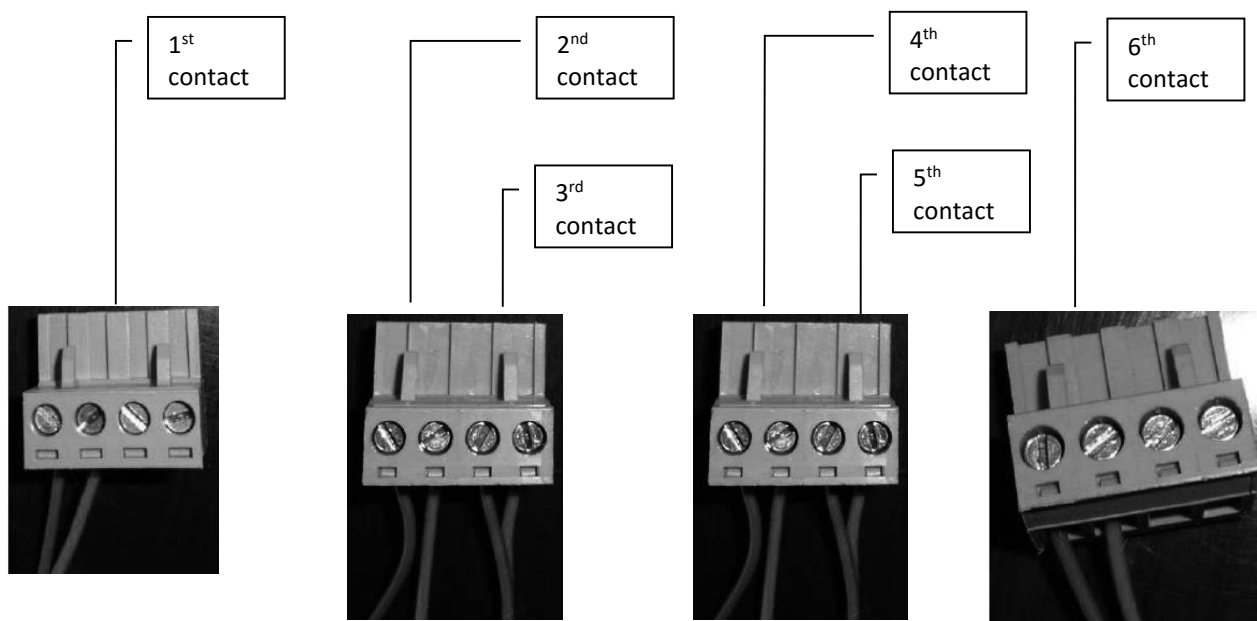

- 3) Check 1 and 2, 3 and 4, 5 and 6 to be sure the connections are correct.
- 4) If the resistance between two wire contacts is too high, please check and reconnect the wire contacts.

4. Reconnect the communication plug to the control box

Using Remote Control Handset to Set Master Control Unit:

- a) Connect all the units PCBs according to the wire color and type of connector.
- b) Select the master unit by setting DIPA-S1 SW6 to ON (=1) in the PCB.
- c) Ensure the DIPA-S1 SW6 is set to OFF (=0) in the PCB on each slave unit.
- d) Switch on the units by connecting the main power supply.
- e) Using the handset, set the operation parameters for the master unit which will automatically send the settings to the slave unit.
- f) Master unit will beep twice confirming receipt of commands while the slave unit will beep once.

Using Wall pad to Set Master Control Unit:

- a) Connect all the units' PCBs according to the wire color and type of connector.
- b) Select the master unit by setting DIPA-S1 SW6 to ON (=1) in the PCB.
- c) Ensure the DIPA-S1 SW6 is set to OFF (=0) in the PCB on each slave unit.
- d) Provide each slave unit with an addressable code by configuring SW1 – SW5 of DIPA-S1 according to the DIP switch setting table.
- e) Switch on the units by connecting the main power supply.
- f) Using the wall pad set the operation parameters for the master unit which will send the setting to the slave units by Global-control communication or Addressable communication methods.
- g) Master unit will beep twice confirming receipt of commands while the slave unit will beep once.

MASTER-SLAVE CONTROL

The control PCB can receive data from both wireless LCD handset and wired wall pad.

E.1.2. Master-Slave Communication Method

There are two modes for Master-slave structure.

Global Control communication

The Master unit will broadcast the settings to all slave units. During normal operation, slave units can receive commands from its local wireless handset and wall pad control panel. Upon reception of master global commands, all slave unit settings will be replaced by the master settings.

Addressable communication

The Master controller must be the LCD wall pad. Slave unit parameters are set as usual. Upon receiving the control commands from a master, the addressed slave unit settings will be replaced by the master settings.

DIPA-S1 address setting: ON=1, OFF=0.

DIPA-S1 SW6	DIPA-S1 SW5	DIPA-S1 SW4	DIPA-S1 SW3	DIPA-S1 SW2	DIPA-S1 SW1	Unit No.	Remark
1	0	0	0	0	0	01	Master
0	0	0	0	0	1	02	Slave
0	0	0	0	1	0	03	Slave
0	0	0	0	1	1	04	Slave
0	0	0	1	0	0	05	Slave
0	0	0	1	0	1	06	Slave
0	0	0	1	1	0	07	Slave
0	0	0	1	1	1	08	Slave
0	0	1	0	0	0	09	Slave
0	0	1	0	0	1	10	Slave
0	0	1	0	1	0	11	Slave
0	0	1	0	1	1	12	Slave
0	0	1	1	0	0	13	Slave
0	0	1	1	0	1	14	Slave
0	0	1	1	1	0	15	Slave
0	0	1	1	1	1	16	Slave
0	1	0	0	0	0	17	Slave
0	1	0	0	0	1	18	Slave
0	1	0	0	1	0	19	Slave
0	1	0	0	1	1	20	Slave
0	1	0	1	0	0	21	Slave
0	1	0	1	0	1	22	Slave
0	1	0	1	1	0	23	Slave
0	1	0	1	1	1	24	Slave
0	1	1	0	0	0	25	Slave
0	1	1	0	0	1	26	Slave
0	1	1	0	1	0	27	Slave
0	1	1	0	1	1	28	Slave
0	1	1	1	0	0	29	Slave
0	1	1	1	0	1	30	Slave
0	1	1	1	1	0	31	Slave
0	1	1	1	1	1	32	Slave

If the master unit is equipped with a wireless handset only, it can only use the Global-Control communication method. If it is equipped with a wall pad, it can use both communication methods.

E.2. Unit Network Wiring Scheme

Wiring diagram for a master-slave network connection

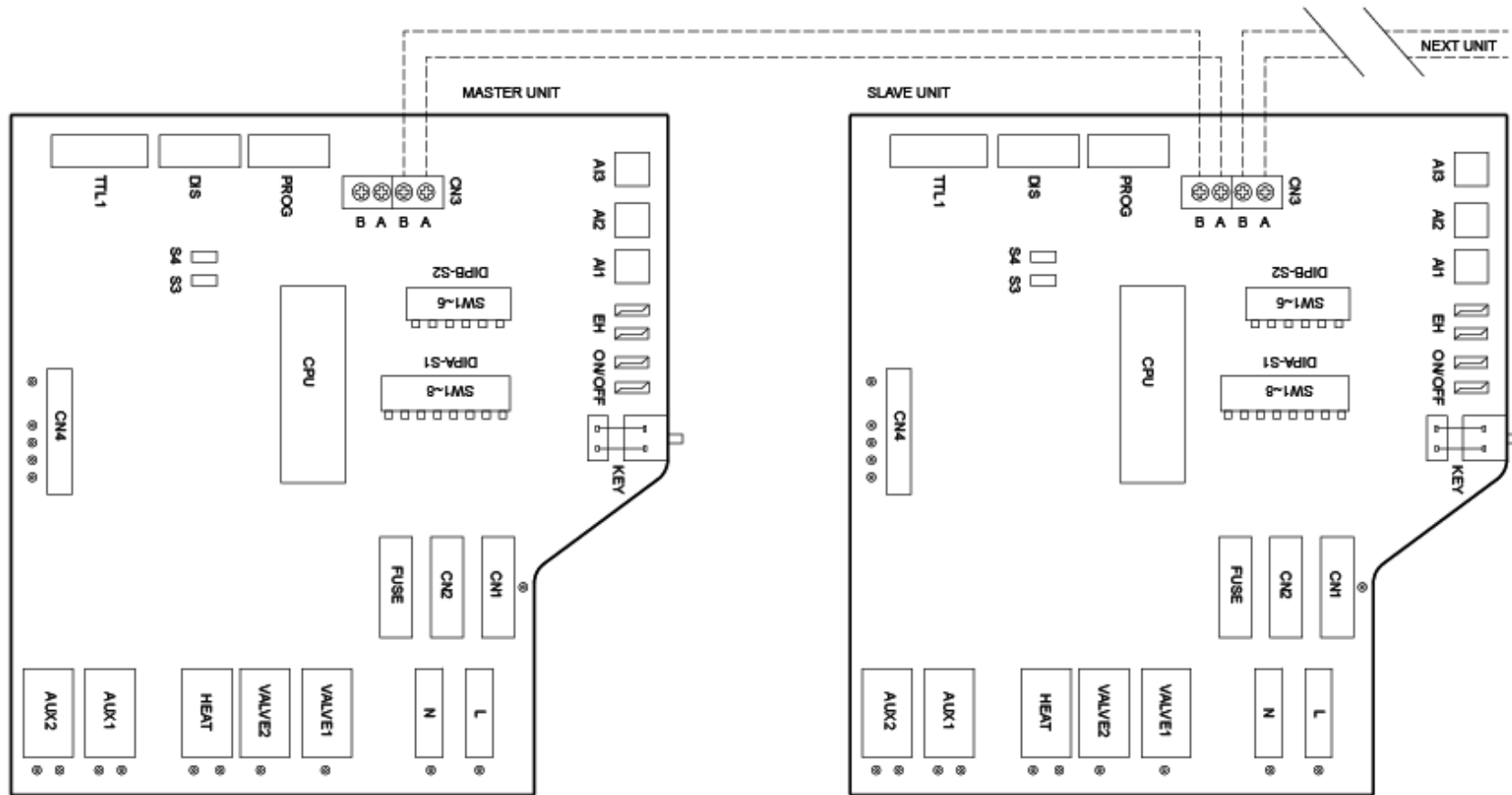

E.3. Open Modbus protocol

Transfer Mode: RTU, BAUD Rate: 9600bps, 8 data bit, 1 stop bit, None parity bit

The communications require a delay of 80ms between reading an answer and sending the next command. All temperatures are equal to reading data*10 accuracy: 0.18°F.

Supported Functions:

Function Code	Function Description
01(01H)	Read Coils
02(02H)	Read Discrete Inputs
03(03H)	Read Holding Registers
04(04H)	Read Input Registers
05(05H)	Write Single Coil
06(06H)	Write Single Register
15(0FH)	Write Multiple Coils
16(10H)	Write Multiple Registers
255(FFH)	Extended Commands which are used to test unit

Valid Error code table:

Error code	Description	Definition
01 (01H)	Invalid commands	Received commands beyond valid commands
02 (02H)	Invalid data address	Data addresses beyond valid data address
03 (03H)	Invalid data	Data beyond definition range
04 (04H)	Write data not successful	Write data did not succeed

Coils table:

Description	Address	Type*	Remark
Unit ON/OFF	100000	R/W	
Sleep mode	100001	R/W	
Louver swing	100002	R/W	
Reserved	100003		
Reserved	100004		
Reserved	100005		
Reserved	100006		
Reserved	100007		
Reserved	100008		
Reserved	100009		
Reserved	100010		
Reserved	100011		
Reserved	100012		
Reserved	100013		
Reserved	100014		
Reserved	100015		

* R = read only, W = write only, R/W = read and write.

Discrete table:

Description	Address	Type*	Remark
MTV1	200000	R	
MTV2	200001	R	
AUX1	200002	R	
AUX2	200003	R	
Condensate pump	200004	R	
Electrical heater	200005	R	
Wired wall pad	200006	R	
PRO	200007	R	
Float switch	200008	R	
Reserved	200009	R	
EH safety switch	200010	R	
Unit ON/OFF status	200011	R	Testing purpose only.

* R = read only, W = write only, R/W = read and write.

Holding Register table:

Description	Address	Type*	Remark
Mode setting	300000	R/W	Cooling mode = 01(H) Humidify mode = 02(H) Fan mode = 04(H) Heating mode = 08(H) Auto mode = 10(H)
Fan speed setting	300001	R/W	Low speed = 04(H) Medium speed = 02(H) High speed = 01(H) Auto fan speed = 07(H)
Louver swing setting	300002	R/W	Position 1 = 01(H) Position 2 = 02(H) Position 3 = 03(H) Position 4 = 04(H) Auto = 0F(H) Stop = 00(H)
Setting temperature	300003	R/W	60.8~86°F (actual*10 format)
Address setting	300004	R	Set by dip-switch, reading only
Reset	300005	W	=0x33 reset error
Week	300006	W	Calibration wired wall pad and set timer function
Hour	300007	W	Calibration wired wall pad and set timer function
Minute	300008	W	Calibration wired wall pad and set timer function
Second	300009	W	Calibration wired wall pad and set timer function
Hours in Timer on	300010	R/W	Timer ON
Minute in Timer on	300011	R/W	Timer ON
Hours in Timer off	300012	R/W	Timer OFF
Minute in Timer off	300013	R/W	Timer OFF
Icon of Timer ON or OFF	300014	R/W	BIT0 = Icon of Timer ON BIT1 = Icon of Timer OFF 1 = enable 0 = disable
Super low speed rpm	310000	R/W	200~1500
Low speed rpm	310001	R/W	200~1500
Medium speed rpm	310002	R/W	200~1500
High speed rpm	310003	R/W	200~1500
RPM setting	310004	R/W	0~2000 (used to test, 0 = disable)
Temperature sampling time	310005	R/W	2~100, default:5S
Factor of auto fan speed	310006	R/W	2~150, default:20
Factor of modulating valve	310007	R/W	2~250, default:150

* R = read only, W = write only, R/W = read and write.

Input Register table:

Description	Address	Type*	Remark
Dip switch 1 status	400000	R	
Dip switch 2 status	400001	R	
Room temperature sensor	400002	R	
Ti1 temperature sensor	400003	R	
Ti2 temperature sensor	400004	R	
Error code	400005	R	Bit0 = Room temperature sensor error Bit1 = Ti1 temperature sensor error Bit2 = Ti2 temperature sensor error Bit3 = Float switch error Bit4 = Indoor coil low temperature protection Bit5 = Indoor coil over heat protection Bit6 = Reserved Bit7 = Electrical heater failure Bit8 = Motor1 Error Bit9 = Motor2 Error Bit10 = System parameters error Bit11 = Reserved Bit12 = Reserved Bit13 = Reserved Bit14 = Reserved Bit15 = Reserved
Fan speed status	400006	R	Low = 04(H) Medium = 02(H) High = 01(H)
Mode status	400007	R	Cooling mode = 01(H) Dehumidify mode = 02(H) Fan mode = 04(H) Heating = 08(H)
Setting temperature status	400008	R	Testing only
Room temperature in wall pad status	400009	R	
Room temperature in main PCB status	400010	R	
Unit type	400011	R	4-pipe = 03, 2-pipe = 02 This setting is configured by dip switch
EC motor 1# RPM	400012	R	
EC motor 2# RPM	400013	R	

* R = read only, W = write only, R/W = read and write.

Remark:

The above protocol address is in **Base 0**.

F. Control Specifications: Flexible Control PCB - W Type Control

Used in all High-Wall [V/P] ~W unit configurations.

Ti1 = Chilled water coil temperature (10K)

F.1. Definition of Input/Output

I/O		Code	2-Pipe
Analogue Input	Chilled water Sensor	AI1	Coil sensor
Power input	R1	Lo	24 Voltage input (NO). If any speed is powered, the unit is turned on. If no speed receives power, the unit is turned off.
	R 2	Med	
	R 3	Hi	
Power input	Phase	L	Power supply: 220V/1Ph/60Hz 115V/1Ph/60Hz
	Neutral	N	
	Earth	GND	
Digital input	Wired wall pad	TTL	Change EC motor rpm
Signal input	AUTO SIGNAL	Auto	24V 60HZ, auto signal on, unit is turned on
	0 to+5VDC (0~10VDC)	Signal	0 to +5VDC · SW1=0 (0~10VDC, SW1=1)
Motor output	EC motor	CN3	
Output	Stepping motor	CN1-2	

F.2. Wiring diagram Flexible Control PCB - W Control Type

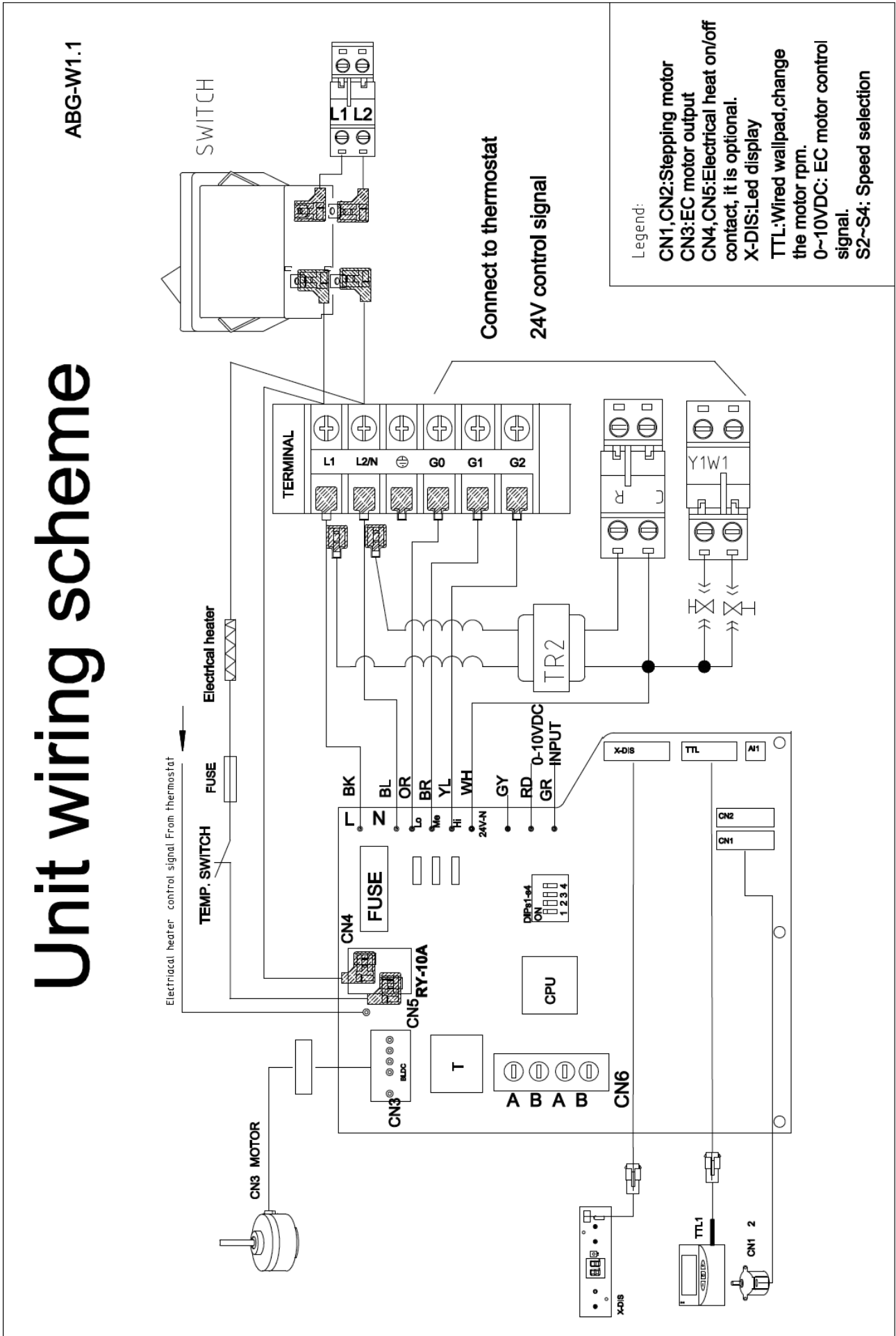

F.3. Onboard configuration

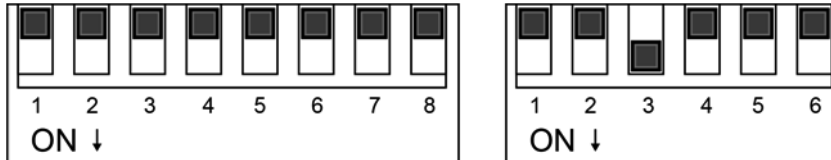

There is 1 DIP switch set on the PCB:

DIPB (4 positions)

- SW1: configured for different modulating signal
- SW2 – SW4: brushless DC fan motor configuration.

Code	State	Description
SW1	0	PCB configured for 0~5VDC modulating signal input.
	1	PCB configured for 0~10VDC modulating signal input.

MODEL	SW2	SW3	SW4	Hi	Med	Low
HW-04	0	0	0	700	600	500
HW-06	0	0	1	900	700	600
HW-12	0	1	0	950	700	600
HW-15	0	1	1	1100	800	700
HW-18	1	0	0	1300	1100	900
HW-20	1	0	1	1100	900	800
HW-24	1	1	0	1200	1100	900
HW-30	1	1	1	1350	1200	900
Default RPM	1	1	1	Set by customer requirement		

F.4. Control Logics

1. Power On Setting

When any fan speed is selected, the unit is turned on. When all of the fan speed inputs (H/M/L) are off, the unit is turned off.

2. Swing / Louver

When the unit is turned on, the louver will open to the largest angle at 100°, then move to the operating angle at 87°. When the unit is turned off, the louver will close.

3. Signal Input

When Auto speed is turned ON, the unit is turned on and the motor runs at 200 RPM. EC motor RPM will be changed by the signal voltage.

F.5. LED Display

For all units Power / Operation LED light (both green)	
Unit on	Operation LED On, Power LED Off
Unit in standby	Power LED On, Operation LED Off

F.6. Error Description

For all units - Operation LED light (Green)			
Item	Blink	Reason	Remedy
Indoor coil sensor 1 failure	Green LED blinks 4 times, stops for 3s	Ti1 sensor connection is unplugged or damaged.	1. Check if Ti1 plug is connected or not. 2. Check if sensor's resistance is correct or not.
EC motor failure	Green LED blinks 9 times, stops for 3s	No EC motor feedback	1. Check if EC motor's wires are connected. 2. Check the EC motor

G. Users Interface

G.1. Remote Control Handset

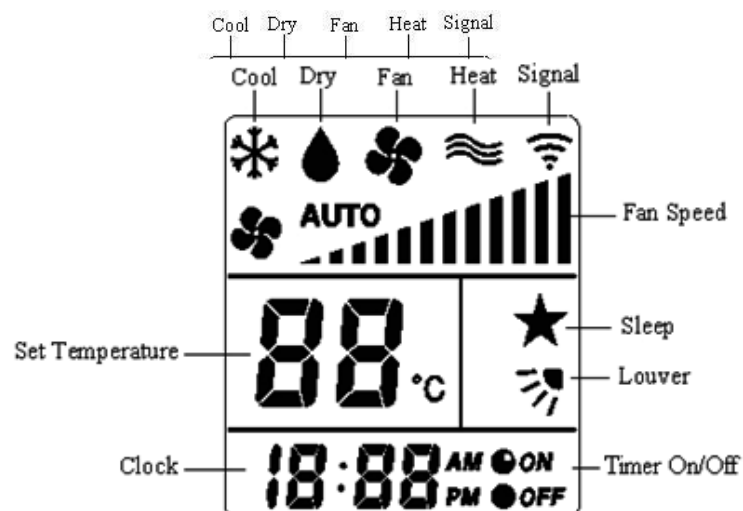
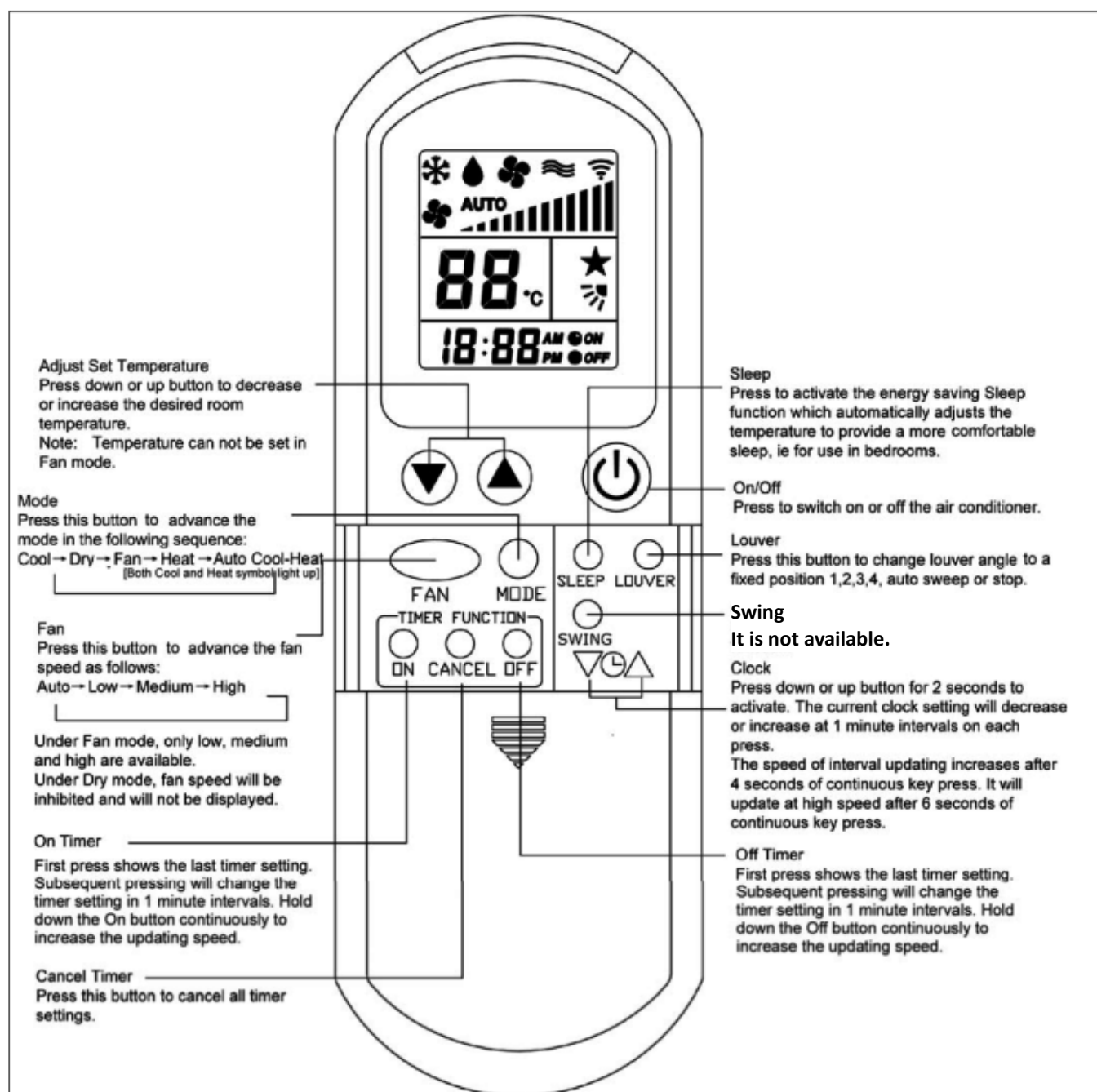

Attention

When unit with handset is the master unit, its settings are automatically sent to the slave units; Auto Cool-Heat operation will be applicable in 4-pipe system only.

“Swing” function is not applicable.
European version only uses degree C setting.

G.2. Wired Wall Pad

G.2.1. Wall Pad Display

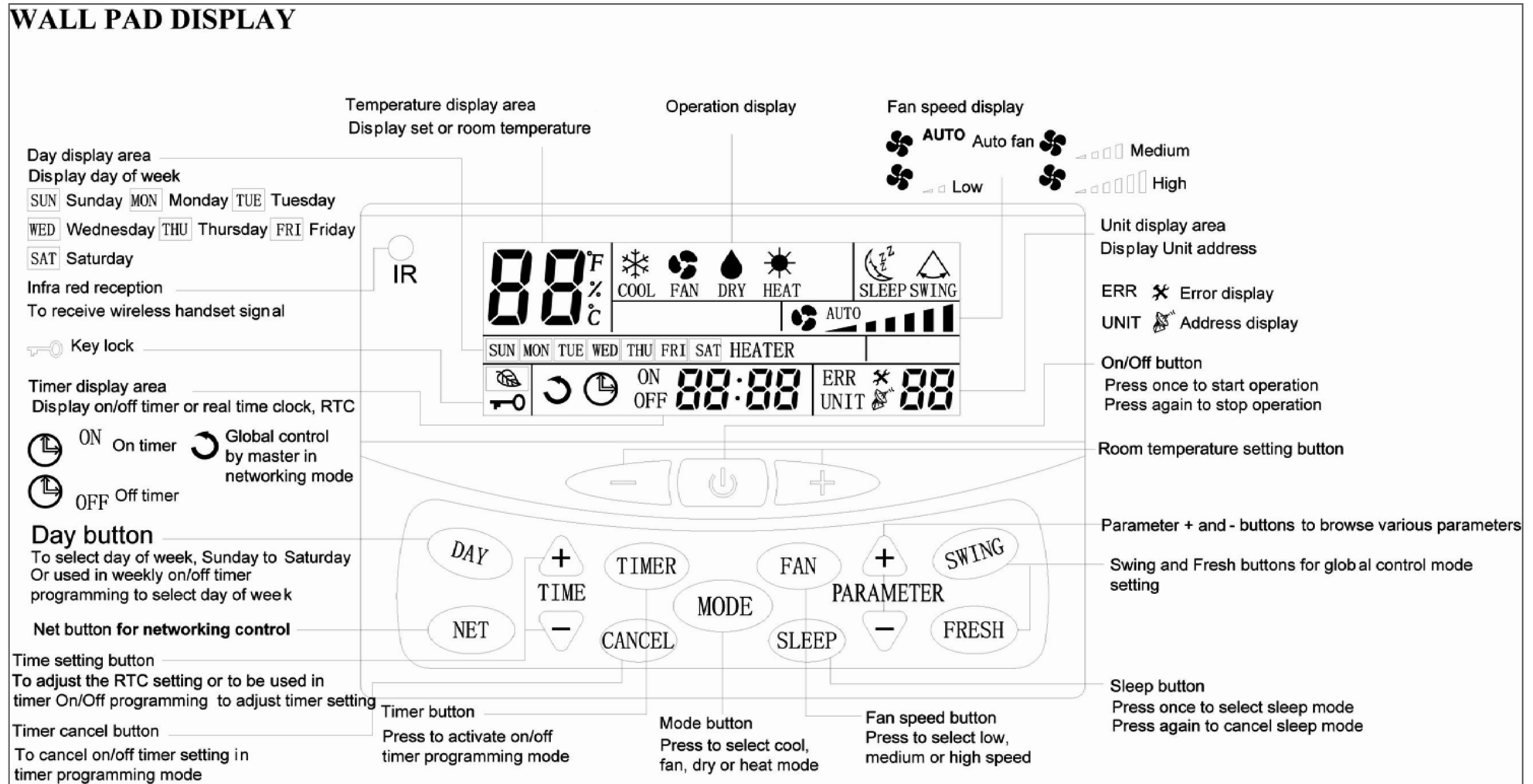



Attention

- Wall pad will recognize the main board model automatically whether it is 2-pipe or 4-pipe system.
- Auto Cool-Heat operation is applicable in 4-pipe system only.
- When the wall pad is installed the wall-pad temperature sensor automatically overrides the default return air sensor (attached near unit return air). European version only uses degree C setting.

G.2.2. Wall Pad Operation Guidelines

a) Clock display and setting











System has an accurate, internal, real time clock used for time indication and timer ON/OFF function. Clock display area indicates internal time clock which can be set by the  or  buttons.

b) Day display and setting











The wall pad has a day display function which is used for day indication and timer ON/OFF function. Day display icon indicates current day. Press  button to set day.

c) Timer ON/OFF setting

If the master unit is in global control mode and the ON/OFF timer setting is selected, the master unit will command the whole network to be ON or OFF. Otherwise the ON/OFF timer affects the local unit only. The system supports ON/OFF timer settings for each day of the week.

- 1) Press  button once,  and **ON** symbol blinking indicates ON timer programming mode. The day display area indicates which day the timer is being set for. If there is no preset ON timer for this day, the timer display area shows $\text{--}^{\circ}\text{--}$, otherwise the previous timer setting will be shown. Press  or  buttons to change the ON timer setting. Press  key to cancel the current ON timer setting and the timer display area will show $\text{--}^{\circ}\text{--}$. Press  button to change the day the ON timer is to be programmed for.
- 2) Press  button again.  and **OFF** symbol blinking indicates OFF timer programming mode. The setting method is the same as the ON timer setting above.
- 3) Press  button again to exit the ON/OFF timer setting function.
- 4) Should there be any ON or OFF timer settings programmed,  will light up. Should there be any unexecuted ON or OFF timer settings for the current day, its corresponding **ON** or **OFF** icon will light up.
- 5) Hold down  button for 3 seconds to cancel all timer settings.

d) Timer set by master unit



- 1) Press  button to enter into networking control mode. Unit area blinking indicates the slave unit under control. Press  or  to select the desired slave unit. Units that are off will be skipped automatically.
- 2) Press  button once to enter into ON timer programming mode. Press  button to select the required day of the week. Master unit will then retrieve the setting from the selected slave unit and the timer display area will show "read". The ON timer setting will be shown upon reading the data successfully. Press  or  button to change the ON timer setting of the slave unit.
- 3) Press  button again to enter into OFF timer programming mode. Press  button to select the required day of the week. Master unit will then retrieve the setting from the selected slave unit and the timer display area will show "read". The OFF timer setting will be shown upon reading the data successfully. Press  or  button to change the OFF timer setting of the slave unit.

- 4) Upon completion of changing timer settings for the selected day, press  button again to exit timer programming mode. The settings will then upload to the selected slave unit. The next day of the week's settings can be done only upon completion of sending data to the slave units. (Repeat steps 1~4 if setting is required for the next day of the week).





In Global control mode:

- Pressing the master unit's  button for 3 seconds will cancel all timer settings in all slave units.
- Timer settings will be broadcast to all slave units.

e) Clock synchronization by master unit is as follows:

Press  and  buttons for 3 seconds to activate clock synchronization in all slave units. Master wall pad will respond with a beeping sound.

f) Key lock

In order to prevent unauthorized access to the system setting, a key lock function is provided. Hold down  and  for 3 seconds to activate key lock.  symbol will light up. Repeat the same to exit key lock. Only  button is applicable in key lock mode.



g) Swing

Press  button to activate or deactivate swing function.

h) Sleep

Press  button to activate or deactivate sleep setting. The sleep function is valid in cool or heat modes only.

i) Temperature setting

Press  or  to enter into temperature setting mode. The temperature display area blinks indicating the current set temperature. Press the above buttons to adjust the set temperature.

j) Mode setting

Press  button to change the operation mode.





k) Fan speed setting



Press  button to change the fan speed. Only low speed is available for dehumidification mode.

l) On/Off control



Press  to start or stop the air conditioner.



m) Networking Master - Slave Control (only master unit wall pad can control other units on the network)

Press  button to enter into networking control mode. Unit's display area blinking indicates the slave unit under control. Press  or  to select the desired slave unit; Units that are off will be bypassed automatically. Parameters that can be controlled are on/off, timer weekly program, set temperature, mode, fan speed, swing and sleep. Parameter operation methods are the same as above. Press  button again to exit networking control mode.

Hold down  and  buttons for 3 seconds to enter into global control mode.  will light up. Repeat the same to exit global control mode. In global control mode, the settings of the master unit will be broadcast to all the slave units.

n) Unit operation parameters browsing

Hold down  and  buttons for 3 seconds to enter into operation parameters browsing mode. Unit display area shows the address of the slave unit being viewed. Slave unit selection method is the same as in

networking control above. Press  or  to browse various parameters as follow:

Wall pad display temperature area	Wall pad display time area
C0	Return air temperature displayed
C1	Indoor coil temperature displayed
C2	DIP switch setting displayed
C3	Indoor coil 2 temperature

Press  button to exit.

o) Error indication

When a faulty slave unit is detected, the master unit's display area shows the faulty unit address, the time area shows the error code and the wall pad backlight changes to the color red. Should there be multiple units having problems, addresses and error codes will be shown one after another.

Error code definition:

Error	Error code
Electrical heater faulty	E1
Indoor coil sensor 2 faulty	E2
Return air sensor faulty	E3
Indoor coil sensor 1 faulty	E4
Indoor coil low temperature protection	E5
Indoor coil over heat protection	E6
Float switch alarm	E7
Local communication error	E8

For units without master-slave settings, the wall pad will indicate unit error codes as above.

G.2.3. EC unit RPM setting

1. Turn OFF the unit.
2. Open wall pad's back cover, where two DIP switches can be seen.
3. Turn the DIP switch 1 to "ON" position.

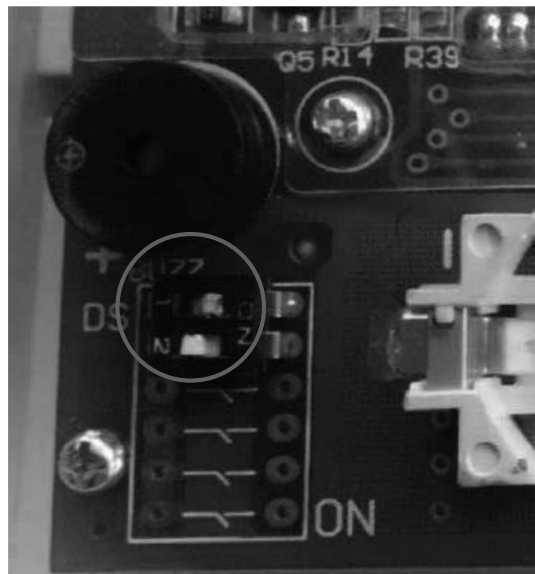
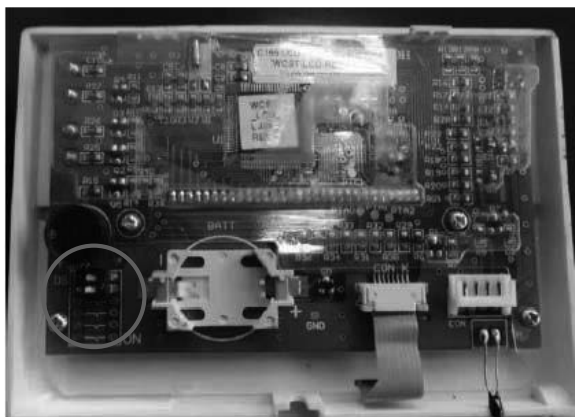

4. Wired wall pad LED will display the following:

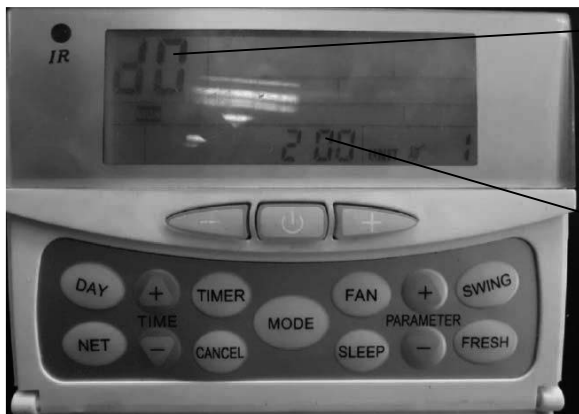

This is the speed level setting.
 d0 means low speed
 d1 means medium speed
 d2 means high speed
 Press PARAMETER +/- button to select.

This is the motor RPM setting.
 Press TEMP. +/- button to increase the RPM setting by 10RPM step.

5. To complete the RPM setting, turn the DIP switch 1 to "OFF" position. The wired wall pad display will resume its normal appearance.

H. Sensor Resistance R-T Conversion Table

Resistance : $R(77^{\circ}\text{F}) = 10\text{K}\Omega \pm 1\%$

Beta Constant : $B(25/85) = 3977 \pm 1\%$

T	Rmin	Rnom	Rmax	T	Rmin	Rnom	Rmax
(°F)	(KΩ)	(KΩ)	(KΩ)	(°F)	(KΩ)	(KΩ)	(KΩ)
-22	174	182.7	191.8	39.2	26.11	26.9	27.71
-20.2	163.4	171.5	179.9	41	24.85	25.59	26.34
-18.4	153.6	161.1	168.9	42.8	23.65	24.35	25.05
-16.6	144.4	151.3	158.5	44.6	22.52	23.17	23.83
-14.8	135.8	142.2	148.9	46.4	21.45	22.06	22.68
-13	127.8	133.8	140	48.2	20.44	21.01	21.59
-11.2	120.3	125.8	131.6	50	19.48	20.02	20.55
-9.4	113.3	118.4	123.8	51.8	18.58	19.7	19.58
-7.6	106.7	111.5	116.5	53.6	17.71	18.18	18.65
-5.8	100.6	105.1	109.7	55.4	16.9	17.33	17.77
-4	94.9	99.03	103.3	57.2	16.12	16.53	16.94
-2.2	89.51	93.39	97.41	59	15.39	15.77	16.16
-0.4	84.5	88.11	91.85	60.8	14.69	15.05	15.41
1.4	79.8	83.17	86.64	62.6	14.03	14.37	14.7
3.2	75.39	78.53	81.76	64.4	13.41	13.72	14.03
5	71.26	74.18	77.19	66.2	12.81	13.1	13.4
6.8	67.37	70.1	72.9	68	12.24	12.52	12.79
8.6	63.73	66.26	68.88	69.8	11.7	11.96	12.22
10.4	60.3	62.67	65.1	71.6	11.19	11.43	11.67
12.2	57.08	59.28	61.55	73.4	10.71	10.93	11.15
14	54.05	56.1	58.22	75.2	10.24	10.45	10.66
15.8	51.19	53.12	55.08	77	9.8	10	10.2
17.6	48.51	50.3	52.14	78.8	9.374	9.57	9.765
19.4	45.98	47.66	49.37	80.6	8.969	9.16	9.351
21.2	43.61	45.17	46.77	82.4	8.584	8.77	8.957
23	41.36	42.82	44.31	84.2	8.218	8.4	8.582
24.8	39.25	40.61	42	86	7.869	8.047	8.225
26.6	37.26	38.53	39.83	87.8	7.537	7.71	7.885
28.4	35.38	36.56	37.78	89.6	7.221	7.39	7.56
30.2	33.6	34.71	35.85	91.4	6.92	7.085	7.251
32	31.93	32.97	34.02	93.2	6.633	6.794	6.956
33.8	30.35	31.32	32.3	95	6.36	6.517	6.675
35.6	28.85	29.76	30.68	96.8	6.099	6.252	6.407
37.4	27.44	28.29	29.15	98.6	5.85	6	6.151

Resistance : $R(77^{\circ}\text{F}) = 10\text{K}\Omega \pm 1\%$ Beta Constant : $B(25/85) = 3977 \pm 1\%$

T (°F)	Rmin (KΩ)	Rnom (KΩ)	Rmax (KΩ)	T (°F)	Rmin (KΩ)	Rnom (KΩ)	Rmax (KΩ)
100.4	5.614	5.759	5.907	167	1.417	1.474	1.532
102.2	5.387	5.53	5.673	168.8	1.37	1.426	1.482
104	5.172	5.31	5.451	170.6	1.326	1.379	1.434
105.8	4.966	5.101	5.238	172.4	1.282	1.335	1.389
107.6	4.769	4.901	5.034	174.2	1.241	1.292	1.344
109.4	4.582	4.71	4.84	176	1.201	1.25	1.302
111.2	4.402	4.527	4.654	177.8	1.162	1.211	1.261
113	4.231	4.353	4.477	179.6	1.125	1.172	1.221
114.8	4.067	4.186	4.307	181.4	1.089	1.135	1.183
116.6	3.911	4.027	4.144	183.2	1.055	1.1	1.146
118.4	3.761	3.874	3.989	185	1.021	1.065	1.111
120.2	3.618	3.728	3.84	186.8	0.9891	1.032	1.077
122	3.481	3.588	3.697	188.6	0.9582	1	1.044
123.8	3.35	3.454	3.561	190.4	0.9284	0.9697	1.012
125.6	3.225	3.326	3.43	192.2	0.8998	0.9401	0.9818
127.4	3.105	3.204	3.305	194	0.8721	0.9115	0.9522
129.2	2.99	3.086	3.185	195.8	0.8455	0.8839	0.9237
131	2.88	2.974	3.07	197.6	0.8198	0.8573	0.8961
132.8	2.774	2.866	2.959	199.4	0.795	0.8316	0.8696
134.6	2.673	2.762	2.854	201.2	0.7711	0.8069	0.8439
136.4	2.576	2.663	2.752	203	0.748	0.783	0.8192
138.2	2.483	2.568	2.655	204.8	0.7258	0.7599	0.7953
140	2.394	2.477	2.562	206.6	0.7043	0.7376	0.7722
141.8	2.309	2.39	2.472	208.4	0.6836	0.7161	0.7499
143.6	2.227	2.306	2.386	210.2	0.6635	0.6953	0.7283
145.4	2.149	2.225	2.304	212	0.6442	0.6752	0.7075
147.2	2.073	2.148	2.224	213.8	0.6255	0.6558	0.6874
149	2.001	2.074	2.148	215.6	0.6075	0.6371	0.6679
150.8	1.931	2.002	2.075	217.4	0.59	0.619	0.6491
152.6	1.865	1.934	2.005	219.2	0.5732	0.6015	0.631
154.4	1.801	1.868	1.937	221	0.5569	0.5846	0.6134
156.2	1.739	1.805	1.872				
158	1.68	1.744	1.81				
159.8	1.623	1.686	1.75				
161.6	1.569	1.63	1.692				
163.4	1.516	1.576	1.637				
165.2	1.466	1.524	1.583				

I. Troubleshooting Guide

