

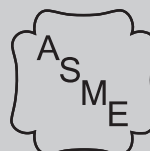

Condensing, High Efficiency Water Heaters (IW) and Boilers (IB)

Boiler Manual Installation and Operation Instructions

THIS MANUAL APPLIES TO
HEATERS WITH SERIAL NUMBER
HIGHER THAN 18170091



62403588 R07 Jun. 13, 2018

WARNING This manual is intended only for use by a qualified heating installer/technician. Read and follow this manual, all supplements and related instructional information provided with the boiler. Install, start and service the boiler only in the sequence and methods given in these instructions. Failure to do so can result in severe personal injury, death or substantial property damage.

WARNING **Do not use the boiler during construction.** Construction dust and particulate, particularly drywall dust, will cause contamination of the burner, resulting in possible severe personal injury, death or substantial property damage. The boiler can only be operated with a dust-free air supply. Follow the instruction manual procedures to duct air to the boiler air intake. If the boiler has been contaminated by operation with contaminated air, follow the instruction manual guidelines to clean, repair or replace the boiler if necessary.

CAUTION Affix these instructions near to the boiler. Instruct the building owner to retain the instructions for future use by a qualified service technician, and to follow all guidelines in the User's Information Manual.

SAFETY INSTRUCTIONS

WARNING: If the information in these instructions is not followed exactly, a fire or explosion may result causing property damage, personal injury or death.

- Do not store or use gasoline or other flammable vapors and liquids in the vicinity of this or any other appliance.
- **WHAT TO DO IF YOU SMELL GAS**
 - Do not try to light any appliance.
 - Do not touch any electrical switch; do not use any phone in your building.
 - Immediately call your gas supplier from a neighbor's phone. Follow the gas supplier's instructions.
 - If you cannot reach your gas supplier, call the fire department.
- Installation and service must be performed by a qualified installer, service agency or the gas supplier.

	<p>Water temperature over 125°F (51°C) can cause severe burns instantly or death from scalds.</p> <p>Children, disabled and elderly are at highest risk of being scalded.</p> <p>See instruction manual before setting temperature of water heater.</p> <p>Feel water before bathing or showering.</p> <p>Temperature limiting valves are available, see manual.</p>
---	--

121110m0_a

SAFETY INSTRUCTIONS

FOR YOUR SAFETY READ BEFORE OPERATING

WARNING: If you do not follow these instructions exactly, a fire or explosion may result causing property damage, personal injury or loss of life.

- A. This appliance does not have a pilot. It is equipped with an ignition device which automatically lights the burner. Do not try to light the burner by hand.
- B. BEFORE OPERATING smell all around the appliance area for gas. Be sure to smell next to the floor because some gas is heavier than air and will settle on the floor.

WHAT TO DO IF YOU SMELL GAS

- Do not try to light any appliance.
- Do not touch any electric switch;
- Do not use any phone in your building.
- Immediately call your gas supplier from a neighbor's phone. Follow the gas supplier's instructions.



- If you cannot reach your gas supplier, call the fire department.

C. Use only your hand to push in or turn the gas control knob. Never use tools. If the knob will not push in or turn by hand, don't try to repair it, call a qualified service technician. Force or attempted repair may result in a fire or explosion.

D. Do not use this appliance if any part has been under water. Immediately call a qualified service technician to inspect the appliance and to replace any part of the control system and any gas control which has been under water.

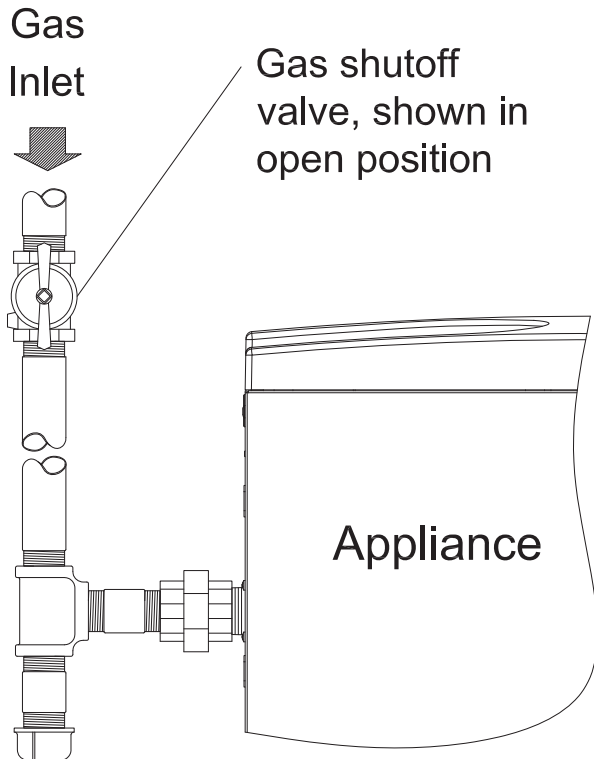
OPERATING INSTRUCTIONS



1. STOP! Read the safety information above (to the left) on this label.
2. Turn off all electric power to the appliance.
3. Set the main switch to zero.
4. This appliance is equipped with an ignition device which automatically lights the burner. Do not try to light the burner by hand.
5. Close the manual gas shutoff valve turning the knob clockwise . Do not force.
6. Wait five (5) minutes to clear out any gas. Then smell for gas, including near the floor. If you smell gas, STOP! Follow "B" in the safety information above (to the left) on this label. If you don't smell gas, go to the next step.
7. Open the manual gas shutoff valve turning the knob counterclockwise .
8. Turn on all electric power to the appliance, and set the main switch to the on position.
9. Set an heating request following the installation manual.
10. If the appliance will not operate, follow the instructions "To Turn Off Gas To Appliance" and call your service technician or gas supplier.

TO TURN OFF GAS TO APPLIANCE

1. Turn off all electric power to the appliance if service is to be performed.
2. Set the main switch to zero.
3. Close the manual gas shutoff valve turning the knob clockwise . Do not force.

62408200

SAFETY INSTRUCTIONS

AVERTISSEMENT: Assurez vous de bien suivre les instructions données dans cette notice pour réduire au minimum le risque d'incendie ou d'explosion ou pour éviter tout dommage matériel, toute blessure ou la mort

- Ne pas entreposer ni utiliser d'essence ou ni d'autres vapeurs ou liquides inflammables à proximité de cette appareil ou de tout autre appareil.
- **QUE FAIRE SI VOUS SENTEZ UNE ODEUR DE GAZ:**
 - Ne pas tenter d'allumer l'appareil.
 - Ne touchez à aucun interrupteur, ne pas vous servir des téléphones se trouvant dans le bâtiment
 - Appelez immédiatement votre fournisseur de gas de puis un voisin. Suivez les instructions du fournisseur.
 - Si vous ne pouvez rejoindre le fournisseur, appelez le service des incendies
- L'installation et l'entretien doivent être assurés par un installateur ou un service d'entretien qualifié ou par le fournisseur de gaz.

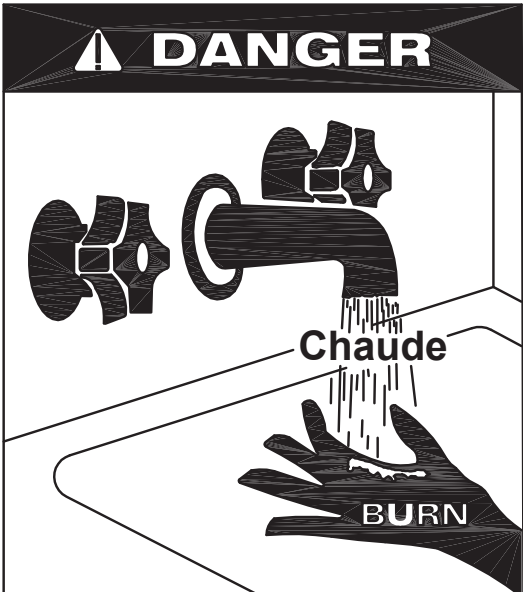

CHAUD

BURN

Un temperature de l'eau au dessus de 125°F (52°C), peut causer de graves brulures instantanément, ou la mort par échaudure.

Les enfants, les personnes handicapées ou âgées sont plus à risque d'être échaudées

Voir le manuel d'instruction avant de régler la température de l'eau sanitaire

Sentir la temperature de l'eau sanitaire avant un bain ou une douche

Limiteurs de temperature sont disponible voir le manuel

121110m0_d

SAFETY INSTRUCTIONS

POUR VOTRE SÉCURITÉ LISEZ AVANT D'ALLUMER

AVERTISSEMENT: Quiconque ne respecte pas à la lettre les instructions dans le présente notice risque de déclencher un incendie ou une explosion entraînant des dommages, des blessures ou la mort.

- A. Cet appareil ne comporte pas de veilleuse. Il est muni d'un dispositif d'allumage qui allume automatiquement le brûleur. Ne tentez pas d'allumer le brûleur manuellement.
- B. AVANT DE FAIRE FONCTIONNER, reniflez tout autour de l'appareil pour déceler une odeur de gaz. Reniflez près du plancher, car certains gaz sont plus lourds que l'air et peuvent s'accumuler au niveau du sol.
- QUE FAIRE SI VOUS SENTEZ UNE ODEUR DE GAZ:
- Ne pas tenter d'allumer d'appareil.
 - Ne touchez à aucun interrupteur; ne pas vous servir des téléphones se trouvant dans le bâtiment.
 - Appelez immédiatement votre fournisseur de gaz depuis un voisin. Suivez les instructions du fournisseur.
- Si vous ne pouvez rejoindre le fournisseur, appelez le service des incendies.
- C. Ne poussez ou tournez la manette d'admission du gaz qu'à la main; ne jamais utiliser d'outil. Si la manette reste coincée, ne pas tenter de la réparer; appelez un technicien qualifié. Le fait de forcer la manette ou de la réparer peut déclencher une explosion ou un incendie.
- D. N'utilisez pas cet appareil s'il a été plongé dans l'eau, même partiellement. Faites inspecter l'appareil par un technicien qualifié et remplacez toute partie du système de contrôle et toute commande qui ont été plongés dans l'eau.

INSTRUCTIONS DE MISE EN MARCHÉ

Entrée

gaz



Robinet gaz
montré en
position ouvert

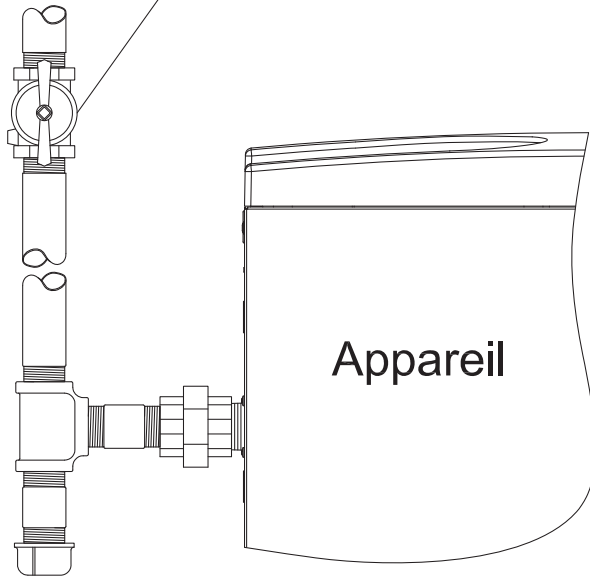

1. ARRÊTEZ! Lisez les instructions de sécurité sur la portion supérieure (à gauche) de cette étiquette.
2. Coupez l'alimentation électrique de l'appareil.
3. Positionner l'interrupteur sur zéro.
4. Cet appareil est muni d'un dispositif d'allumage qui allume automatiquement le brûleur. Ne tentez pas d'allumer le brûleur manuellement.
5. Fermer le robinet de l'admission du gaz tournant la manette dans le sens horaire
6. Attendre cinq (5) minutes pour laisser échapper tout le gaz. Reniflez tout autour de l'appareil, y compris près du plancher, pour déceler une odeur de gaz. Si vous sentez une odeur de gaz, ARRÊTEZ! Passez à l'étape B des instructions de sécurité sur la portion supérieure (à gauche) de cette étiquette. S'il n'y a pas d'odeur de gaz, passez à l'étape suivante.
7. Ouvrir le robinet de l'admission du gaz tournant la manette dans le sens antihoraire
8. Positionner l'interrupteur sur un (I).
9. Tourner un demande de eau chauffe suivante le manuel d'installation.
10. Si l'appareil ne se pas en marche, suivez les instructions intitulées "Comment couper l'admission de gaz de l'appareil" et appelez un technicien qualifié ou le fournisseur de gaz.

COMMENT COUPER L'ADMISSION DE GAZ DE L'APPAREIL

1. Coupez l'alimentation électrique de l'appareil s'il faut procéder à l'entretien.
2. Positionner l'interrupteur sur zéro (0).
3. Fermer le robinet de l'admission du gaz tournant la manette dans le sens horaire

62408???

62408200_fr

SAFETY INSTRUCTIONS

WARNING!!!

Installer: Read all instructions, including this manual, before installing. Perform steps in the order given.

User: This manual is for use only by a qualified heating installer. Refer to the User's Information Manual for your reference.

Maintenance: at least once a year the user must call a Qualified installer for routine maintenance.

Failure to comply with these provisions can cause a fire or explosion causing property damage, personal injury, or death.

WARNING!!!

If the information in this manual is not followed exactly, can result in a fire or explosion causing property damage, personal injury, or death.

WARNING!!!

Qualified installer: qualified installer is an individual with specific, technical training in space heating systems, domestic hot water systems, fuel gas systems and electrical systems. This individual must have the legally required qualifications. Failure to comply with these provisions can cause a fire or explosion causing property damage, personal injury, or death.

WARNING!!!

Installation and Alterations: Only a Qualified installer must carry out the installation and calibration of the heater. Never modify the heater or its flue gas carrying components in any way. This heater must be properly vented. Failure to follow these instructions could result in personal injury or death!

WARNING!!!

Flue gas/air intake: You are only permitted to operate this appliance with the combustion air/flue gas system that has been specifically designed and approved. Failure to follow these instructions could result in excessive levels of carbon monoxide which can cause severe personal injury or death!

WARNING!!!

Flue gas/air intake: Do not obstruct the air intake or vent pipe terminals. Failure to take proper precautions can result in excessive levels of carbon monoxide which can cause severe personal injury or death!

WARNING!!!

Flue gas/air intake: If heater installation is provided as replacement heater, DO NOT connect new heater venting to an existing vent system, if it is shared with other appliances. Failure to follow these instructions could result in excessive levels of carbon monoxide which can cause severe personal injury or death!

WARNING!!!

Flue gas/air intake terminals: Do not restrict or seal any air intake or outlet openings (terminals). Failure to follow these instructions could result in excessive levels of carbon monoxide which can cause severe personal injury or death!

WARNING!!!

Hazards and Your Safety - Hot Water Can Scald! Water temperature over 125°F (52°C) can cause severe burns instantly, or death from scalds. Children, the disabled, and the elderly are at highest risk of being scalded; see instruction manual before setting temperature at heater! Feel water before bathing or showering.

NOTICE! Local approval of the flue system and the condensate connection to the public sewer system may be required.

NOTICE! The local building regulations stipulating the installation rules at the time of installation.

CAUTION!!! Installation location:

The heater must be located in an area where leakage of the tank or connections will not result in damage to the area adjacent to the heater or to lower floors of the structure. When such locations cannot be avoided, it is recommended that a suitable drain pan, adequately drained, be installed under the heater. The pan must not restrict combustion air flow.

CAUTION!!! Installation location: The heater must not be installed on carpeting.

 **WARNING!!!** Defects: If you find any defects, you must inform the owner of the system of the defect and the associated hazard in writing. Failure to follow these instructions could result in excessive levels of carbon monoxide a fire or explosion which can cause severe personal injury or death!

 **CAUTION!!!** In the event of a breakdown and/or malfunction of the heater, turn off the unit and do not make any attempt to repair it. The heater must be serviced exclusively by a Qualified installer using original spare parts. Failure to comply with this requirement may compromise the safety of the unit.

 **WARNING!!!** When servicing heater, to avoid electric shock, disconnect electrical supply before performing maintenance. Failure to do so can cause severe personal injury or death.

SAFETY INSTRUCTIONS

WARNING!!!

When servicing heater, to avoid severe burns, allow heater to cool before performing maintenance. Failure to do so can cause severe personal injury or death.

WARNING!!!

Label all wires prior to disconnection when servicing controls. Wiring errors can cause improper and dangerous operation. Verify proper operation after servicing. Failure to follow these instructions can cause a fire or explosion causing property damage, personal injury, or death.

ATTENTION!!!

Au moment de l'entretien des commandes, étiquetez tous les fils avant de les débrancher. Des erreurs de câblage peuvent entraîner un fonctionnement inadéquat et dangereux. S'assurer que l'appareil fonctionne adéquatement une fois l'entretien terminé.

WARNING!!!

Correct Use:
This heater must only be used for the purpose for which it has been expressly designed: heating of water for closed circuit systems for central heating. Failure to follow these instructions could result in severe personal injury or death!

WARNING!!!

Should overheating occur or the gas supply fail to shut off, do not turn off or disconnect electrical supply to circulator. Instead, turn off the manual gas shut-off valve external to the appliance. Failure to follow these instructions could result in fire or explosion which can cause severe personal injury or death!

ATTENTION!!!

En cas de surchauffe ou si l'alimentation de gaz ne peut être coupée, ne pas couper ni débrancher l'alimentation électrique de la pompe. Fermer plutôt le robinet d'admission de gaz à l'extérieur de l'appareil

WARNING!!!

Do not use this appliance if any part has been under water. Immediately call a licensed authorized technician to inspect the appliance and to replace any part of the control system and any gas control, which has been under water. Failure to do so can cause severe personal injury or death.

ATTENTION!!!

N'utilisez pas cet appareil s'il a été plongé dans l'eau, même partiellement. Faites inspecter l'appareil par un technicien qualifié et remplacez toute partie du système de contrôle et toute commande qui ont été plongés dans l'eau.

WARNING!!!

Ensure the heater and its controls are protected from dripping or spraying water during normal operation or service. Failure to do so can cause severe personal injury or death.

NOTICE! When calling or writing about the heater – Please have the heater model and serial number from the heater rating plate.

NOTICE! Any claims for damage or shortage in shipment must be filed immediately against the transportation company by the consignee.

WARNING!!!

Only use the heater in the combinations and with the accessories and spares listed in this manual. Failure to do so can cause severe personal injury or death.

WARNING!!!

For safety and environmental reasons, the packing materials must be properly disposed of. Any replaced part or packaging should never be left within the reach of children. Failure to follow these instructions could result in severe personal injury or death!

CAUTION!!!

Do not use “homemade cures” or “heater patent medicines”. Serious damage to the heater, personnel, and/or property may result.

CAUTION!!!

Do not use petroleum-based cleaning or sealing compounds in the heater system. Gaskets and seals in the system may be damaged. This can result in substantial property damage.

NOTICE! The manufacturer declines all liability, contractual or otherwise (warranty included), for any damage to people, animals property or this same appliance, caused by:

- a) - incorrect installation;
- b) - failure to comply with this or any other instruction provided by the manufacturer;
- c) - failure to comply with the applicable local and/or national regulations in force;
- d) - incorrect use of this appliance
- e) - inadequate or incorrect service
- f) - inadequate or incorrect maintenance.

TABLE OF CONTENTS

SAFETY INSTRUCTIONS	2
TABLE OF CONTENTS	8
1 - CODE REQUIREMENTS	12
1.1 - Regulations and guidelines	12
2 - GENERAL INFORMATION	14
2.1 - Key to symbols used	14
2.2 - Manufactured by	14
2.3 - Description of models:	14
2.4 - Accessories included	14
3 - MAIN COMPONENTS	15
4 - FUNCTION OVERVIEW	26
4.1 - Intended use and functions	30
4.1.1 Intended use and functions of the IB boiler	30
4.1.2 Intended use and functions of the IW water heater	30
4.2 - Efficiency up to 98% (IB boiler only)	30
5 - INSTALLATION - Location	31
5.1 - Choosing the installation location	31
5.1.1 Prevent combustion air contamination	35
5.1.2 Location of an IB boiler	35
5.1.3 Location of an IW water heater	35
5.2 - Residential garage installation	36
5.3 - Closet and alcove installations	36
5.4 - Clearances for installation and servicing	36
5.5 - Clearances from combustible material	36
5.6 - Vent and combustion air piping	36
5.7 - Prevent combustion air contamination	36
6 - INSTALLATION - Mounting the heater	38
6.1 - Transporting the heater	38
6.2 - Mounting the heater	38
6.3 - Dimensions	39
7 - INSTALLATION - IB boiler water connection	42
7.1 - IB boiler water connections	42
7.1.1 Boiler water chemistry	42
7.1.2 Testing and maintenance of water quality	42
7.1.3 System flushing, treatment, and cleansing	43
7.1.4 Water Quality Maintenance and Warranty	43
7.1.5 Water Treatment Analysis and Scheduling	43
7.2 - Supply and return piping	44
7.2.1 - Near boiler heating piping components	45
7.2.2 - Relief valve	46
7.2.3 - Expansion Tank and Makeup Water	46
7.2.4 - Local boiler pump and CH pump	47
7.2.5 - Sizing heating system	47
7.2.6 - Domestic Hot Water system Piping when using an indirect water heater	47
8 - INSTALLATION - IW water connections	49
8.1 - IW Water heaters' water connections	49
8.2 - Hot and Cold water piping	49
8.2.1 - Near water heater piping components	49
8.2.2 - Temperature and pressure Relief valve	50
8.2.3 - Expansion Tank	51
8.2.4 - Circulator pump	51
8.2.5 - Sizing water system	51
8.2.6 - Anti-legionella	51
8.3 - Scalding	51
8.4 - Minimum and maximum water flow	52

TABLE OF CONTENTS

9 - INSTALLATION - Condensate disposal	54
9.1 - Condensate disposal.....	54
10 - INSTALLATION - Electrical connections	56
10.1 - Electrical connections: overview	56
10.1.1 - Connecting the power supply cable	57
10.1.2 - Room Thermostat wiring (IB Boiler only).....	57
10.1.3 - Installing the outdoor temperature sensor (IB Boiler only)	57
10.1.4 - Connection to an analog Vcc input.....	58
10.1.5 - Connection to a MODBUS protocol.....	58
10.1.6 - Connection to a LWCO device	58
10.1.7 - Alarm contact.....	58
10.2 - Connecting the IB boiler to an indirect water heater	59
10.2.1 Indirect water heater priority selection.....	59
10.3 - Connecting the IW water heater to a storage tank.....	59
10.4 - Connecting the heater in cascade.....	62
11 - INSTALLATION - Removing of an heater from a common venting system	64
11.1 - Removing of a heater from a common venting system	64
12 - INSTALLATION - CATEGORY IV: Vent and combustion air	65
12.1 - CATEGORY IV: Positive pressure condensing	65
12.2 - CATEGORY IV: Venting and air piping systems	65
12.3 - Minimum / Maximum allowable combustion air and vent piping lengths.....	67
12.4 - Install vent and combustion air piping	67
12.5 - Air inlet pipe materials:	69
12.5.1 - Sealing of PVC or CPVC air inlet pipe	69
12.6 - PVC/CPVC vent piping materials.....	70
12.6.1 - Installing PVC/CPVC vent and air piping	70
12.6.2 - PVC/CPVC air intake connection.....	71
12.6.3 - PVC/CPVC vent connection.....	71
12.7 - Stainless steel vent piping materials	72
12.7.1 - Stainless steel air intake connection	72
12.7.2 - Stainless steel vent connection	73
12.8 - Polypropylene vent piping materials	74
12.8.1 - Polypropylene air intake connection.....	75
12.8.2 - Polypropylene vent connection	75
12.9 - Single pipe vent (not sealed combustion)	76
12.9.1 - Determine location	77
12.10 - Sidewall termination - Two pipes.....	78
12.10.1 - Vent/air termination	78
12.10.2 - Determine location	78
12.10.3 - Prepare wall penetrations.....	80
12.10.4 - Termination and fittings	80
12.10.5 - Multiple vent/air terminations.....	80
12.11 - Sidewall termination – Concentric vent	81
12.11.1 - Description and usage.....	81
12.11.2 - Sidewall termination installation	81
12.11.3 - Multiventing sidewall terminations	82
12.12 - Vertical termination - Two pipes	83
12.12.1 - Determine location	83
12.12.2 - Prepare roof penetrations.....	83
12.12.3 - Termination and fittings	83
12.12.4 - Multiple vent/air terminations.....	84
12.13 - Vertical termination – Concentric vent.....	85
12.13.1 - Description and usage.....	85
12.13.2 - Determine location	85
12.13.3 - Vertical termination installation.....	85
12.13.4 - Multiventing vertical terminations	86

TABLE OF CONTENTS

13 - INSTALLATION - CATEGORY II: Vent and combustion air	87
13.1 - CAT II: Negative pressure condensing	87
13.2 - CAT II: Adapter and increaser	87
13.3 - Condensing vent option: CATEGORY II:	88
14 - INSTALLATION - Gas supply	90
14.1 - Gas supply piping	90
14.2 - Pipe sizing for natural gas	91
14.3 - Propane Gas	91
14.4 - Check inlet gas supply pressure	92
14.5 - Operating at high altitudes	92
14.6 - Convert a heater model 199 from Natural Gas to Propane gas or viceversa	93
14.7 - Convert a heater model 399, 500, 750 or 1000 from Natural Gas to Propane gas or viceversa	95
15 - START-UP	96
15.1 - Operating	96
15.1.1 - User instructions	96
15.1.2 - Filling the condensate and neutralizing box	96
15.1.3 - Filling the heating system on a IB boiler	96
15.2 - General warnings concerning gas supply	96
15.3 - Confirming the heater's gas type	97
15.4 - Gas type conversion	97
15.5 - Start-up	97
15.5.1 - Start-up of the IB boiler	97
15.5.2 - Start-up of the IW water heater	97
15.6 - Ignition control testing	97
15.7 - Gas supply pressure checking	98
15.8 - Checking and adjusting CO2 levels	99
15.8.1 - Checking CO2 level on units model 199	99
15.8.2 - Checking CO2 level on units model 399 up to 1000	99
15.9 - Check the capacity input	100
15.10 - Minimum water flow	100
16 - USE	101
16.1 - Check water pressure	102
16.1.1 - Check water pressure on IB boiler	102
16.1.2 - Check water pressure on IW water heater	102
16.2 - Overview	102
16.3 - Displays	102
16.4 - Start-up procedure	102
16.5 - IW supply water temperature adjustment	102
16.6 - IB - Indirect water heater temperature adjustment	103
16.7 - IB - Heating temperature adjustment	103
16.8 - IB - Outdoor reset adjustment	103
16.8.1 - Outdoor reset applications	103
16.8.2 - Outdoor reset: setting parameters	103
16.9 - Delays, alarms and protective actions	105
16.10 - Circulator pump protection	105
16.11 - Heater's Freeze protection	105
16.12 - Display in energy saver mode	105
16.13 - "Users' menu"	106
16.14 - "Installer's menu"	107
16.15 - Diagnostic	108
16.16 - Diagnostic: Lockouts "Loc"	109
16.17 - Diagnostic: Blocking errors "Err"	111
16.18 - Flue blocked pressure switch	112
16.19 - Shuts heater down	112
16.20 - How to clean the appliance jacket	112

TABLE OF CONTENTS

17 - MAINTENANCE	113
17.1 - Care and maintenance.....	113
17.1.1 - Address reported problems.....	114
17.1.2 - Check all piping for gas leaks.....	114
17.1.3 - Verify flue and air lines in good condition and sealed tight;.....	114
17.1.4 - Check system water pressure/system piping/expansion tank;.....	114
17.1.5 - Check control settings.....	114
17.1.6 - Check ignition and flame sense electrodes.....	114
17.1.7 - Check wiring and connections.....	114
17.1.8 - Perform performance verification.....	114
17.1.9 - Flame inspection.....	115
17.1.10 - Check flame signal.....	115
17.1.11 - Check relief valve.....	115
17.1.12 - Check heater area.....	115
17.1.13 - Check pressure gauge.....	115
17.1.14 - Check vent piping.....	115
17.1.15 - Check air piping.....	115
17.1.16 - Check condensate drain system.....	115
17.1.17 - Check heater piping (gas and water).....	115
17.1.18 - Shut heater down.....	116
17.1.19 - Test low water cutoff (if installed).....	116
17.1.20 - Reset button (low water cutoff).....	116
17.2 - Removing the casing.....	116
17.3 - Cleaning the burner and primary heat exchanger, flue gas side.....	117
17.3.1 - Thermal insulations.....	120
17.4 - Correct positioning of the ignition and flame detection electrodes.....	121
17.5 - Clean the air filter.....	121
17.6 - Condensate trap and neutralizing box maintenance and cleaning.....	122
17.7 - Connection of the display to other burners.....	123
17.8 - How to move a control board.....	124
17.9 - Draining the water from the heater.....	126
17.10 - Water and flue temperature sensor.....	127
17.11 - Outdoor temperature sensor.....	127
17.12 - 199 model wiring diagram.....	128
17.13 - 399 to 1000 models wiring diagram.....	130
18 - TECHNICAL DATA	134
19 - SPARE PARTS	136
20 - READ OUT FLOW CHART	158
21 - FACTORY MENU	159
22 - SEQUENCE OF OPERATION for BOILER	162
23 - SEQUENCE OF OPERATION for WATER HEATER	163

1 - CODE REQUIREMENTS

1.1 - Regulations and guidelines

- The installation must conform to the requirements of the authority having jurisdiction or, in the absence of such requirements, to:

- the latest edition of the ***National Fuel Gas Code, ANSI Z223.1/NFPA 54*** and or ***CAN/CSA B149.1, Natural Gas and Propane Installation Code.***

- the latest edition of the ***National Electric Code ANSI/NFPA 70*** and or ***Canadian Electrical Code Part 1 CSA C22.1.***

- Where required by the authority having jurisdiction, the installation must conform to the Standard for ***Controls and Safety Devices for Automatically Fired Boilers, ANSI/ASME CSD-1.***

NOTICE!

Install CO detectors per local regulations.

NOTICE!

IB Boiler version meets the safety and other performance requirements as specified in ANSI Z21.13 standard.

NOTICE!

IW Water heater version meets the safety and other performance requirements as specified in ANSI Z21.10.3 standard.

NOTICE!

IB boiler version: per DOE mandate, the operator control incorporates an automatic means (outdoor reset) of adjusting the boiler water temperature for hot water heating. The boiler must not operate without the automatic means enabled.

NOTICE!

IB boiler version: in accordance with Section 325 (f)(3) of the energy policy and conservation Act, this boiler is equipped with a feature that saves energy by reducing the boiler water temperature has the heating load decreases.

1 - CODE REQUIREMENTS

1.2- Commonwealth of Massachusetts Installation Requirements

In the Commonwealth of Massachusetts, the installation must be performed by a licensed plumber or gas fitter.

⚠ WARNING!!! Improper venting can result in excessive levels of carbon monoxide which can cause severe personal injury or death!

(a) For all side wall horizontally vented gas fueled equipment installed in every dwelling, building or structure used in whole or in part for residential purposes, including those owned or operated by the commonwealth and where the side wall exhaust vent termination is less than seven (7) feet above finished grade, in the area of the venting, including but not limited to decks and porches, the following requirements shall be satisfied:

1. INSTALLATION OF CARBON MONOXIDE DETECTORS. At the time of installation of the side wall horizontal vented gas fueled equipment, the installing plumber or gasfitter shall observe that a hard wired carbon monoxide detector with an alarm and battery back-up is installed on the floor level where the gas equipment is to be installed. In addition, the installing plumber or gasfitter shall observe that a battery operated or hard wired carbon monoxide detector with an alarm is installed on each additional level of the dwelling, building or structure served by the side wall horizontal vented gas fueled equipment. It shall be the responsibility of the property owner to secure the services of qualified licensed professionals for the installation of hard wired carbon monoxide detectors.
 - a. In the event that the side wall horizontally vented gas fueled equipment is installed in a crawl space or an attic, the hard wired carbon monoxide detector with alarm and battery back-up may be installed on the next adjacent floor level.
 - b. In the event that the requirements of this subdivision can not be met at the time of completion of installation, the

owner shall have a period of thirty (30) days to comply with the above requirements; provided, however, that during said thirty (30) day period, a battery operated carbon monoxide detector with an alarm shall be installed.

2. APPROVED CARBON MONOXIDE DETECTORS. Each carbon monoxide detector as required in accordance with the above provisions shall comply with NFPA 720 and be ANSI/UL 2034 listed and IAS certified.
3. SIGNAGE. A metal or plastic identification plate shall be permanently mounted to the exterior of the building at a minimum height of eight (8) feet above grade directly in line with the exhaust vent terminal for the horizontally vented gas fueled heating appliance or equipment. The sign shall read, in print size no less than one-half (1/2) inch in size, "**GAS VENT DIRECTLY BELOW. KEEP CLEAR OF ALL OBSTRUCTIONS**".
4. INSPECTION. The state or local gas inspector of the side wall horizontally vented gas fueled equipment shall not approve the installation unless, upon inspection, the inspector observes carbon monoxide detectors and signage installed in accordance with the provisions of 248 CMR 5.08(2)(a)1 through 4.

(b) Exemptions

The following equipment is exempt from 248 CMR 5.08(2)(a) 1 through 4:

1. The equipment listed in Chapter 10 entitled "Equipment Not Required To Be Vented" in the most current edition of NFPA 54 as adopted by the Board; and
2. Product Approved side wall horizontally vented gas fueled equipment installed in a room or structure separate from the dwelling, building or structure used in whole or in part for residential purposes.

(c) MANUFACTURER REQUIREMENTS - GAS EQUIPMENT - VENTING SYSTEM PROVIDED.

When the manufacturer of Product Approved side wall horizontally vented gas equipment provides a venting system design or venting system components with the equipment, the instructions provided by the manufacturer for installation of the equipment and the venting system shall include:

1. Detailed instructions for the installation of the venting system design or the venting system components; and

2. A complete parts list for the venting system design or venting system.

(d) MANUFACTURER REQUIREMENTS - GAS EQUIPMENT - VENTING SYSTEM NOT PROVIDED.

When the manufacturer of a Product Approved side wall horizontally vented gas fueled equipment does not provide the parts for venting the flue gases, but identifies "special venting systems", the following requirements shall be satisfied by the manufacturer:

1. The referenced "special venting system" instructions shall be included with the appliance or equipment installation instructions; and
2. The "special venting systems" shall be Product Approved by the Board, and the instructions for that system shall include a parts list and detailed installation instructions.

(e) A copy of all installation instructions for all Product Approved side wall horizontally vented gas fueled equipment, all venting instructions, all parts lists for venting instructions, and/or all venting design instructions shall remain with the appliance or equipment at the completion of the installation.

2 - GENERAL INFORMATION

2.1 - Key to symbols used

⚠ WARNING!!! Failure to follow these indications can causing an explosion, fire, extensive property damage, severe personal injury or death!

CAUTION!!! Failure to observe this indication may compromise the smooth running of the appliance or cause serious damage to individuals, animals or property.

NOTICE! Indicates special instructions on installation, operation, or maintenance that are important but not related to personal injury or property damage.

 Important indication symbol

XX XXXX ABC

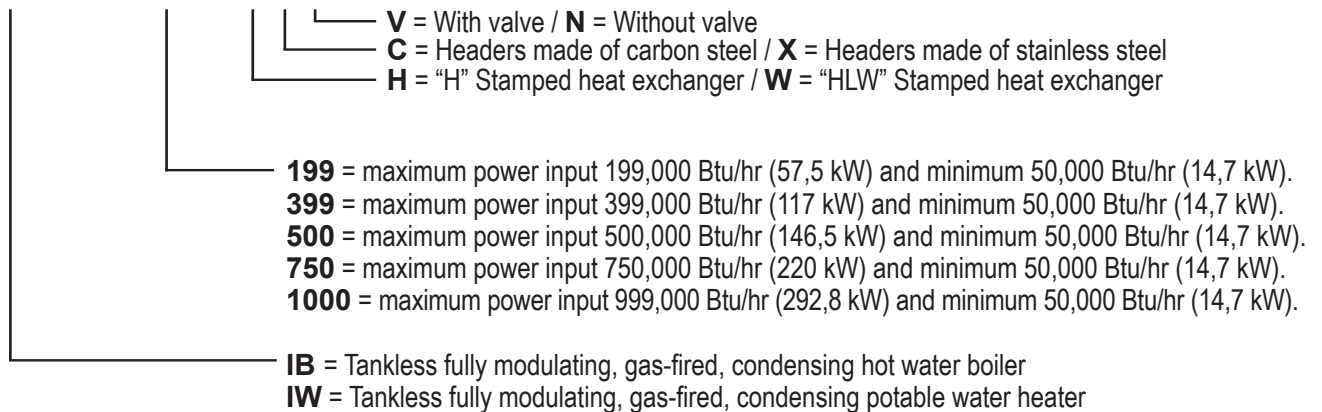





2.2 - Manufactured by

RBI WATER HEATER
 7555 Tranmere Drive
 Mississauga, Ontario L5S 1L4
 Canada
 Phone: (905) 670-5888
 Fax: (905) 670-5782
 www.rbiwaterheaters.com

2.3 - Description of models:

2.4 - Accessories included

The appliance is equipped with the following accessories:

Quantity No.	Description	P/N	Figure
No. 1	NAT TO LP GAS CONVERSION KIT 199 TO 1000	62630209	
No. 1	SENSOR 10K D6X45 L=2500 T	62110071	
No. 1	OUTDOOR SENSOR (NOT PRESENT ON WATER HEATER VERSIONS)	62110067	
No. 4	ADJUSTABLE FOOT	60805006	
No. 1	NEUTRALIZING LIMESTONE 10KG	62801022	

3 - MAIN COMPONENTS

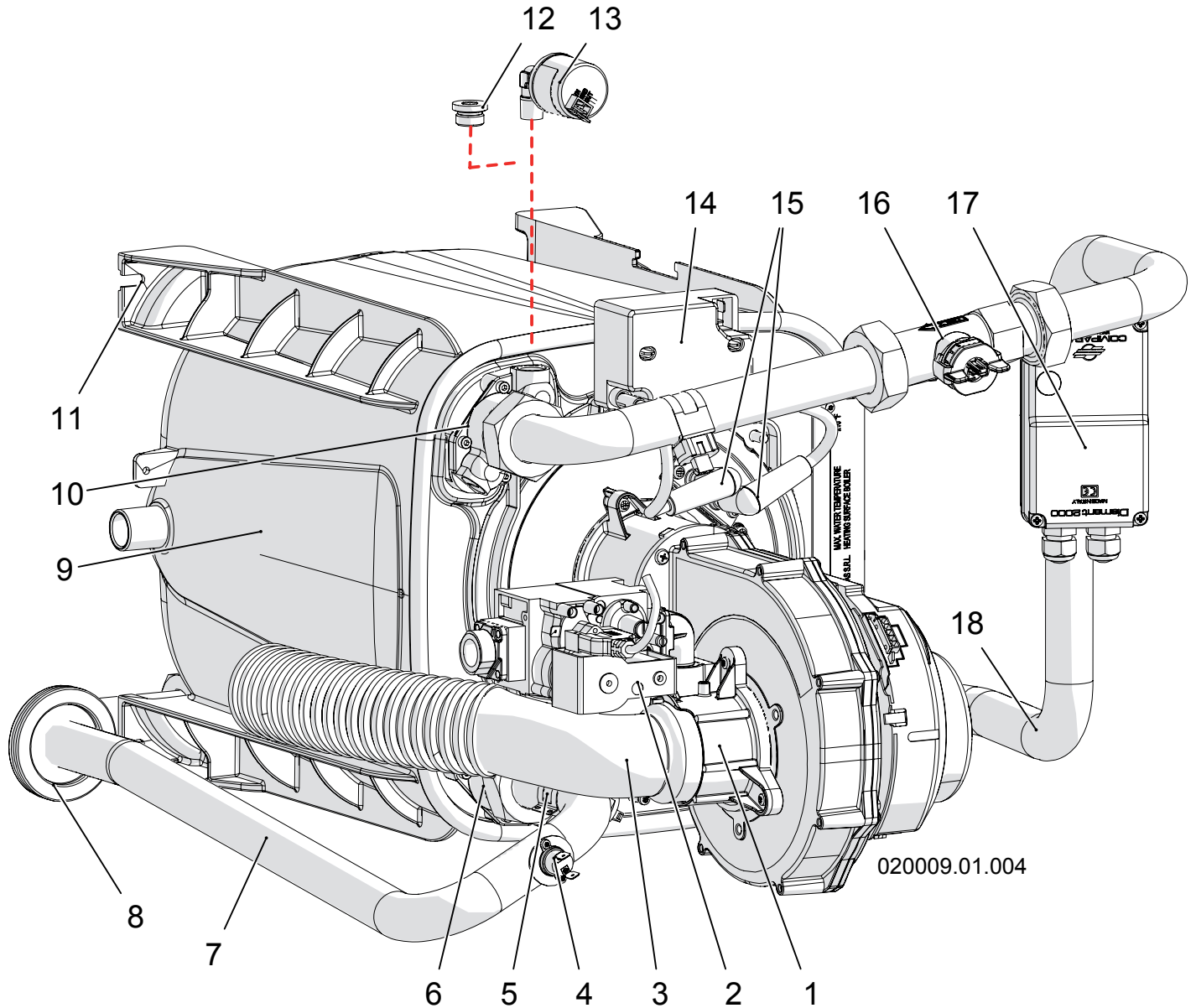

- | | |
|--|---|
| 1 - Air / gas mixing device | 10 - Burner unit return connection |
| 2 - Gas valve | 11 - Support arrangement |
| 3 - Air intake silencer | 12 - Plug (present on BURNER 2, 3 and 4 if any) |
| 4 - High limit temperature safety switch (UL 353 listed) | 13 - Water pressure sensor (present on Burner 1 only) |
| 5 - Burner unit supply temperature sensor (par. 1001) | 14 - Spark generator |
| 6 - Burner unit supply connection | 15 - Ignitors covers |
| 7 - Burner unit supply pipe | 16 - Water flow sensor (par. 1062) |
| 8 - Gasket | 17 - Motorized valve (optional) |
| 9 - Unit heat exchanger | 18 - Return pipe |

Figure 3-1 Burner unit main components

3 - MAIN COMPONENTS

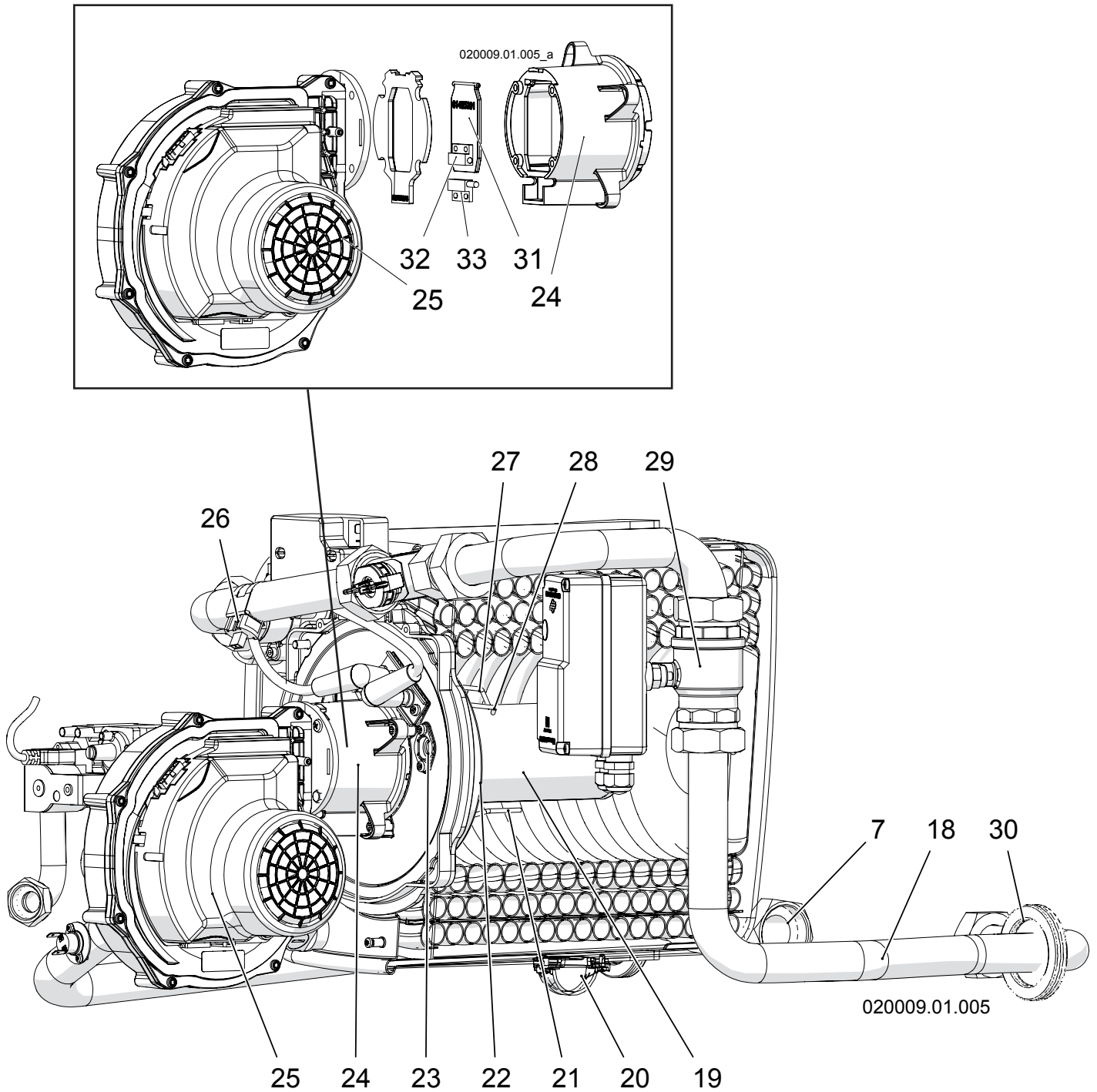

- 19 - Burner surface
- 20 - Burner unit condensate discharge
- 21 - Detection electrode
- 22 - Thermal insulation
- 23 - Sight glass
- 24 - Raccord fan-burner
- 25 - Modulating Fan
- 26 - Return temperature sensor (par. 1007)

- 27 - Left ignition electrode
- 28 - Right ignition electrode
- 29 - Motorized valve body (optional)
- 30 - Gasket
- 31 - Flapper valve
- 32 - Flapper magnet
- 33 - Flapper sensor

Figure 3-2 Burner unit main components

3 - MAIN COMPONENTS

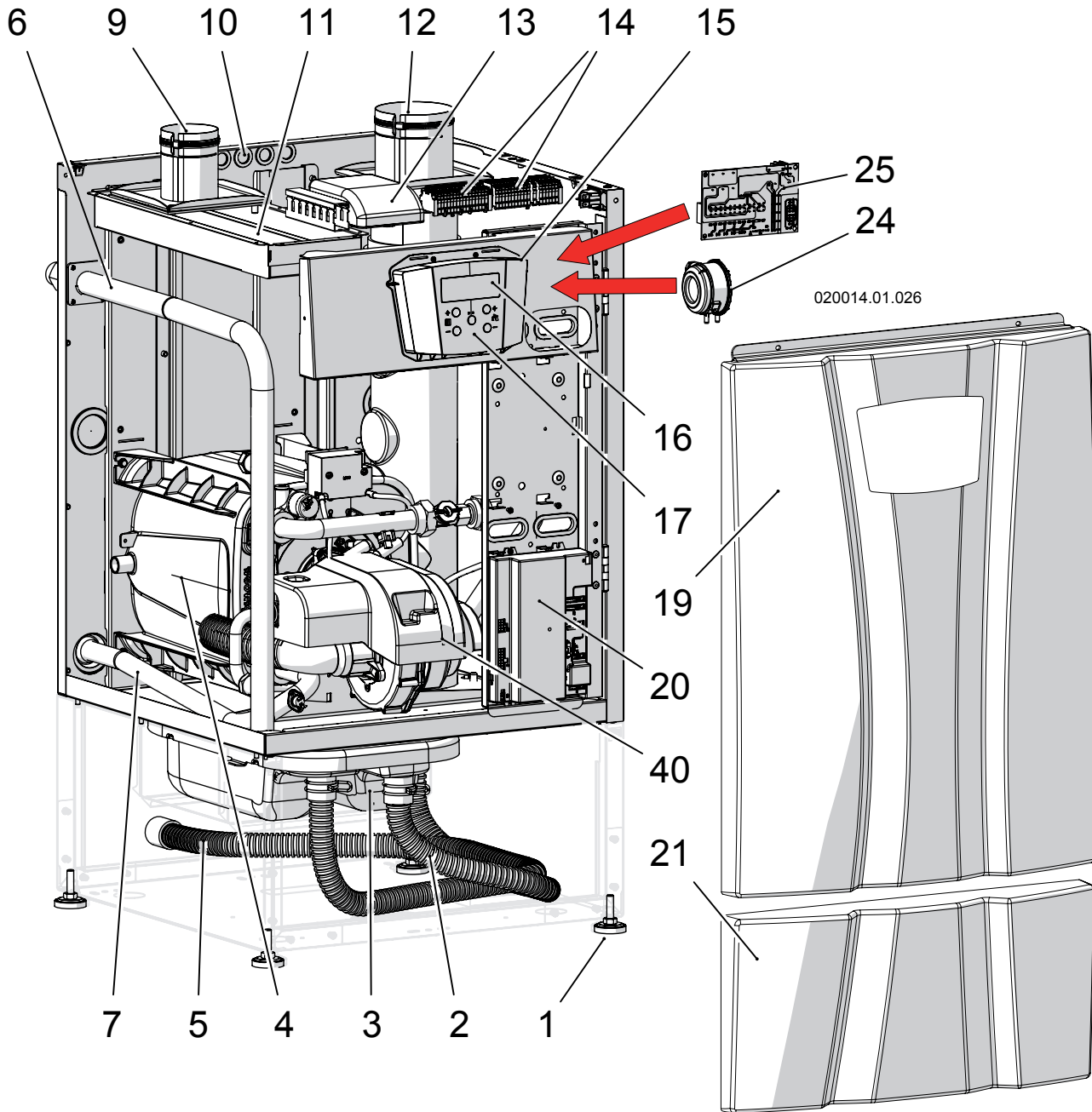

- 1 - Leveling feet
- 2 - Condensate hose that coming from heater's flue exhaust
- 3 - Condensate neutralizer box
- 4 - Heat exchanger
- 5 - Condensate discharge hose
- 6 - Gas inlet pipe
- 7 - Supply pipe
- 9 - Air inlet connection
- 10 - Electrical cable passages
- 11 - Air filter

- 12 - Flue exhaust connection
- 13 - 885IF board (Optional)
- 14 - Electrical terminals (Junction box)
- 15 - Control panel cover
- 16 - Display
- 17 - Control keys
- 19 - Front cover
- 20 - Control board
- 21 - Bottom front cover

Figure 3-3 Main components for models 199

3 - MAIN COMPONENTS

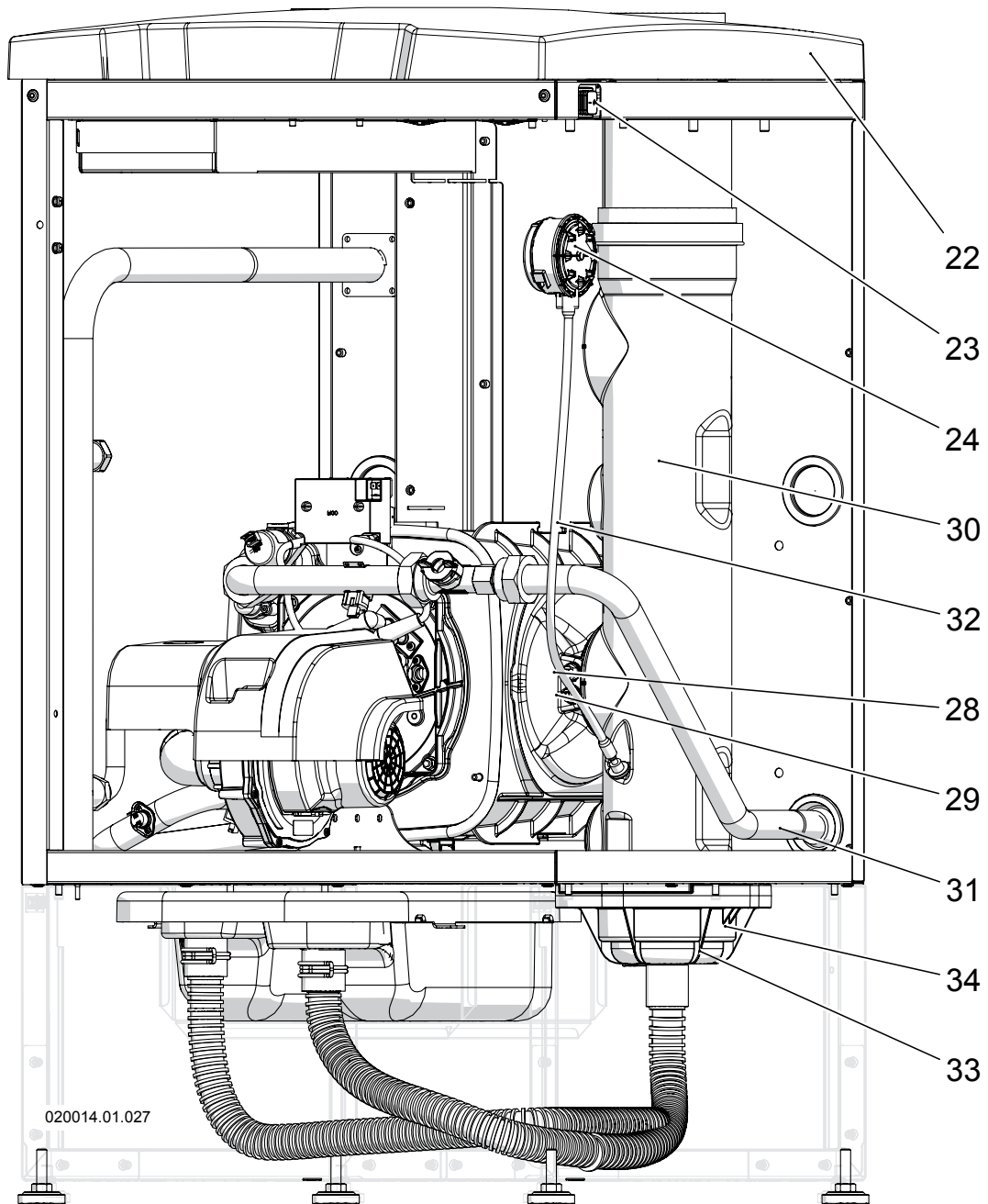

- 22 - Top cover
- 23 - Main electrical switch
- 24 - Flue blocked pressure switch
- 25 - Electrical board
- 28 - Flue gas temperature sensor (Blue color connector) (1006)

- 29 - High limit flue gas temperature fuse (Red color connector)
- 30 - Flue gas exhaust manifold
- 31 - Water Return connection
- 32 - Flue blocked pressure switch pipe connection
- 33 - Condensate blocked drain magnetic switch

Figure 3-4 Main components for model 199

3 - MAIN COMPONENTS

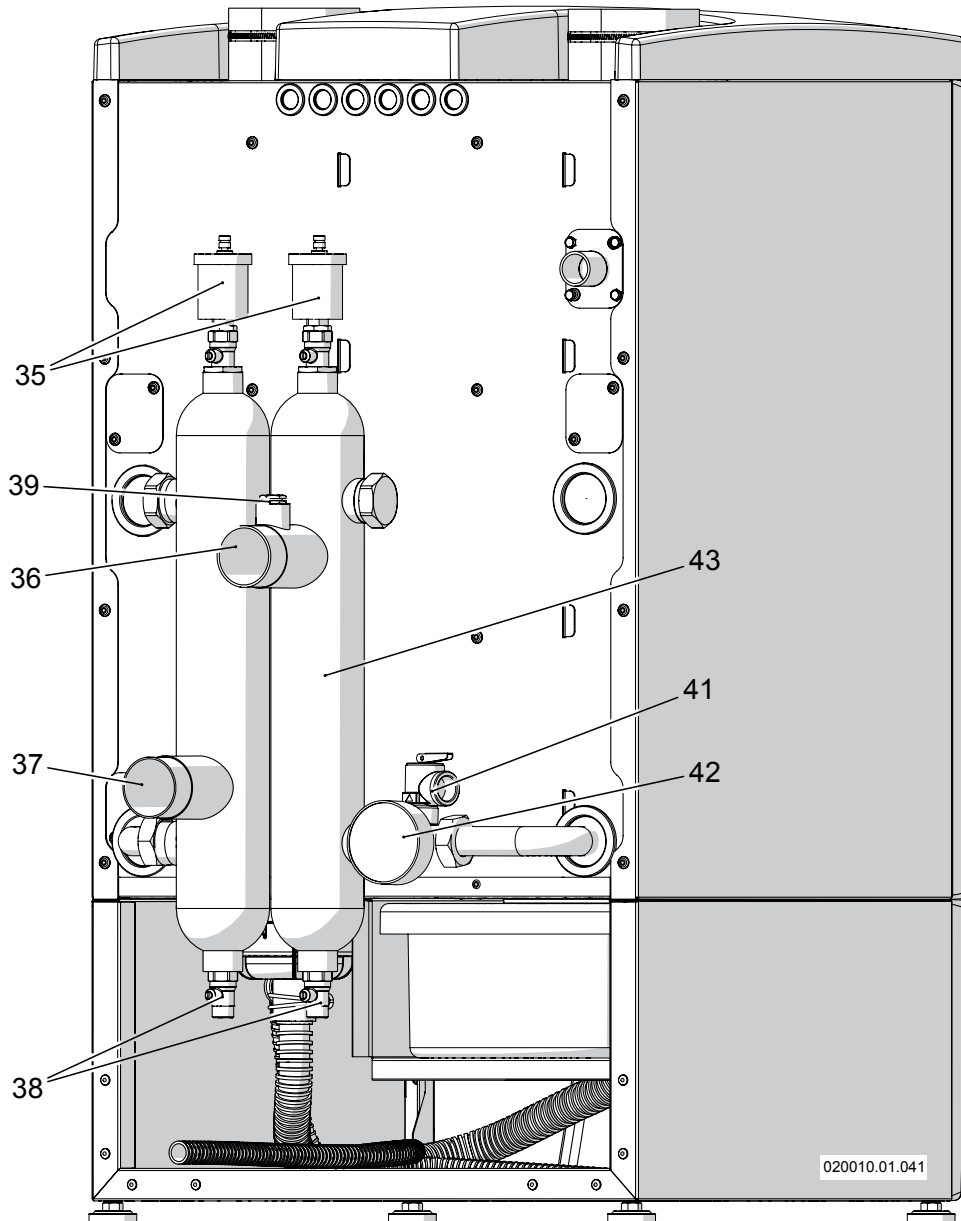

020010.01.041

- 34 - Flue gas manifold cap
- 35 - Automatic air vent
- 36 - Water Supply connection
- 37 - Water Return connection
- 38 - Draining valves
- 39 - Header temperature sensor (1102)
- 40 - Fan cover

- 41 - Safety relief valve (P-T safety relief valve on IW water heater)
- 42 - Pressure and temperature gauge
- 43 - Supply and return Headers

Figure 3-5 Main components for model 199

3 - MAIN COMPONENTS

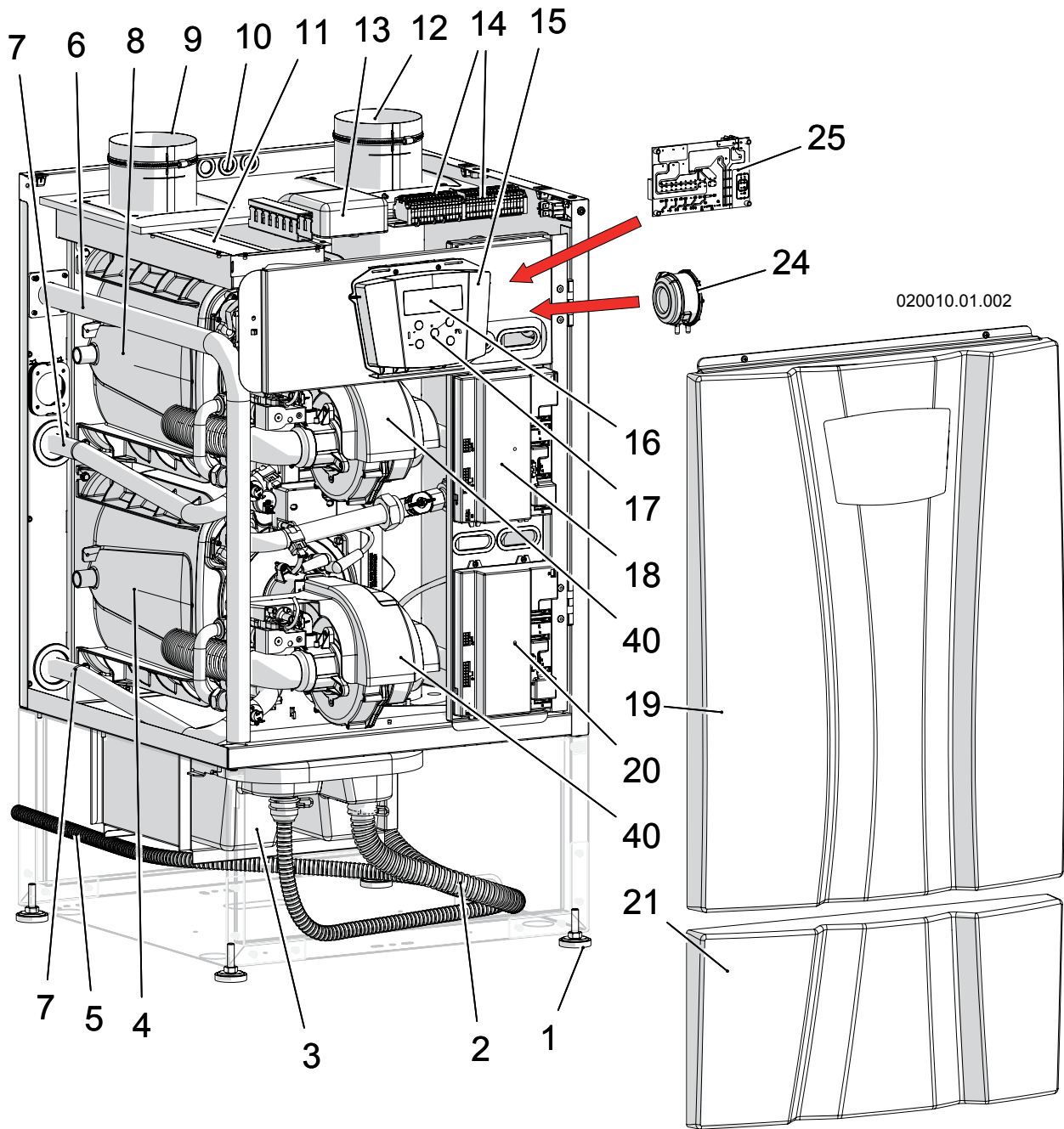

- 1 - Leveling feet
- 2 - Condensate hose coming from heater's flue exhaust
- 3 - Condensate neutralizer box
- 4 - Heat exchanger
- 5 - Condensate discharge hose
- 6 - Gas inlet pipe
- 7 - Water Supply pipe
- 8 - Heat exchanger
- 9 - Air inlet connection
- 10 - Electrical cable passages
- 11 - Air filter

- 12 - Flue exhaust connection
- 13 - 885IF board (Optional on model 399)
- 14 - Electrical terminals
- 15 - Control panel cover
- 16 - Display
- 17 - Control keys
- 18 - "Burner 2" power control board
- 19 - Front cover
- 20 - "Burner 1" (Master) power control board
- 21 - Bottom front cover

Figure 3-6 Main components for models 399 and 500

3 - MAIN COMPONENTS

BURNER 2

BURNER 1 (Master)

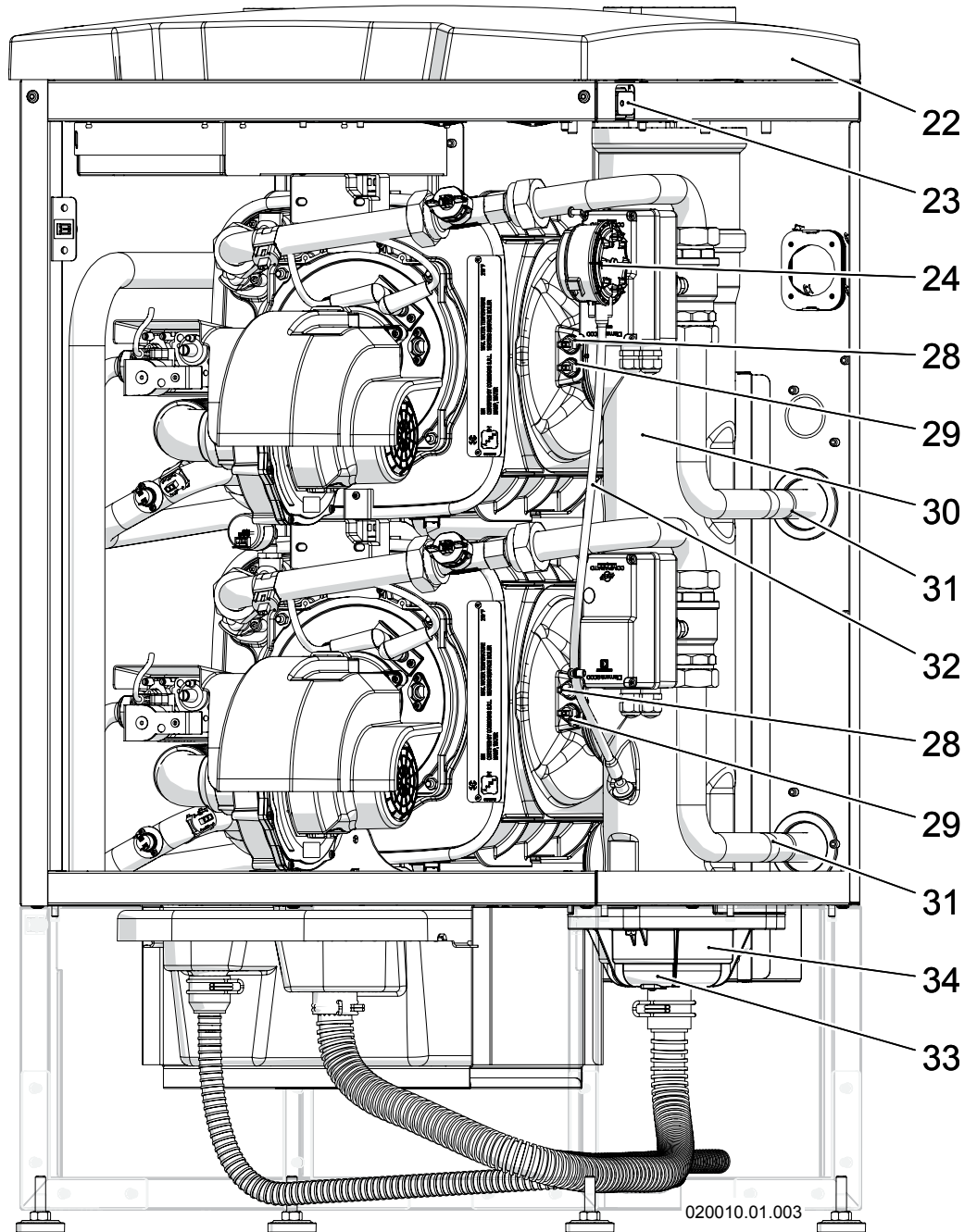

- 22 - Top cover
- 23 - Main electrical switch
- 24 - Flue blocked pressure switch
- 25 - Electrical Board
- 28 - Flue gas temperature sensor (Blue color connector) (1006)
- 29 - High limit flue gas temperature fuse (Red color connector)
- 30 - Flue gas exhaust manifold
- 31 - Water Return pipe

- 32 - Flue blocked pressure switch pipe
- 33 - Condensate blocked drain magnetic switch
- 34 - Flue gas manifold cap

Figure 3-7 Main components for models 399 and 500

3 - MAIN COMPONENTS

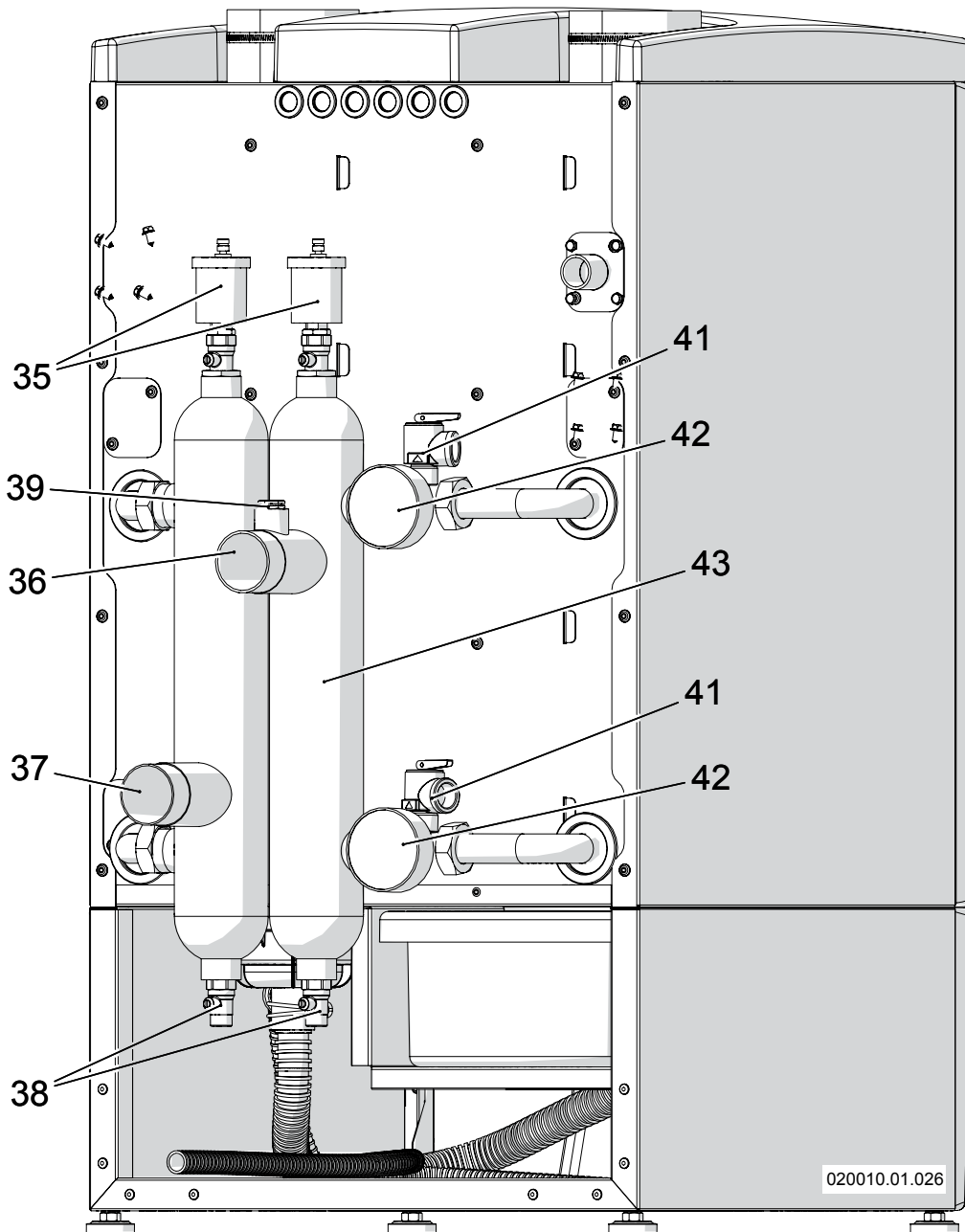

- 35 - Automatic air vent
- 36 - Water Supply connection
- 37 - Water Return connection
- 38 - Draining valves
- 39 - Header temperature sensor (1102)
- 41 - Safety relief valve (P-T safety relief valve on IW water heater)
- 42 - Pressure and temperature gauge
- 43 - Supply and return headers

Figure 3-8 Main components for models 399 and 500

3 - MAIN COMPONENTS

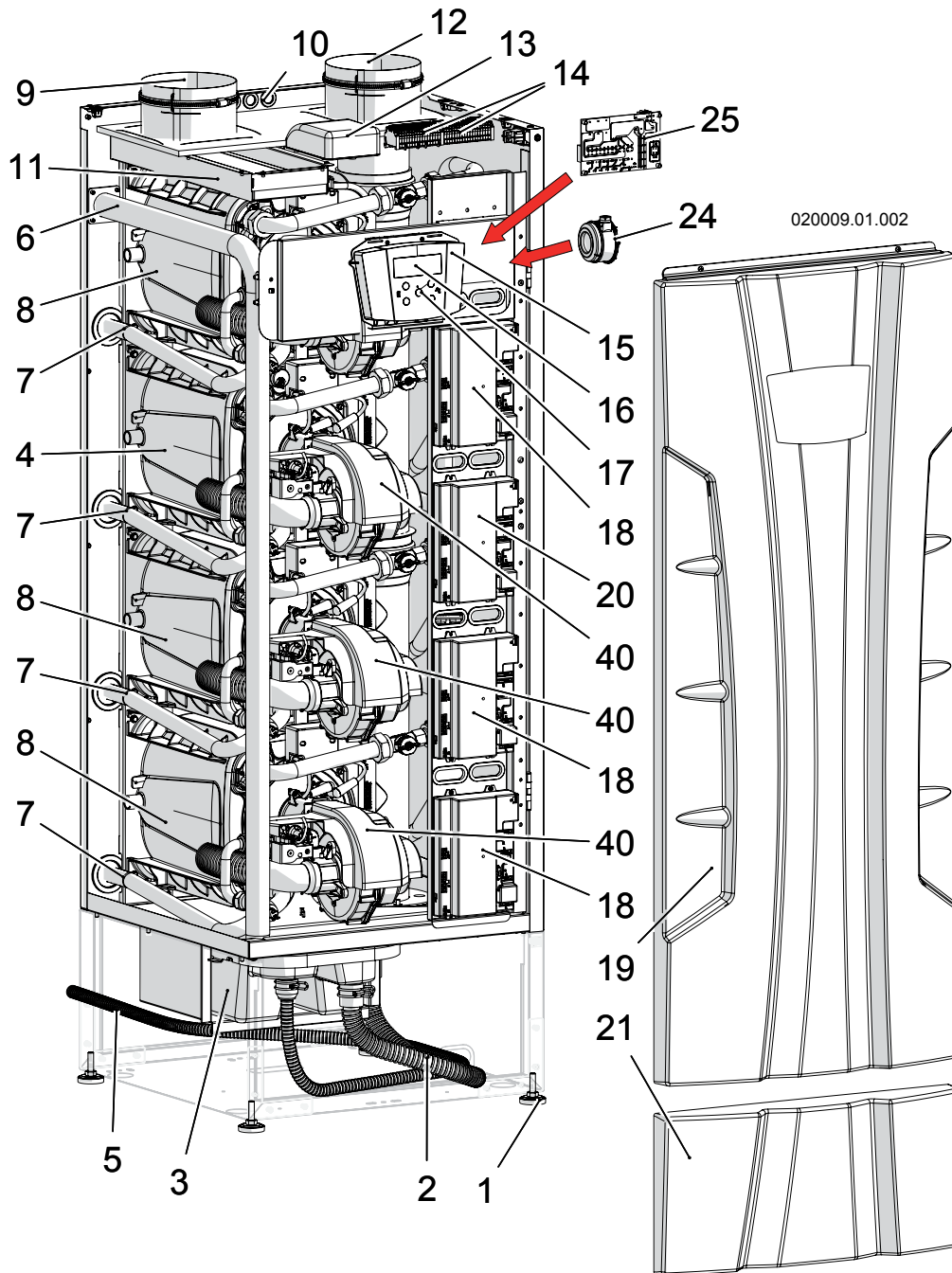

- 1 - Leveling feet
- 2 - Condensate hose coming from heater's flue exhaust
- 3 - Condensate neutralizer box
- 4 - Heat exchanger of the "Burner 1" (Master)
- 5 - Condensate discharge hose
- 6 - Gas inlet pipe
- 7 - Water Supply pipes
- 8 - Heat exchangers (the highest heat exchanger is not present on model 750)
- 9 - Air inlet connection
- 10 - Electrical cable passages
- 11 - Air filter
- 12 - Flue exhaust connection
- 13 - 885IF board

- 14 - Electrical terminals
- 15 - Control panel cover
- 16 - Display
- 17 - Control keys
- 18 - Power control boards (the highest power control board is not present on model 750)
- 19 - Front cover
- 20 - "Burner 1" (Master) power control board
- 21 - Bottom front cover
- 24 - Flue blocked pressure switch
- 25 - Electrical control board
- 40 - Fan cover

Figure 3-9 Main components for models 750 and 1000

3 - MAIN COMPONENTS

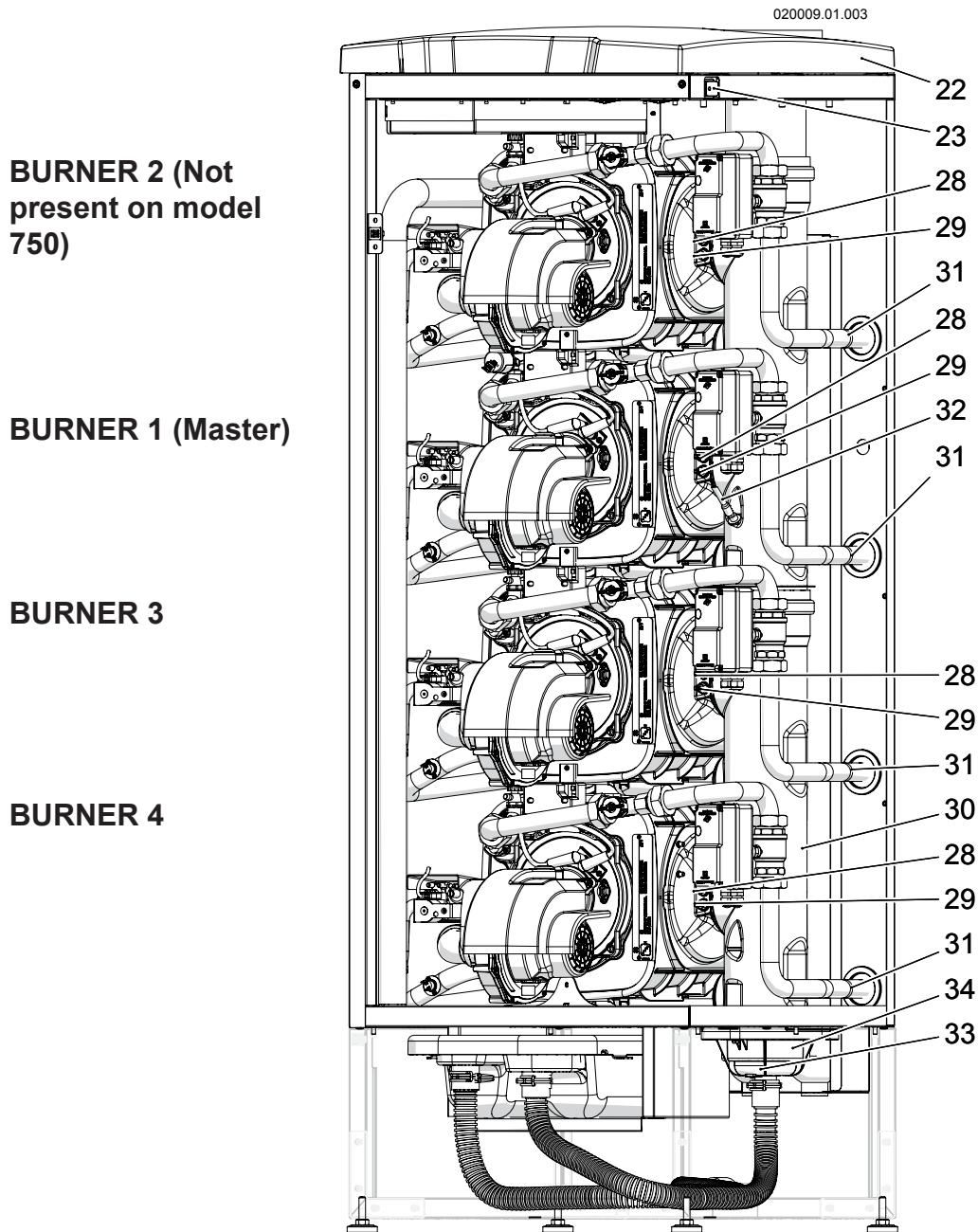

- 22 - Top cover
- 23 - Main electrical switch
- 28 - Flue gas temperature sensor (Blue color connector) (1006)
- 29 - High limit flue gas temperature fuse (Red color connector)
- 30 - Flue gas exhaust manifold
- 31 - Water Return connection
- 32 - Flue blocked pressure switch pipe connection
- 33 - Condensate blocked drain magnetic switch
- 34 - Flue gas manifold cap

Figure 3-10 Main components for models 750 and 1000

3 - MAIN COMPONENTS

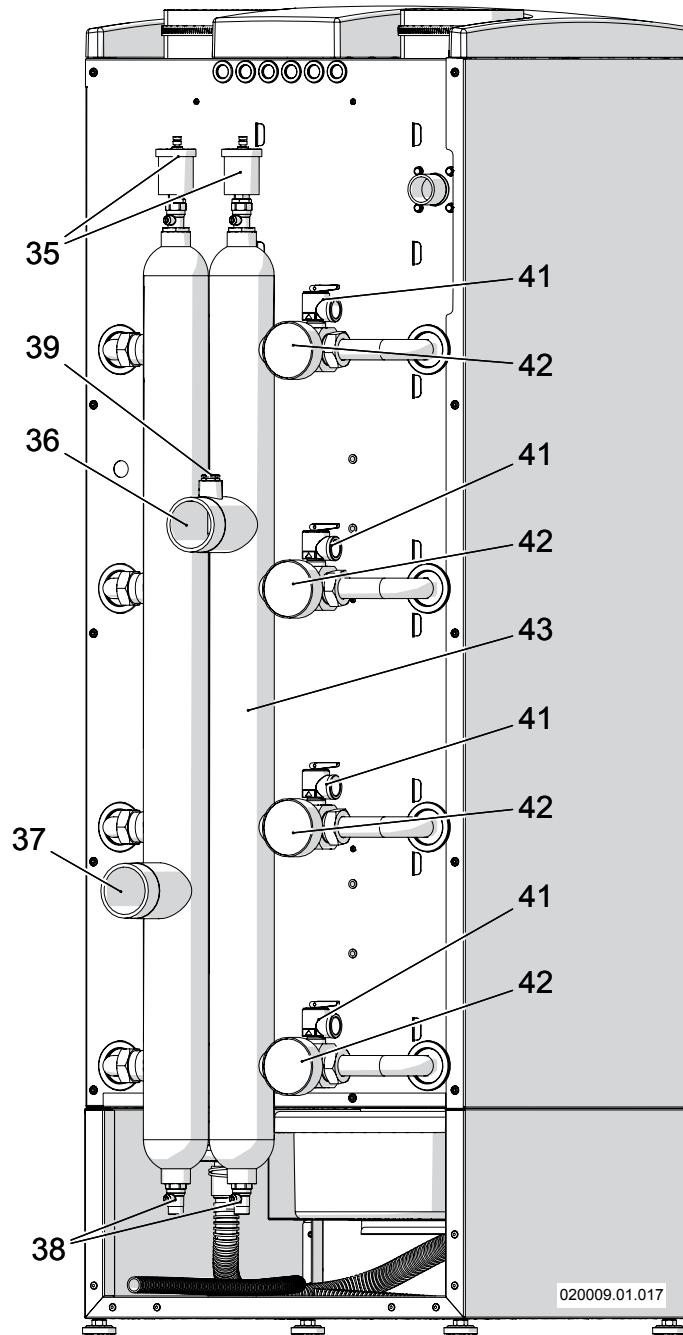

- 35 - Automatic air vent
- 36 - Water supply connection
- 37 - Water return connection
- 38 - Drain valves
- 39 - Header temperature sensor (1102)
- 41 - Safety Relief valve (P-T relief valve on IW water heater)
- 42 - Pressure and temperature gauge
- 43 - Supply and return headers

Figure 3-11 Main components for models 750 and 1000

4 - FUNCTION OVERVIEW

Key to figures 4-1:

- 1 - Air inlet
- 2 - Flue exhaust
- 4 - Sealing chamber
- 6 - High limit supply temperature switch
- 7 - Supply temperature sensor
- 8 - Water pressure sensor
- 9 - Flue gas temperature sensor
- 10 - High limit flue gas temperature fuse
- 12 - Premix burner
- 13 - Ignition electrodes
- 14 - ignitor
- 15 - Return temperature sensor
- 16 - Modulating PWM fan
- 17 - Back flue preventer
- 20 - Gas valve
- 22 - Detection electrode
- 24 - CRV Stainless steel heat exchanger
- 25 - Water supply
- 26 - Water return
- 27 - Gas inlet
- 28 - Blocked flue pressure switch
- 29 - Condensing blocked drain switch
- 30 - Condensing drain
- 31 - Condensate Siphon
- 36 - Condensate neutralizer box
- 37 - ASME Safety relief valve (Boiler)
P-T relief valve (Water Heater)
- 51 - Pressure/temperature gauge

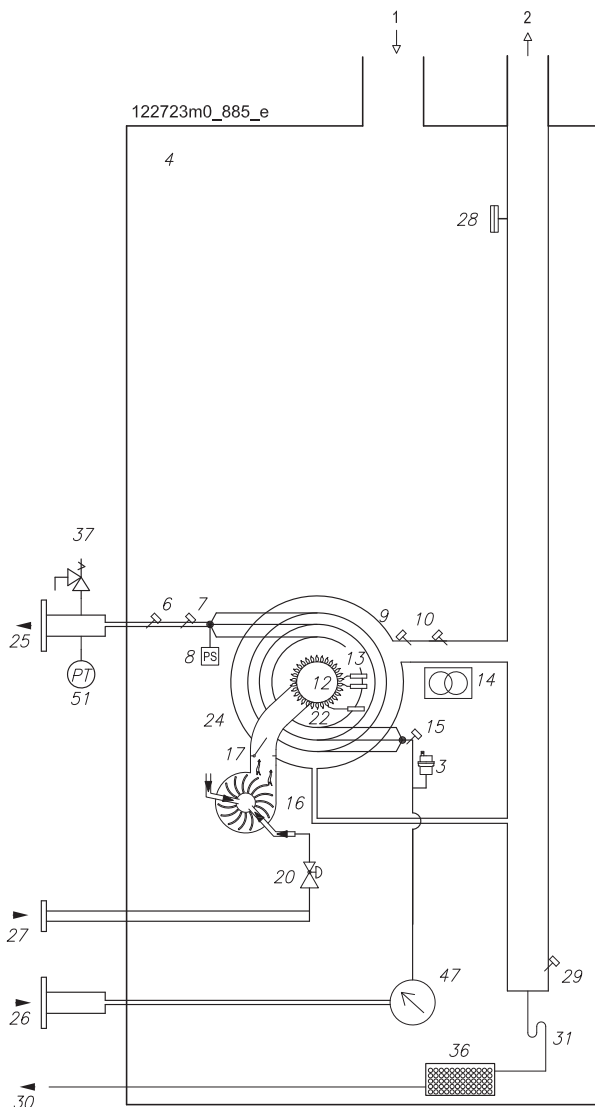

Figure 4-1 - Hydronic functional schematic for model 199

4 - FUNCTION OVERVIEW

Key to figures 4-2:

- 1 - Air inlet
- 2 - Flue exhaust
- 3 - Automatic air vent
- 4 - Sealing chamber
- 6 - High limit supply temperature switch
- 7 - Supply temperature sensor
- 8 - Water pressure sensor
- 9 - Flue gas temperature sensor
- 10 - High limit flue gas temperature fuse
- 12 - Premix burner
- 13 - Ignition electrodes
- 14 - ignitor
- 15 - Return temperature sensor
- 16 - Modulating PWM fan
- 17 - Back flue preventer
- 20 - Gas valve
- 22 - Detection electrode
- 23 - Supply and return manifolds
- 24 - CRV Stainless steel heat exchanger
- 25 - Water supply
- 26 - Water return
- 27 - Gas inlet
- 28 - Blocked flue pressure switch
- 29 - Condensing blocked drain switch
- 30 - Condensing drain
- 31 - Condensate Siphon
- 33 - Header temperature sensor
- 36 - Condensate neutralizer box
- 37 - ASME Safety relief valve (Boiler)
P-T relief valve (Water Heater)
- 47 - Water Flow meter
- 48 - Motorized valve (optional)
- 50 - Drain valve
- 51 - Pressure/temperature gauge

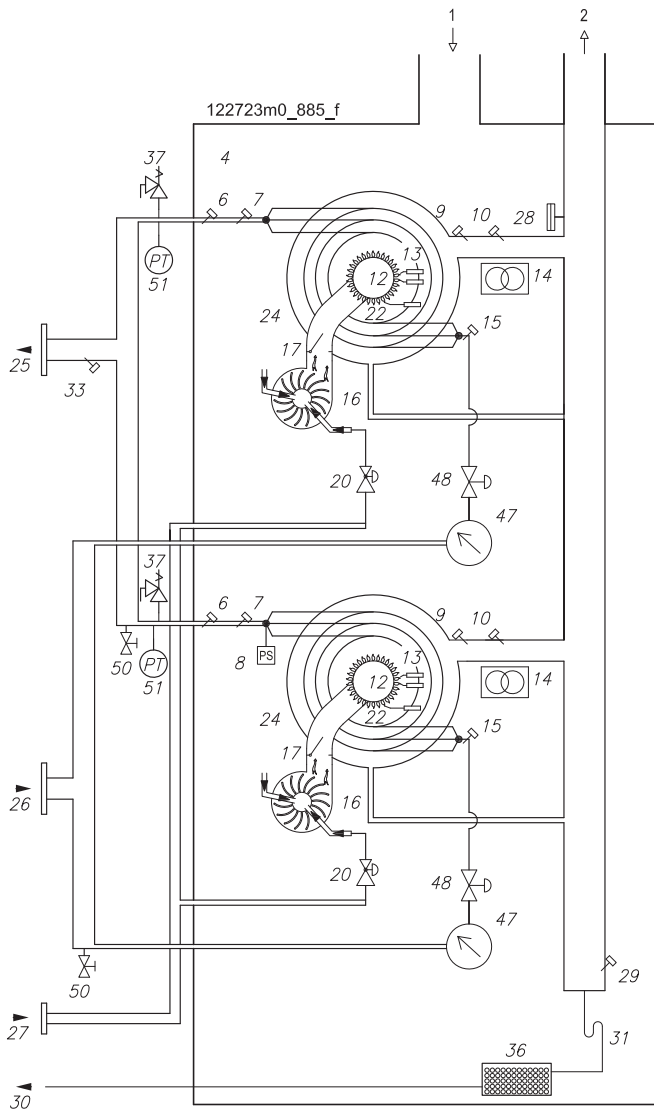
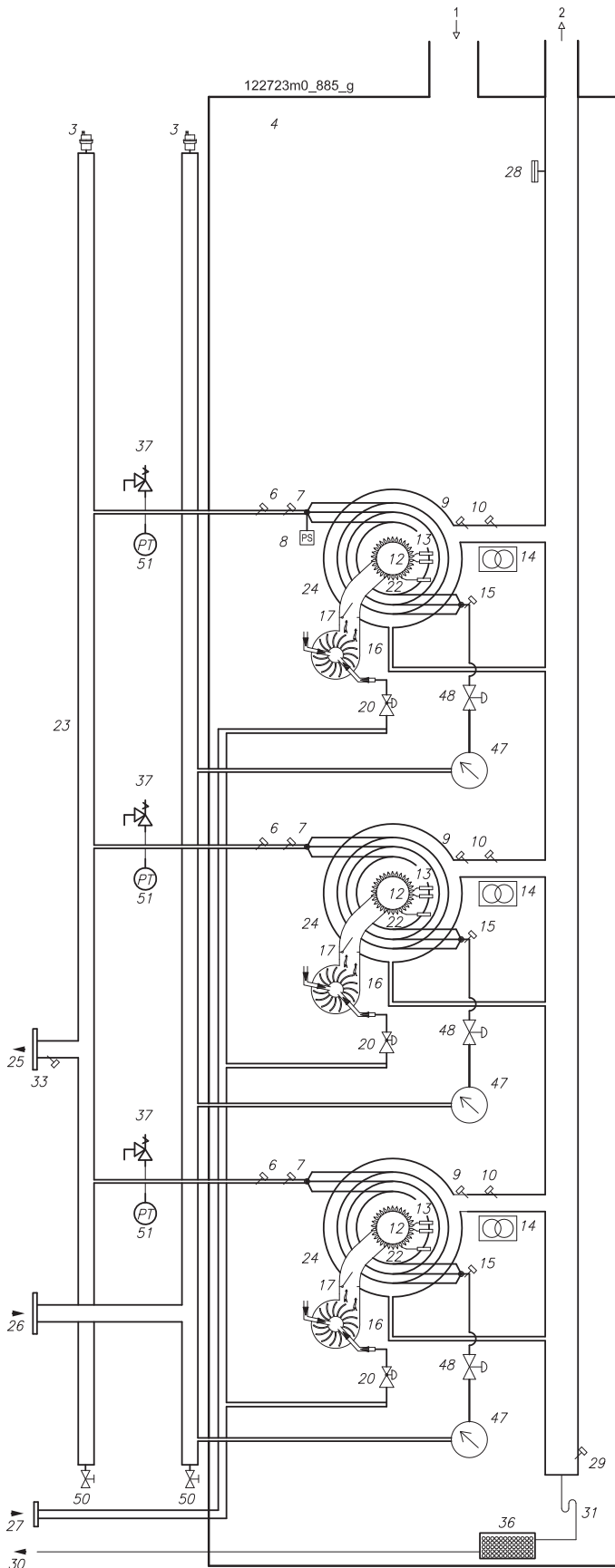

Figure 4-2 - Hydronic functional schematic for models 399 and 500

4 - FUNCTION OVERVIEW



Key to figures 4-3

- 1 - Air inlet
- 2 - Flue exhaust
- 3 - Automatic air vent
- 4 - Sealing chamber
- 6 - High limit supply temperature switch
- 7 - Supply temperature sensor
- 8 - Water pressure sensor
- 9 - Flue gas temperature sensor
- 10 - High limit flue gas temperature fuse
- 12 - Premix burner
- 13 - Ignition electrodes
- 14 - ignitor
- 15 - Return temperature sensor
- 16 - Modulating PWM fan
- 17 - Back flue preventer
- 20 - Gas valve
- 22 - Detection electrode
- 23 - Supply and return headers
- 24 - CRV Stainless steel heat exchanger
- 25 - Water supply
- 26 - Water return
- 27 - Gas inlet
- 28 - Blocked flue pressure switch
- 29 - Condensing blocked drain switch
- 30 - Condensing drain
- 31 - Condensate Siphon
- 33 - Header temperature sensor
- 36 - Condensate neutralizer box
- 37 - ASME Safety relief valve (Boiler)
P-T relief valve (Water Heater)
- 47 - Flow meter
- 48 - Motorized valve (optional)
- 50 - Drain valve
- 51 - Pressure/temperature gauge

Figure 4-3 - Hydronic functional schematic for model 750

4 - FUNCTION OVERVIEW

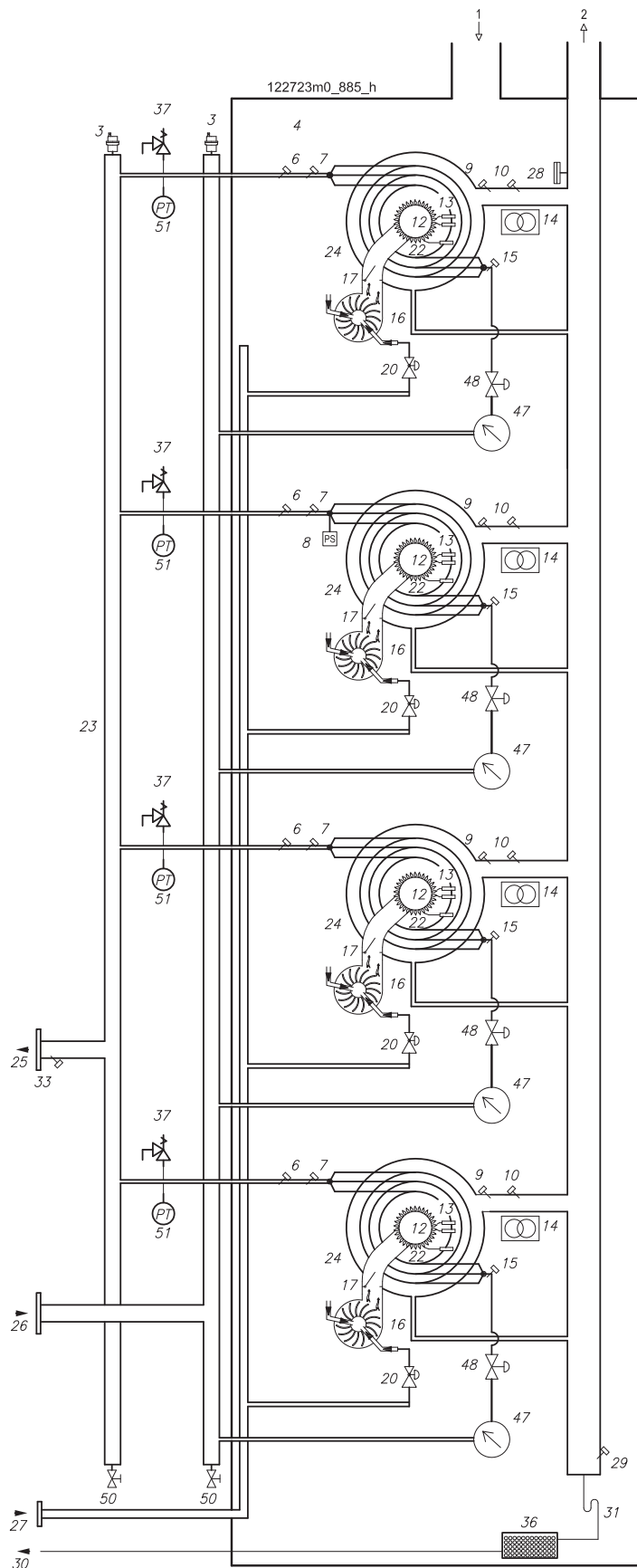

Key to figures 4-4:

- 1 - Air inlet
- 2 - Flue exhaust
- 3 - Automatic air vent
- 4 - Sealing chamber
- 6 - High limit supply temperature switch
- 7 - Supply temperature sensor
- 8 - Water pressure sensor
- 9 - Flue gas temperature sensor
- 10 - High limit flue gas temperature fuse
- 12 - Premix burner
- 13 - Ignition electrodes
- 14 - ignitor
- 15 - Return temperature sensor
- 16 - Modulating PWM fan
- 17 - Back flue preventer
- 20 - Gas valve
- 22 - Detection electrode
- 23 - Supply and return headers
- 24 - CRV Stainless steel heat exchanger
- 25 - Water supply
- 26 - Water return
- 27 - Gas inlet
- 28 - Blocked flue pressure switch
- 29 - Condensing blocked drain switch
- 30 - Condensing drain
- 31 - Condensate Siphon
- 33 - Header temperature sensor
- 36 - Condensate neutralizer box
- 37 - ASME Safety relief valve (Boiler)
P-T relief valve (Water Heater)
- 47 - Flow meter
- 48 - Motorized valve (optional)
- 50 - Drain valve
- 51 - Pressure/temperature gauge

Figure 4-4 - Hydronic functional schematic for model 1000

4 - FUNCTION OVERVIEW

4.1 - Intended use and functions

The heater is designed to supply the maximum heat output at 180°F with a minimum delta T of 35°F. If you want 180°F supply and lower delta T, you should downrate the capacity using parameter 2002 on each burner. If you don't downrate the capacity the relative burner will go into Err 60.

If the heater is used for space heating respect the minimum water flow as per section 18. If the heater is used to warm domestic hot water, respect the minimum flow as per section 8.4

4.1.1 Intended use and functions of the IB boiler

The boiler version, is designed to be used for central heating system for civil uses. Any other use is prohibited.

The maximum output heat is always guaranteed for the production of domestic hot water since it is given priority over space heating demands.

Follow the specific procedure in Section 16.6 for the adjustment of the domestic hot water temperature.

The boiler version can be installed with a Direct Venting system or with a one pipe vent system and getting combustion air from room.

The quality of the system water is very

important. Poor water quality can damage heating systems and boilers due to scale formation and corrosion.

The boiler version can be connected to an indirect storage tank for the production of domestic hot water (Section 7.2.6).

Using the boiler version, you can create a system with heating elements functioning at temperature range between 68°F (20°C) and 180°F (82°C) can be configured.

When connecting the boiler version to the heating system the installer must consider the head loss of the boiler (see Figure 7-2) and the head loss of the heating system to size adequate pumps. Boiler can be connected to a room thermostat, Section 10.1.2.

An outdoor air temperature sensor must also be connected to the boiler for an outdoor reset supply temperature control for maximum fuel efficiency and comfort (see Section 10.1.3). In this configuration the room thermostat will compensate by adjusting the room temperature.

The room temperature compensation can be of an ON /OFF type. For further information on the outdoor-air reset, refer to Section 16.8.

☞ The boiler must be connected to an heating system with compatible specifications, performance and power rating.

4.1.2 Intended use and functions of the IW water heater

The water heater version, is designed to warm domestic water (potable) for civil uses. Any other use is prohibited.

The water heater can be installed with a Direct Venting system or with a one pipe vent system and getting combustion air from room.

The quality of the system water is very important. Poor water quality can damage the water heater due to scale formation and corrosion.

This water heater must be connected to a storage water heater for the production of domestic hot water (Section 8).

When connecting the water heater to the storage water heater size the correct circulator pump. The installer must consider:

- the head loss of the water heater (see Figure 7-2);
- the head loss of the piping system;
- the head loss of the storage water heater;
- the water hardness be compatible with the minimum water velocity;

The heater must be connected to a domestic hot water supply with compatible specifications, performance and power rating.

4.2 - Efficiency up to 98% (IB boiler only)

Section applicable to boiler version only. When the outdoor reset is activated (an outside sensor is connected), the boiler always works at the maximum efficiency (see Section 16.8). It will automatically change the supply temperature in relation with the outdoor temperature (Outdoor reset).

The graph in Figure 4-5 shows an example on how it can work.

This graph represents an installation where the supply and return temperatures are 139°F (60°C) and 115°F (46°C) respectively, and the outside temperature is 23°F (-5°C). The outdoor reset drives the boiler, to progressively reduce the supply temperature and thereby optimize the efficiency. It changes from 87% when outside is -10°F (-23°C), to 94.8% when outside is 23°F (-5°C) and up to 98% when the outside temperature rises up to 67°F (20°C).

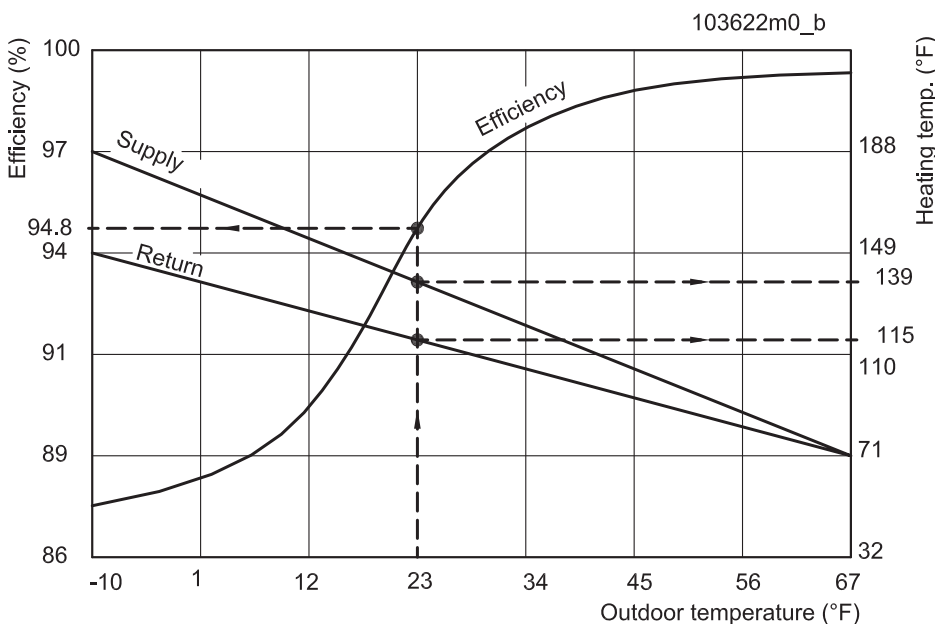

Figure 4-5 Outdoor reset control to optimize the efficiency

5 - INSTALLATION - Location

5.1 - Choosing the installation location

! WARNING!!! Do not store any flammable materials or liquids in the immediate vicinity of the heater. A fire or explosion can result, causing severe personal injury, death, or substantial property damage.

! WARNING!!! Do not install the heater on carpeting. Fire can result, causing severe personal injury, death, or substantial property damage.

! WARNING!!! Provisions for combustion air and ventilation of the heater room are always required, regardless whether the combustion air is taken from the outside (Direct Vent, sealed combustion) or inside (room air for combustion). Failure to comply with this provision could result in excessive levels of carbon monoxide or a fire, which can result in severe personal injury or death!

! WARNING!!! Insufficient ventilation of the heater room can lead to high air temperatures. Failure to comply with this provision could result in excessive levels of carbon monoxide or a fire, which can result in severe personal injury or death!

! WARNING!!! Make sure that intake and exhaust openings are sufficiently sized and no reduction or closure of openings takes place. When the problem is not resolved, do not operate the heater. Please note these restrictions and its dangers to the operator of the heater. Failure to comply with these provisions could result in severe personal injury, death, or substantial property damage.

! WARNING!!! LIQUEFIED PETROLEUM (L.P.) PROPANE GAS-FIRED HEATER LOCATION REQUIRES SPECIAL ATTENTION: 1994 UNIFORM MECHANICAL CODE, section 304.6: "LPG Appliances. Liquefied petroleum gas-burning appliances shall not be installed in a pit, basement or similar location where heavier-than-air-gas might collect. Appliances so fueled shall not be installed in an abovegrade under-floor space or basement unless such location is provided with an approved means for removal of unburned gas." Failure to comply with this provision could result in and explosion that can cause severe personal injury, death, or substantial property damage.

CAUTION!!! This heater is not designed for direct outdoor installation. If installed outside of the structure, it must be sheltered so it is protected from rain, wind, sun and frost. NEVER place this heater in a location that would subject it to temperatures at or near freezing or temperature that exceed 100°F (38°C). Failure to properly locate this heater can result in premature failure.

CAUTION!!! This heater must be installed in a location so that any water leaking from the heater or piping connections or relief valve openings will not cause damage to the area surrounding the unit or any lower floors in the structure.

CAUTION!!! When installed in a room with thin floor, resonating noise may occur. Install noise reducing parts if required.

CAUTION!!! Do not allow too much dust to collect on the heater.

Maintain minimum specified clearances for adequate operation. All installations must allow sufficient space for servicing the vent connections, water pipe connections, piping and other auxiliary equipment, as well as the appliance. The clearance labels on each appliance note the same service and combustible clearance requirements as shown on section 5.4 and 5.5.

Multiple appliances may be installed in a modular heater installation.

Consult the venting section of this manual for specific installation instructions for the appropriate type of venting system that you will be using. Direct vent and vent/air venting systems require installation with **Category IV** flue pipe, sealed air inlet pipe, and air inlet caps, which must meet the manufacturer's specifications.

Combustion and ventilation air requirements for appliances drawing air from the equipment room.

Provisions for combustion and ventilation air must be in accordance with air for combustion and ventilation, of the latest edition of the National Fuel Gas Code, ANSI Z223.1, in Canada, the latest edition of CGA Standard B149 Installation Code for Gas Burning Appliances end Equipment, or applicable provisions of the local building codes.

5 - INSTALLATION - Location

The equipment room MUST be provided with properly sized openings to assure adequate combustion air and proper ventilation.

1. If air is taken directly from outside the building with no duct, provide two permanent openings to the equipment room (see Fig. 5-1)

(a) Combustion air opening, with a minimum free area of one square inch per 4000 Btu/hr input (5.5 cm² per kW). This opening must be located within 12" (30 cm) of the bottom of the enclosure.

(b) Ventilation air opening, with a minimum free area of one square inch per 4000 Btu/hr input (5.5 cm² per kW). This opening must be located within 12" (30 cm) of the top of the enclosure.

2. If combustion and ventilation air is taken from the outdoors using a duct to deliver the air to the equipment room, each of the two openings should be sized based on a minimum free area of one square inch per 2000 Btu/hr (11 cm² per kW) of input (see Fig. 5-2).

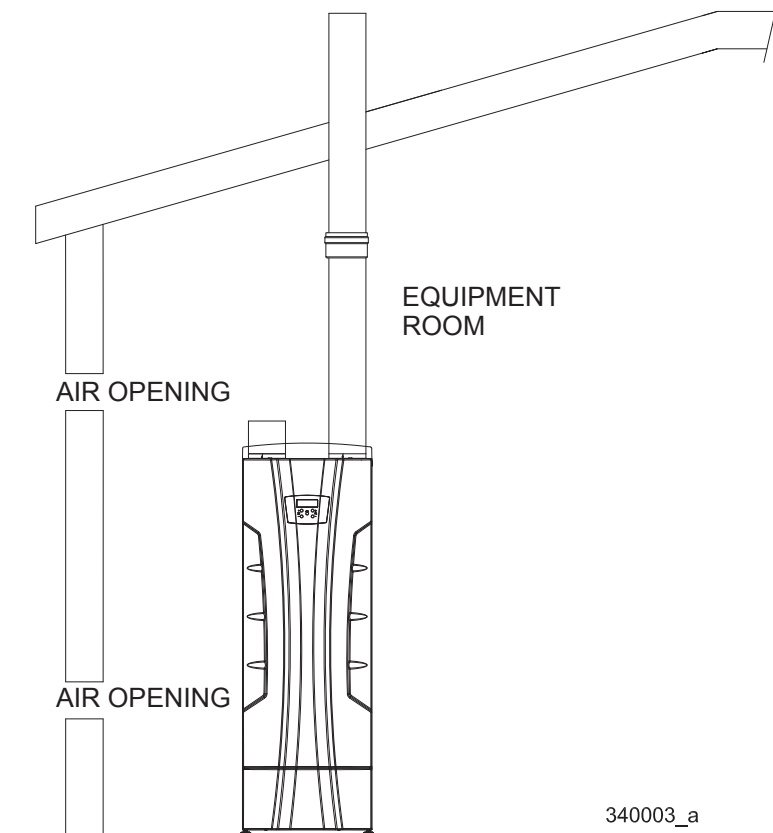

Figure 5-1 Combustion Air direct from outside

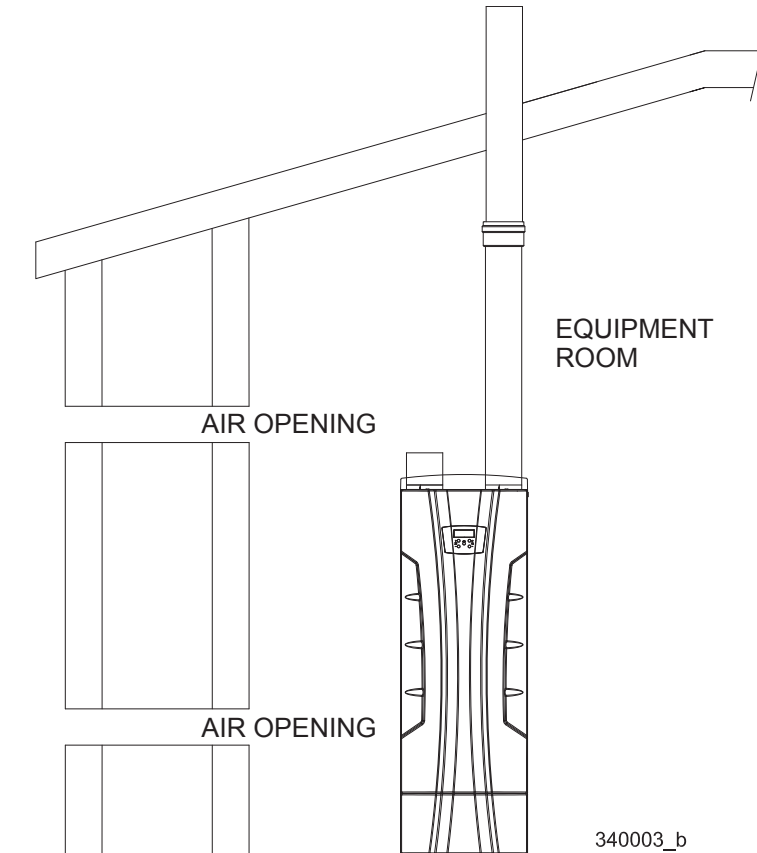

Figure 5-2 Combustion Air through Ducts

5 - INSTALLATION - Location

3. If a single combustion air opening is provided to bring combustion air in directly from the outdoors, the opening must be sized based on a minimum free area of one square inch per 3000 Btu/hr (7 cm² per kW). This opening must be located within 12" (30cm) of the top of the enclosure (see Fig.5-3).

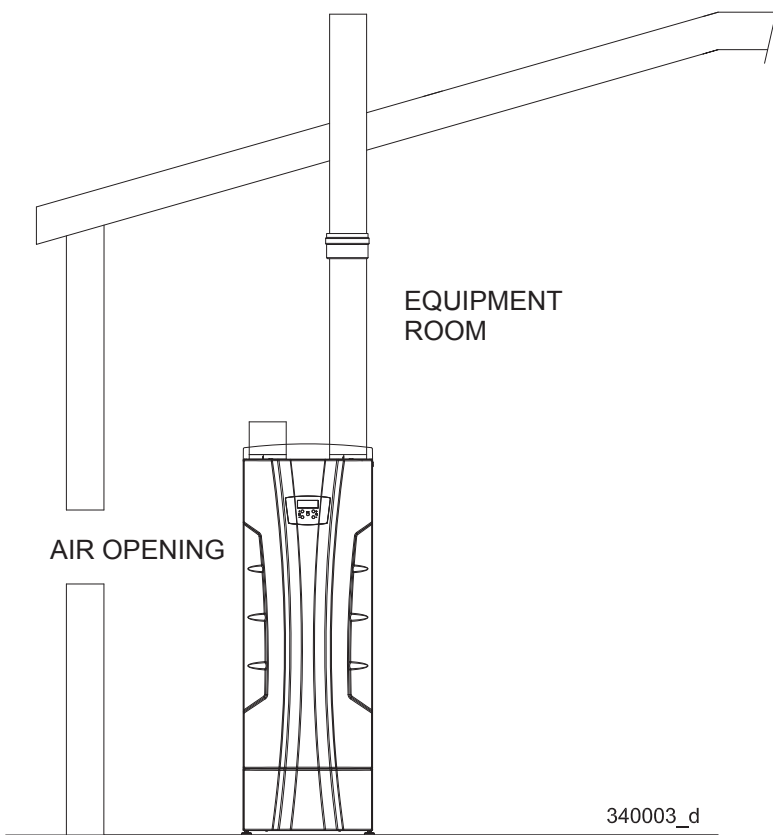

Figure 5-3 Combustion Air from outside - single opening

5 - INSTALLATION - Location

MINIMUM RECOMMENDED COMBUSTION AIR SUPPLY TO EQUIPMENT ROOM					
Model Number	* Outside Air from 2 openings Directly from Outdoor		* Outside Air from 1 Opening Directly from Outdoors, in ²	Inside Air from 2 Ducts Delivered from Outdoors	
	Top Opening, in ²	Bottom Opening, in ²		Top Opening, in ²	Bottom Opening, in ²
199	50 (323 cm ²)	50 (323 cm ²)	67 (433 cm ²)	100 (646 cm ²)	100 (646 cm ²)
399	100 (646 cm ²)	100 (646 cm ²)	134 (865 cm ²)	200 (1201 cm ²)	200 (1201 cm ²)
500	125 (807 cm ²)	125 (807 cm ²)	167 (1078 cm ²)	250 (1613 cm ²)	250 (1613 cm ²)
750	188 (1213 cm ²)	188 (1213 cm ²)	250 (1613 cm ²)	375 (2420 cm ²)	375 (2420 cm ²)
1000	250 (1613 cm ²)	250 (1613 cm ²)	334 (2155 cm ²)	500 (3226 cm ²)	500 (3226 cm ²)

* Outside air openings shall directly communicate with the outdoors. When combustion air is drawn from the outside through a duct, the net free area of each of the two openings must have twice (2 times) the free area required for Outside Air/2 Openings. The above requirements are for the water heater only; additional gas fired appliances in the equipment room will require an increase in the net free area to supply adequate combustion air for all appliances.

Figure 5-4 Minimum recommended combustion air supply to equipment room

Combustion air requirements are based on the latest edition of the National Fuel Gas, ANSI Z223.1; in Canada refer to the latest edition of CGA Standard CAN B142.2. Check all local code requirements for combustion air.

All dimensions based on net free area in square inches. Metal louvers or screens reduce the free area of a combustion air opening a minimum of approximately 25%. Check with louver manufacturers for exact net free area of louvers. Where two openings are provided, one must be within 12" (30 cm) of the ceiling and one must be within 12" (30 cm) of the floor of the equipment room. Each opening must have net free area as specified in the chart on Figure 5-4. Single openings shall commence within 12" (30 cm) of the ceiling.

5 - INSTALLATION - Location

WARNING!!!

Under no circumstances should the equipment room ever be under negative pressure. Particular care should be taken where exhaust fans, attic fans, clothes dryers, compressors, air handling units, etc., may take away air from the unit.

WARNING!!!

EXHAUST FANS: Any fan or equipment which exhaust air from the equipment room may deplete the combustion air supply and/or cause a downdraft in the venting system. Spillage of flue products from the venting system into an occupied living space can cause a very hazardous condition that must be immediately corrected. Failure to follow this warning could result in excessive levels of carbon monoxide, which can cause severe personal injury or death.

WARNING!!!

The combustion air supply must be completely free of any flammable vapors that may ignite or chemical fumes which must be avoided are fluorocarbons and other halogenated compounds, most commonly present as refrigerants or solvents, such as Freon, trichlorethylene, perchlorethylene, chlorine, etc. These chemicals, when burned, form acids which quickly attack the heat exchanger tubes, headers, flue collectors, and the vent system.

The result is improper combustion and a non-warrantable, premature appliance failure.

5.1.1 Prevent combustion air contamination

Do not terminate vent/air in locations that can allow contamination of combustion air.

WARNING!!!

Contaminated combustion air will damage the heater, resulting in possible severe personal injury, death or substantial property damage.

Ensure that the combustion air will not contain any of the following contaminants.

Products that may contaminate the air combustion:

- Permanent wave solutions;
- Chlorinated waxes/cleaners;
- Chlorine-based swimming pool chemicals;
- Calcium chloride used for thawing;
- Sodium chloride used for water softening;
- Refrigerant leaks;
- Paint or varnish removers;
- Hydrochloric acid/muriatic acid;
- Cements and glues;
- Antistatic fabric softeners used in clothes dryers;
- Chlorine-type bleaches, detergents, and cleaning solvents found in household laundry rooms;
- Adhesives used to fasten building products and other similar products;

Do not pipe combustion air near sources of products that may contaminate the air combustion, like:

- Dry cleaning/laundry areas and establishments;
- Swimming pools;
- Metal fabrication plants;
- Beauty shops;
- Refrigeration repair shops;
- Photo processing plants;
- Auto body shops;
- Plastic manufacturing plants;
- Furniture refinishing areas and establishments;
- Remodeling areas;
- Garages with workshops.

5.1.2 Location of an IB boiler

When locating the boiler the following factors must be considered:

- ☞ location of the openings for the ventilation of the boiler room regardless whether the combustion air is taken from the outside (Direct Vent, sealed combustion) or inside (room air for combustion);
- ☞ the location of vent/air intake terminals;
- ☞ connection to the gas supply;
- ☞ connection to the water supply;
- ☞ connection to the heating system;
- ☞ connection to the electrical supply;
- ☞ disposal of the condensation produced by the boiler;
- ☞ connection to the room thermostat or equivalent device;
- ☞ piping of the safety relief valve discharge;
- ☞ connection of the outdoor temperature sensor;
- ☞ possible connection of an indirect water heater;
- ☞ If flooding is possible, elevate the boiler sufficiently to prevent water from reaching the boiler.

5.1.3 Location of an IW water heater

When locating the water heater the following factors must be considered:

- ☞ location of the openings for the ventilation of the boiler room regardless whether the combustion air is taken from the outside (Direct Vent, sealed combustion) or inside (room air for combustion).;
- ☞ the location of vent/air intake terminals;
- ☞ connection to the gas supply;
- ☞ connection to the water supply;
- ☞ connection to a storage water heater;
- ☞ connection to the electrical supply;
- ☞ disposal of the condensation produced by the heater;
- ☞ piping of the safety P-T relief valve discharge;
- ☞ If flooding is possible, elevate the appliance sufficiently to prevent water from reaching the unit.

5 - INSTALLATION - Location

5.2 - Residential garage installation

Take the following precautions when installing the heater in a residential garage. If the heater is located in a residential garage, it should be installed in compliance with the latest edition of the National Fuel Gas Code, ANSI Z223.1 and/or CAN/CGA-B149 Installation Code.

- ☞ Appliances located in residential garages and in adjacent spaces that open to the garage and are not part of the living space of a dwelling shall be installed not less than 18 inches (46 cm) above the floor.
- ☞ The appliance shall be located or protected so that it is not subject to physical damage by a moving vehicle.

5.3 - Closet and alcove installations

This heater is approved for the installation in an alcove or in a closet, for which you have to respect all next rules about clearances, ventings, ventilation openings as per this manual and the National Fuel Gas Code, ANSI Z223.1 /NFPA 54 and/or CAN/CSA B149.1, Natural Gas and Propane Installation Code.

⚠ WARNING!!! Do not use PVC/CPVC/Polypropylene exhaust pipe material into a closet or alcove. Into closet or alcove, the only exhaust pipe material accepted is stainless steel. Failure to follow this warning could result in excessive levels of carbon monoxide or a fire, which can cause severe personal injury or death!

5.4 - Clearances for installation and servicing

Figures 5-6 and 5-7 shows the minimum clearances required for installation and servicing.

NOTICE! Service clearances are not mandatory, but are recommended to ensure ease of service should it be required.

5.5 - Clearances from combustible material

This heater may be installed directly onto a floor of combustible material. See also Figure 5-5 for other clearances from combustible materials.

5.6 - Vent and combustion air piping

This heater requires a special vent system, designed for pressurized venting.

The heater is to be used for either direct vent installation or for installation using room combustion air. When room air is considered, see Sections 5.1 and 12.9.

Vent and air may be vented vertically through the roof or out a side wall, unless otherwise specified. You may use any of the vent/air piping methods covered in Sections 12 and 13.

⚠ WARNING!!! Do not attempt to install the heater using any other venting / air intake methods than as explained on Sections 12 and 13. Failure to follow this warning could result in excessive levels of carbon monoxide or a fire, which can result in severe personal injury or death!

Be sure to locate the heater such that the vent and air piping can be routed through the building and properly terminated.

The vent/air piping lengths, routing and termination method must all comply with the methods and limits given in Sections 12 and 13.

5.7 - Prevent combustion air contamination

Install air inlet piping for the heater as described in Sections 12 and 13. Do not terminate vent/air in locations that can allow contamination of combustion air. Refer to Section 5.1.1, for products and areas which may cause contaminated combustion air.

⚠ WARNING!!! Ensure that the combustion air will not contain any of the contaminants listed in Section 5.1.1. Contaminated combustion air will damage the heater, resulting in possible severe personal injury, death or substantial property damage.

CLEARANCES FROM COMBUSTIBLE MATERIALS	
Ceiling	2 inches (51 mm)
Front	2 inches (51 mm)
Rear	2 inches (51 mm)
Sides	2 inches (51 mm)
Floor	0 inches (0 mm)
Concentric vent	0 inches (0 mm)
Split vent (two pipes), first 3 ft from the appliance	1 inch (25 mm)
Split vent (two pipes), after 3 ft from the appliance	1/4 inch (7 mm)
Supply and return piping	1/4 inch (7 mm)

Figure 5-5; Clearances from combustible material

5 - INSTALLATION - Location

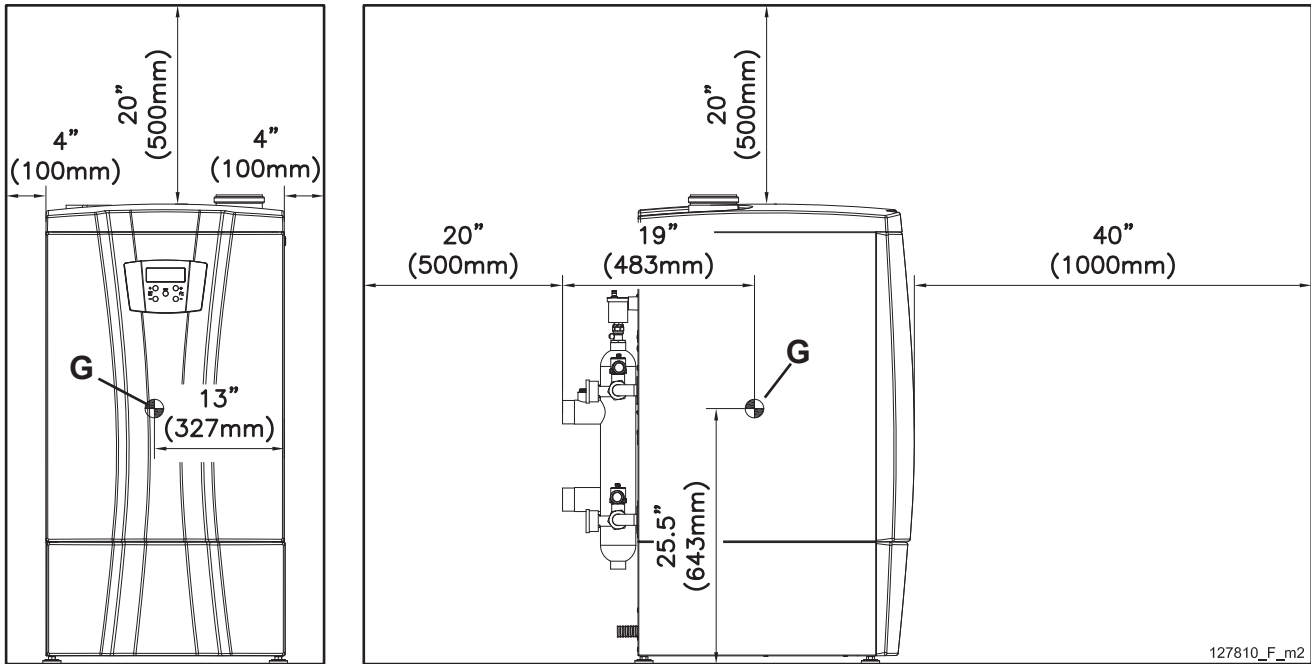

Figure 5-6 Recommended minimum clearance distances for proper installation and servicing for models 199, 399 and 500 (G = Center of gravity)

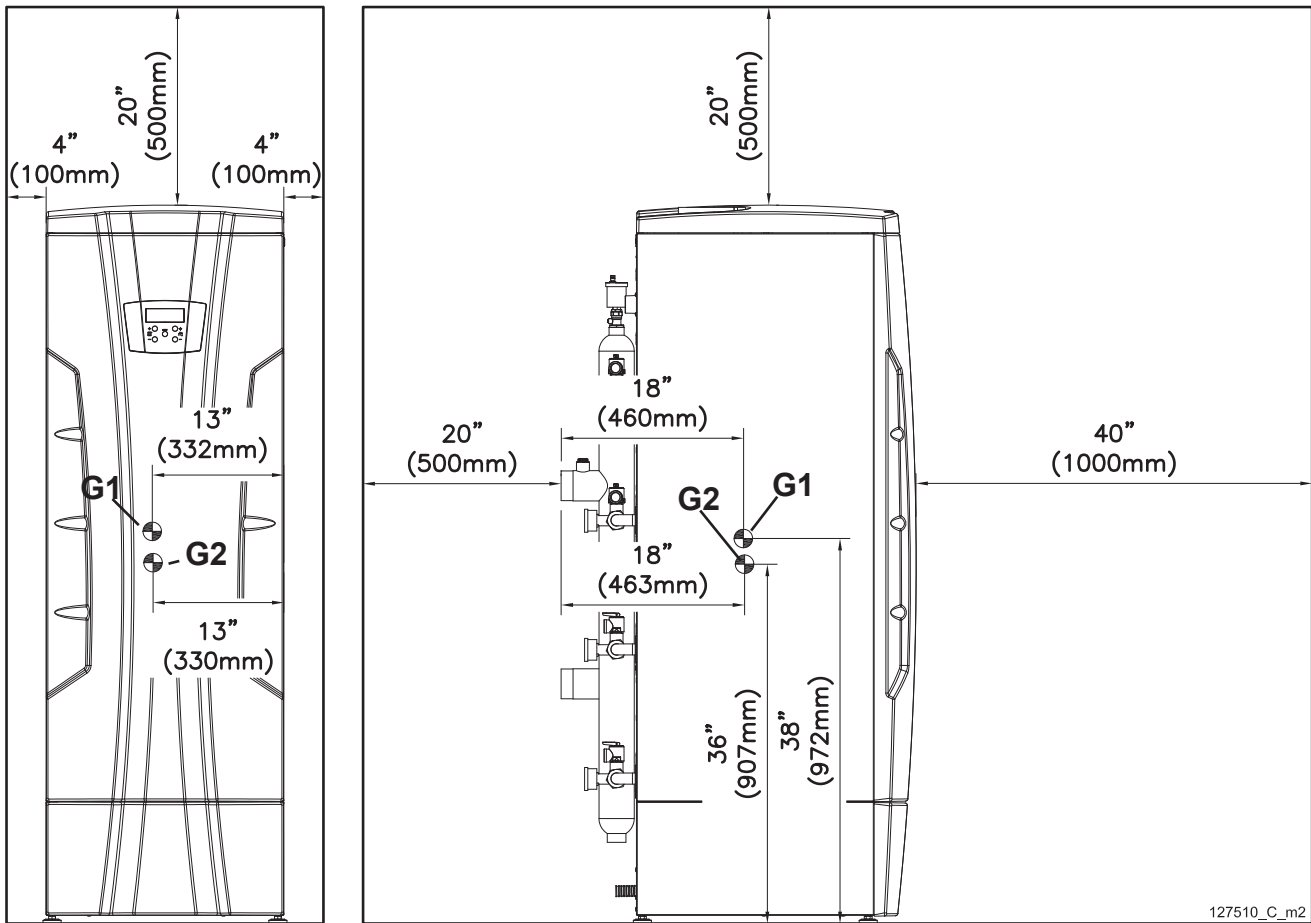

Figure 5-7 Recommended minimum clearance distances for proper installation and servicing for models 750 and 1000 (G1 = Center of gravity for 1000 model G2 = Center of gravity for the 750 model)

6 - INSTALLATION - Mounting the heater

6.1 - Transporting the heater

⚠ WARNING!!! Always lift and carry the heater with a hand truck or special equipment. Failure to comply with this provision could result in severe personal injury, death or substantial property damage.

⚠ CAUTION!!! The heater may be damaged when it is improperly secured and transported.

⚠ CAUTION!!! The unpacked heater may be damaged when not protected against contamination.

- ☞ Only transport the heater using the right transportation equipment, such as a hand truck with a fastening belt or special equipment for maneuvering steps.
- ☞ During transportation the heater must be secured on the transportation equipment to prevent it from falling off.
- ☞ Protect all parts against impacts if they are to be transported.
- ☞ Leave the protective covers on the connections.
- ☞ During transportation, cover the flue gas and air intake connections at the top of the heater with plastic film.

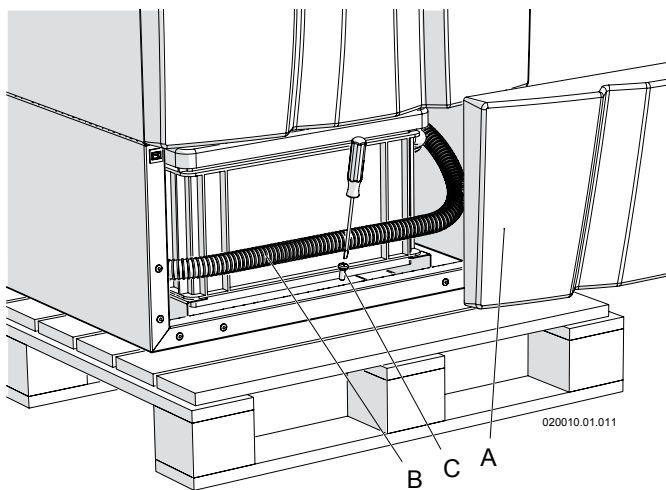

Figure 6-1 Remove heater from wood pallet

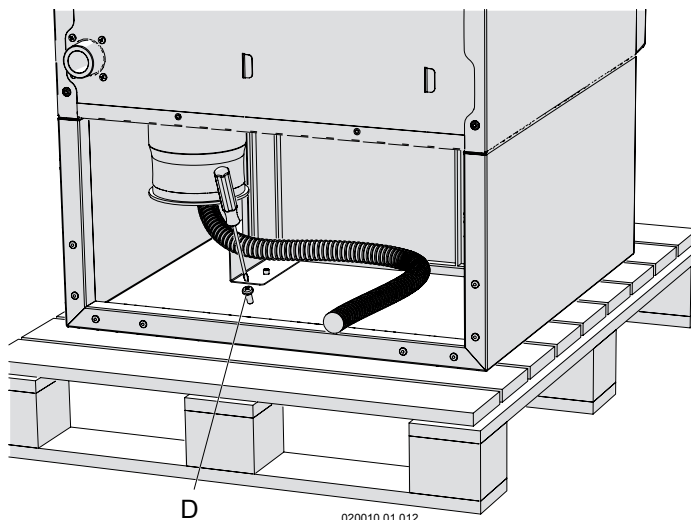

Figure 6-2 Remove heater from wood pallet

6.2 - Mounting the heater

1. Remove the outer shipping carton from the heater.
2. Remove the front door (see Section 17.2) to access the screw "C" (Figure 6-1) in front of the unit.
3. Remove the screw "D" in the rear of the unit (Figure 6-2).

6 - INSTALLATION - Mounting the heater

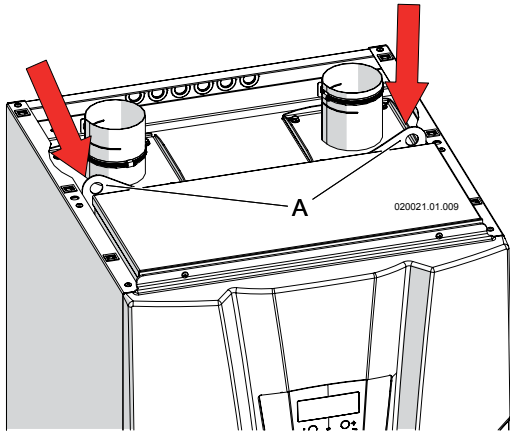

Figure 6-3 Bracket to lift the appliance

4. Access to the uplift brackett "A" (Figure 6-3) on the upper side of the heater (see Figure 6-3);
5. Using a proper equipment (check the weight of the unit in Section 18), and lift the unit from the wood pallet and move it to the installation location;
6. Install the leveling feet and plumb the unit accordingly (see Figure 6-5).

⚠ WARNING!!! The floor must be capable of supporting the weight (see Section 18) of the unit or the same unit and building may be damaged causing severe personal injury, death, or substantial property damage.

6.3 - Dimensions

Figures from 6-6 and 6-7 list all dimensions of each heater model.

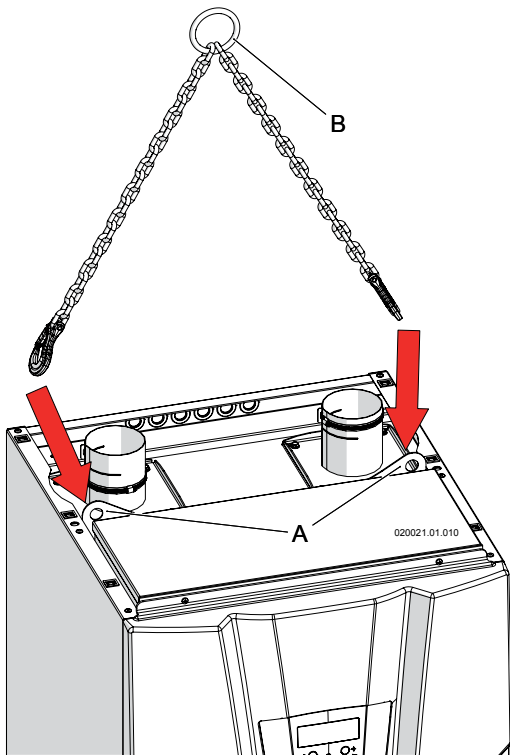

Figure 6-4 Correct way to lift the appliance

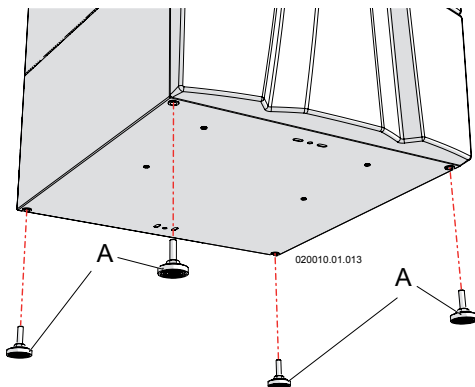
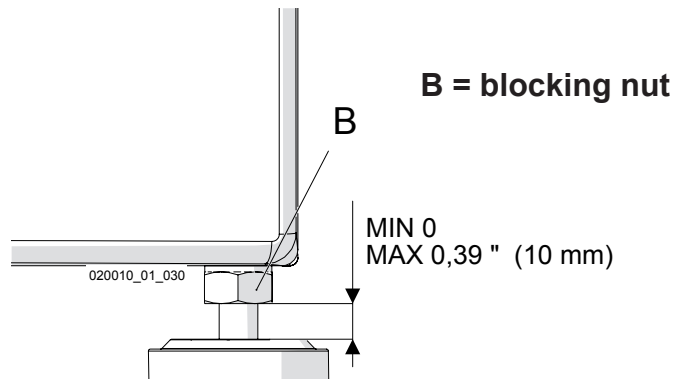

Figure 6-5 Install leveling feet



6 - INSTALLATION - Mounting the heater

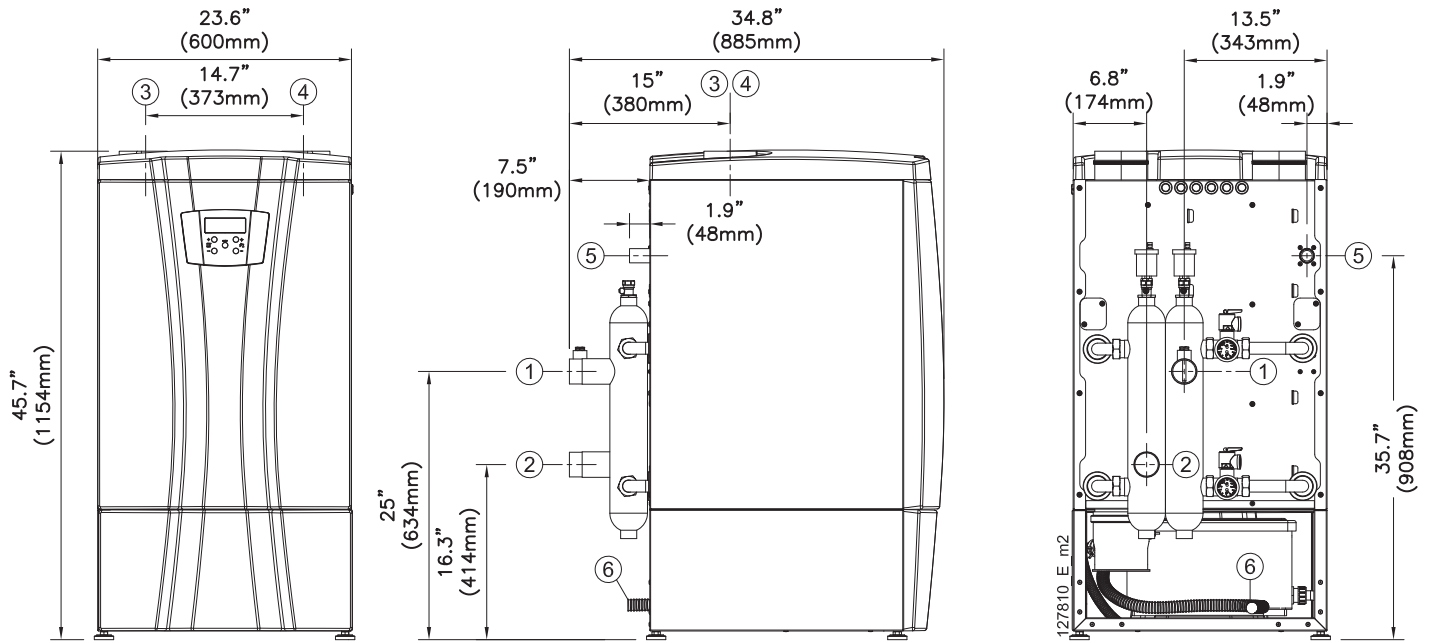

Figure 6-6 Dimensions for models 199, 399 and 500.

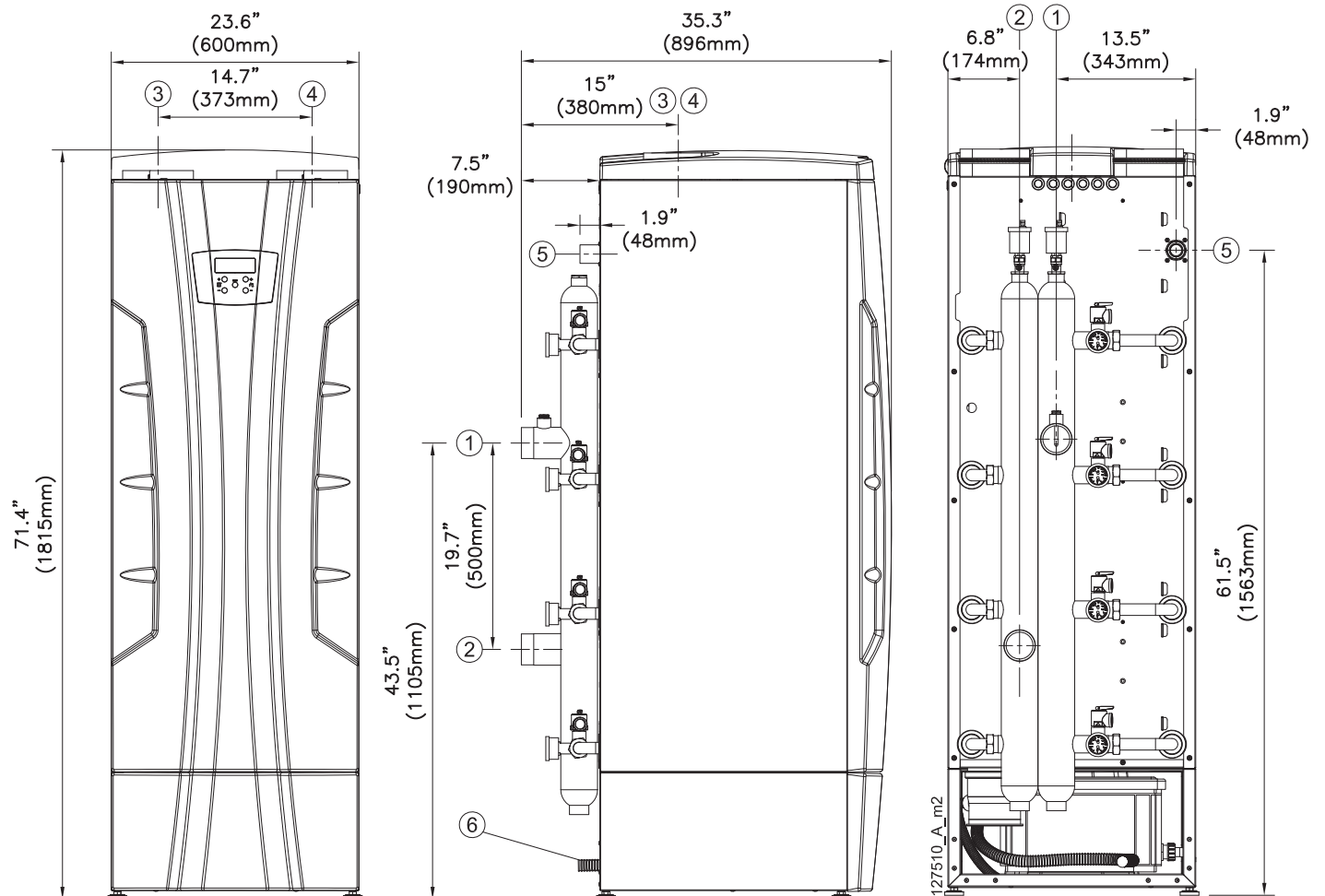

Figure 6-7 Dimensions for models 750 and 1000

6 - INSTALLATION - Mounting the heater

MODEL	① WATER SUPPLY CONNECTION	② WATER RETURN CONNECTION	③ AIR INTAKE CONNECTION	④ FLUE EXHAUST CONNECTION	⑤ GAS CONNECTION	⑥ CONDENSATE HOSE
199	2"	2"	3"	3"	1"	1" 1/4
399	2"	2"	4"	4"	1"	1" 1/4
500	2"	2"	4"	4"	1"	1" 1/4
750	2" 1/2	2" 1/2	6"	6"	1" 1/4	1" 1/4
1000	2" 1/2	2" 1/2	6"	6"	1" 1/4	1" 1/4

Figure 6-8 - Table of diameters connections of figures 6-6 and 6-7

7 - INSTALLATION - IB boiler water connection

7.1 - IB boiler water connections

The boiler comes with the connections shown in Figures 6-6 and 6-7.

7.1.1 Boiler water chemistry

CAUTION!!! Risk of system damage due to unsuitable heating system water. If the heating water is not with the features required in this section, the system water must be separated from the boiler water by a plate heat exchanger able to resist the corrosion. Unsuitable heating system water promotes lime scale fouling, corrosion and deposits formation. This can result in boiler damage and malfunction.

Scale and Corrosion

Free oxygen can cause the formation of rust (iron oxides), which degrade metallic materials.

Magnetite is formed in un-inhibited water if there is electrolytic action in the presence of oxygen.

Sludge is formed when calcium compounds, primarily CaCO₃, are heated. Rust and magnetite, when combined with sludge, can form a very hard scale, which significantly reduces system efficiency and life expectancy of the heating system. Scale reduces heat exchange due to its low heat conductivity and so may cause very dangerous localized overheating. Waterside corrosion of all heating circuit surfaces is also a major concern.

Make-up or Feed Water Quality

Make-up or feed water is water added to a closed hydronic system to replenish water lost through evaporation, maintenance, or leakage. The quality of make-up or feed water, which may contain dissolved oxygen, minerals and other dissolved contaminants, is extremely important. Such introduced water must be chemically treated or strictly limited when ensuring neutral chemical conditions in boiler system water. Generally, any closed hydronic heating

system should be restricted from receiving untreated makeup water of no more than 5% of the total volume of system water per year.

Treating Water to Prevent Freezing

When using anti-freeze solutions, their compatibility with the heat exchanger and other components of the heating system must be determined prior to use. If a glycol solution is used as anti-freeze protection, a backflow preventer must be installed upstream of the fill/makeup valve.

Only virgin glycol should be used for systems requiring freeze protection, and it must be treated with an inhibitor compatible with the particular chemical treatment being used in the system. Note that glycol must be changed from time to time due to its limited useful life.

Use only inhibited propylene glycol solutions, formulated for hydronic systems. Ethylene glycol is toxic and can attack gaskets and seals used in hydronic systems.

! WARNING!!! Never use non-approved additives or toxic boiler treatment chemicals in the heating system as they can cause serious health problems or possibly death. Any additives introduced into the heating system must be recognized as safe by the United States Food and Drug Administration.

! WARNING!!! Use only inhibited propylene glycol solutions, which are specifically formulated for hydronic systems. Ethylene glycol is toxic and can attack gaskets and seals used in hydronic systems. Failure to comply with this provisions could result in severe personal injury, death or substantial property damage.

Water Treatment Certification

When using chemical treatments in hydronic systems, it is necessary to ensure that the chosen treatment is appropriate and certified by the manufacturer for such environments. The manufacturer should also guarantee that the treatment,

when applied according to the manufacturer's recommendations, will not cause harm to the boiler, pumps, piping, and other components of the hydronic boiler system.

7.1.2 Testing and maintenance of water quality

Water in the installation should be checked, monitored, and treated for the following conditions and characteristics:

☞ **Hardness** – High hardness of the available water is measured in grains of hardness and indicates the quantity of minerals (mostly calcium and magnesium) which are dissolved in the water. Hardness substantially contributes to the formation of scaling, which is highly undesirable. The total hardness must be less than 200 ppm total dissolved solids (TDS).

☞ **Chloride** – Chlorides are salts resulting from the combination of the gas chlorine with a metal and are instrumental in accelerating corrosion in the types of metals used in hydronic systems. Chlorides may be introduced into the water naturally. Concentrations of chlorides in system water should be less than 150 ppm.

☞ **Conductivity** – Dissolved metals and minerals increase the conductivity of water and indicate not only the presence of undesired corrosive agents, but also contribute to the transfer and migration of ions and charged particles in the water that contribute to fouling of sensors, valves, and other devices used in the system. Additionally, high conductivity contributes to galvanic corrosion, in which one metal will preferentially corrode when in contact with another type of metal, when both are in contact with an electrolyte. Conductivity should be less than 3000 µS.

☞ **pH** – The pH, a measure of the acidic, neutrality, and alkalinity of the water, must always be between 7.5 and 9.5.

☞ **Oxygen** – All precautions should be taken to avoid the formation and localization of oxygen in the

7 - INSTALLATION - IB boiler water connections

water of a heating system. Water that is low in minerals (soft water) absorbs oxygen much more readily than mineralized (hard) water. For this reason it is necessary that in heating systems using floor radiant heating, the plastic pipes used be impermeable to oxygen.

☞ **Scale and Corrosion** – The use of an inhibitor is advisable to treat feed and make-up water and to protect heating systems against scale, corrosion and microbiologic growth. To prevent freezing, the use of an anti-freezing agent together with the inhibitor is advisable. Qualified companies can also provide boiler de-scaling.

☞ **Water treatment** is also advisable in the following cases:

- Very large heating systems
- High quantities of replenished water due to leakages or maintenance work

7.1.3 System flushing, treatment, and cleansing

Note that prior to cleaning the heating system, the boiler MUST be isolated from the piping to prevent infusion of contaminants, including sludge, into the boiler.

CAUTION!!! Cleaning solution and inhibitors used must be compatible with heat exchanger material. Corrosion/scale inhibitor will be ineffective if added to a dirty system; therefore, it is very important to clean the system first.

CAUTION!!! The manufacturer cannot be held responsible for any damage caused by incorrect use of additives in the heating system.

When cleaning, treating, and maintaining, a heating system, consult a qualified professional. The following are tips/guidelines for cleaning a heating system – these do NOT take precedence over detailed instructions from qualified professionals.

☞ Make sure to use an appropriate amount of cleaning solution, carefully following the manufacturer's instructions. Follow the chemical manufacturer's recommendations when introducing cleaning agents into the system.

☞ Ensure that the cleaning solution is circulated thoroughly in the system.

☞ Flush the system thoroughly to remove the maximum amount of contaminants. When emptying the system, make sure it is done as quickly as possible using all drain off points and ensuring all low lying pipework is fully drained. Opening all bleed valves ensures the system will be completely emptied.

☞ A reliable test to determine if a system is clean is if the Total Dissolved Solids (TDS) of the water being drained is within 10% of the make-up water TDS. This indicates that sufficient contamination has been flushed from the system. If the difference in TDS is more than 10%, it is recommended to repeat the cleaning process until that is achieved. A turbidity test can be used as an alternate way to determine if a system is clean.

☞ For boiler retrofit/replacement installation, it will be necessary to repeat the cleaning process until the draining water appears to be clear. Once clear, the above TDS comparison (or a turbidity test) should be performed.

☞ If a flushing machine is used in the cleaning process, carefully follow the manufacturer's instructions. If the flushing machine is designed to flush individual zones, the TDS comparison must be made between each zone and the make-up water, or the turbidity test performed for each zone.

☞ Add corrosion and scale inhibitor after the system has been declared clean, using the appropriate amount recommended by the manufacturer. Introduce the protector/scale inhibitor to the system following the chemical treatment manufacturer's instructions. Adding inhibitor to a dirty system reduces its

effectiveness. When refilling the system, ensure the boiler is not air-bound by opening the pressure-relief valve. Leave the relief valve open until a steady flow of water is observed. Close the valve and finish filling the system.

7.1.4 Water Quality Maintenance and Warranty

Heat exchanger failures due to improperly cleaned/treated and poorly maintained water are not covered under warranty. Scheduled system/boiler water maintenance is required to maintain the heat exchanger warranty. Boiler manufacturer shall reserve the right to require maintenance records when evaluating warranty claims.

7.1.5 Water Treatment Analysis and Scheduling

The proper mixture of water, chemical treatment, and glycol (if used) should be ascertained based on a sample of the system water and the make-up water. Your local water treatment company, may analyze your sample. Adjust the chemical composition of your system water based on the analysis. After this initial analysis, the chemical composition of your system water should be tested at the beginning of each heating season. For boilers operating year round, this analysis should be made at least twice a year.

7 - INSTALLATION - IB boiler water connection

7.2 - Supply and return piping

The boiler is equipped with ASME safety relief valves set at 50 PSI (3,4 bar). However, this boiler can be equipped with relief valves set at maximum 160 PSI (11.2 bar) that is the maximum working pressure.

CAUTION!!! All heating system piping must be installed in accordance with the ANSI/ASME Boiler and Pressure Vessel Code, Section IV. All applicable local codes and ordinances must also be followed.

CAUTION!!! The heating system must be designed so that no piping or radiation elements are higher than the correspondent maximum pressure of the relief valve or else the hydraulic head of the system will cause the relief valve to open.

CAUTION!!! This boiler can supply heating water at a temperature up to 203°F (95°C) (setup of the safety high limit thermostat) and pressure of 160PSI (11,2 bar). If the heating system is built with materials not able to resist to this temperature and pressure, contractor must supply and install a device that will shut-off the boiler before the system material's maximum operating temperature and pressure are met.

CAUTION!!! Do not use the boiler to directly heat domestic hot water, swimming pool or spa water.

CAUTION!!! This boiler is capable of servicing multiple temperature loop systems. It is the responsibility of the installer to protect the loops with lower temperature requirements from higher temperatures that may be required by other loops.

System water piping methods

This boiler is designed to function in a closed loop pressurized system no less than 15 psi (1 bar). A pressure gauge is included to monitor system pressure. Each boiler installation must have an air elimination device, which will remove air from the system. Install the boiler so the gas ignition system components are protected from water (dripping, spraying, etc.), during appliance operation for basic service of circulator replacement, valves, and others.

Low water cutoff device

On a boiler installed above radiation level, some states and local codes require a low water cutoff device at the time of installation. The low water cutoff terminals are present within the line voltage junction box. See also section 10.1.6

Freeze protection

Freeze protection for new or existing systems must use glycol that is specially formulated for this purpose. This includes inhibitors, which prevent the glycol from attacking the metallic system components. Make certain to check that the system fluid is correct for the glycol concentration and inhibitor level. The system should be tested at least once a year and as recommended by the producer of the glycol solution. Allowance should be made for the expansion of the glycol solution in the system piping.

! WARNING!!! Never use non-approved additives or toxic boiler treatment chemicals in the heating system as they can cause serious health problems or possibly death. Any additives introduced into the heating system must be recognized as safe by the United States Food and Drug Administration.

! WARNING!!! Use only inhibited propylene glycol solutions, which are specifically formulated for hydronic

systems. Ethylene glycol is toxic and can attack gaskets and seals used in hydronic systems. Failure to comply with these provisions could result in severe personal injury, death or substantial property damage.

CAUTION!!! If glycol is used, it must be used in accordance with the instructions supplied with the product.

CAUTION!!! Any additives added to the heating system must not be added directly inside the boiler but through the heating system piping to prevent damage to the boiler.

Floor radiant heating systems

Setting parameter 3015 (see Section 21), the boiler will maintain the maximum supply water temperature at that range temperature. No setting changes made from the control panel will cause the supply water temperature to exceed the maximum stated.

CAUTION!!! To protect the radiant floor panel against over heating you must install a safety device that shuts-off the boiler before it reaches the floor panel's limit temperature.

CAUTION!!! Risk of system damage due to unsuitable heating system water. If oxygen-permeable pipes are used, e.g. for under floor heating systems, the systems must be separated from one another by plate heat exchangers able to resist the corrosion. Unsuitable heating system water promotes sludge and corrosion formation. This can result in boiler damage and malfunction.

7 - INSTALLATION - IB boiler water connections

7.2.1 - Near boiler heating piping components

1. Boiler system piping: boiler system piping **MUST** be properly sized. Reducing the pipe size can restrict the flow rate through the boiler, causing inadvertent high limit shutdowns and poor system performance.
2. Boiler system pump: Field supplied. The system pump **MUST** be sized to meet the specified flow requirements.
3. Indirect water heater circulating pump: Field supplied. The pump **MUST** be sized to meet the specified flow requirements. Consult the indirect water heater operating guide to determine flow characteristics for the selected product used.
4. Boiler isolation valves: Field supplied. Full port ball valves are required. Failure to use full port ball valves could result in a restricted flow rate through the boiler.
5. Check valve: Field supplied. Check valves are recommended for installation as shown in Figure 7-3. Failure to install these valves could result in a reverse flow condition during pump(s) off cycle.
6. Domestic indirect hot water isolation valves: Field supplied. Full port ball valves are required. Failure to use full port ball valves could result in a restricted flow rate through the boiler.
7. If the boiler is connected to an indirect water heater for domestic hot water, an Anti-scald mixing valve (Field supplied) **MUST** be installed.
8. Unions: Field supplied. Recommended for unit serviceability.
9. Pressure relief valve: Factory installed. The pressure relief valve is sized to ASME specifications (see also Section 7.2.2).

10. Indirect water heaters: field supplied. This boiler may be piped to an indirect water heater to heat domestic hot water with the space heat transfer medium. The indirect water heater is connected to the system supply piping. A pump controlled by the boiler's control will regulate the flow of water through the indirect water heater. The indirect water heater's temperature will be regulated by the boiler's control. The boiler is pre-configured to control the operation of the DHW pump with Domestic Hot Water Prioritization programming.

CAUTION!!! It is up to the installer to ensure the minimum system flow is not less than the stated on section 18, at any time. If the flow is lower, the boiler automatically stops the burner.

WARNING!!! The National Standard Plumbing Code, the National Plumbing Code of Canada and the Uniform Plumbing Code limit the pressure of the heat transfer fluid to less than the minimum working pressure of the potable water system up to 30 psi maximum. Also, the heat transfer fluid must be water or other non-toxic fluid having a toxicity of Class 1, as listed in Clinical Toxicology of Commercial Products, 5th Edition. Failure to comply with this provisions could result in severe personal injury or death.

11. Filter: Field supplied. A filter or equivalent multipurpose strainer is recommended at the return pipe of the boiler to remove system particles from older hydronic systems and protect newer systems. **NOTICE!** Filter will be able to stops particles with an equivalent volume of a spheres with diameter of 0.04" (1mm);

12. Header temperature sensor relocation: The header temperature sensor is factory installed (see item "39", Figures 3-5, 3-8 and 3-11). However, in some piping installations with primary/secondary looping (see Figure 7-3), the header temperature sensor must be relocated in the system loop to better measure the temperature changement. In order to relocate the header sensor, operate as follow:

- a. - install a well useful for the header temperature sensor, in the position shown in Figure 7-3. Be carefully to respect the position illustrated. The header sensor must detect the temperature of the primary flow and of the secondary flow.
- b.- remove the header temperature sensor from its original position and relocate the sensor into the well precedently installed. If the length of the sensor is not enough, you can extend it using a #18 AWG cable.

WARNING!!! Since the header temperature sensor wires conduct 24 Vac, they must never run through conduits containing 120Vac power wires or an electrical shock hazard will exist.

7 - INSTALLATION - IB boiler water connections

7.2.2 - Relief valve

This boiler is supplied with a Safety Relief valve installed in accordance with the ANSI/ASME Boiler and Pressure Vessel Code, Section IV. Pipe the relief valve discharge like on Figure 7-1 to prevent scalding in the event of a discharge. Pipe the discharge of the safety relief valve to a suitable drain. Provide piping that is the same size as the safety relief valve outlet.

⚠ WARNING!!! Failure to properly pipe the relief valve discharge can result in scalding of individuals and animals.

⚠ WARNING!!! Never install any type of valve between the boiler and the relief valve or an explosion causing extensive property damage, severe personal injury or death may occur!

⚠ WARNING!!! Never block or plug the outlet of the safety relief valve or an explosion causing extensive property damage, severe personal injury or death may occur!

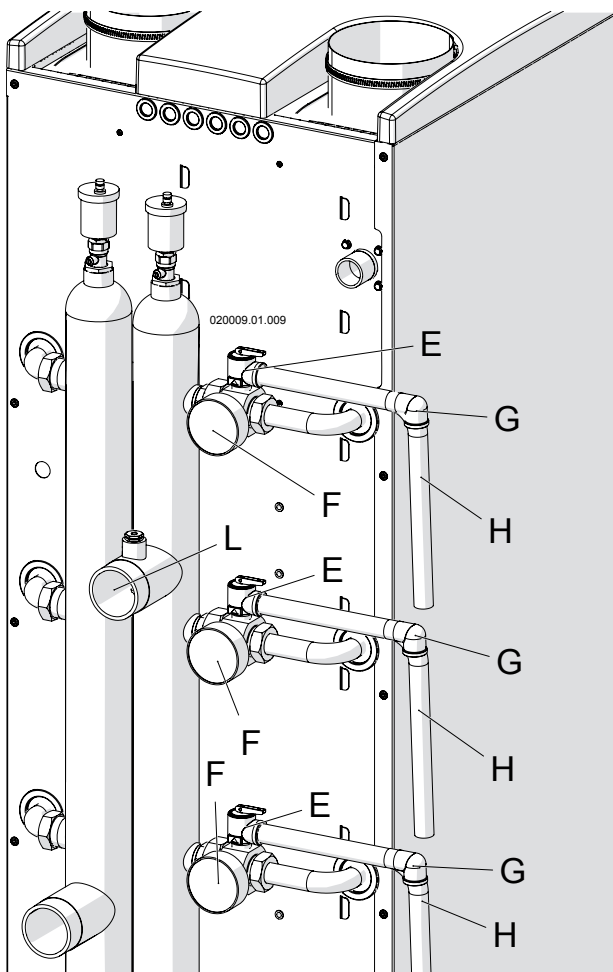

Figure 7-1 Piping the relief valve discharge

7.2.3 - Expansion Tank and Makeup Water

Install an expansion tank. Ensure the expansion tank is properly sized for the boiler volume (See Section 18, header "Content of water") and the system volume, temperature and pressure.

⚠ CAUTION!!! Undersized expansion tanks will cause system water to be lost through the pressure relief valve and cause additional makeup water to be added to the system. Eventual boiler failure can result due to this excessive makeup water addition, compromising the functionality of the unit.

The expansion tank must be located as shown in Figure 7-3 when using a primary/secondary piping arrangement or as per recognized design methods. Refer to the expansion tank manufacturer instructions for additional installation details. Connect the expansion tank to an air separator only if the air separator is located on the suction side (inlet) of the system circulator.

Always locate and install the system fill connection at the same location as the expansion tank connection to the system.

Key to Figure 7-1

E = Safety relief valve

F = Temperature and pressure gauge

G = Elbow (Field provided)

H = Relief valve discharge piping (Field provided)

L = Heating supply connection

7 - INSTALLATION - IB boiler water connections

7.2.4 - Local boiler pump and CH pump

This boiler must be fitted with a local pump. To connect the local pump to the boiler see Figure 7-3 and electrically connect the pump on terminals as shown on Figure 10-4. A field supplied pump relay must be installed if the pump current draw is greater than 3 amps.

The water resistance to size the local pump to supply flow through the heating system at the boiler connections is shown in graph form in Figure 7-2.

CAUTION!!! It is up to the installer to ensure the minimum system flow is not less than the stated on section 18, at any time. If the flow is lower, the boiler automatically stops the burner.

To connect an heating pump (CH pump) on the secondary loop see Figure 7-3 and electrically connect the pump on terminals as shown on Figure 10-4. A field supplied pump relay must be installed if the pump current draw is greater than 3 amps.

7.2.5 - Sizing heating system

Size the pump, piping and system components required in the space heating system, using recognized design methods.

7.2.6 - Domestic Hot Water system Piping when using an indirect water heater

See Figure 7-3, for recommended piping to an indirect water heater. This recommended piping configuration ensures priority is given to the production and recovery of DHW.

Refer to Figure 10-4 to wire the indirect water heater pump (DHW pump)

Anti-scald mixing valve: Field supplied. An anti-scald mixing valve is mandatory on the domestic hot water outlet of the indirect water heater

WARNING!!! Install an anti scald mixing valve downstream domestic hot water piping. Failure to comply with this provision can result in scalding of individuals and animals causing, severe personal injury or death!

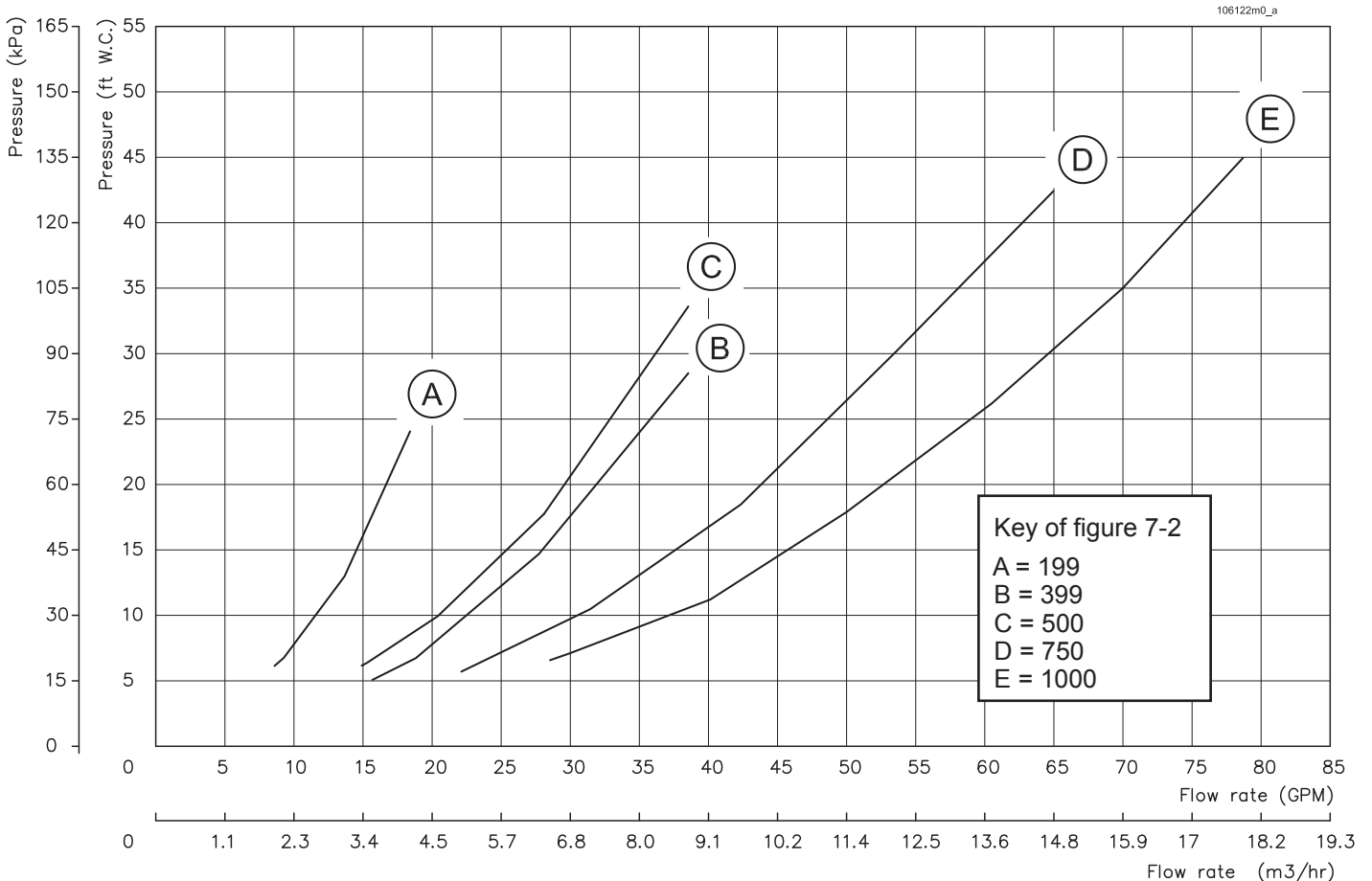
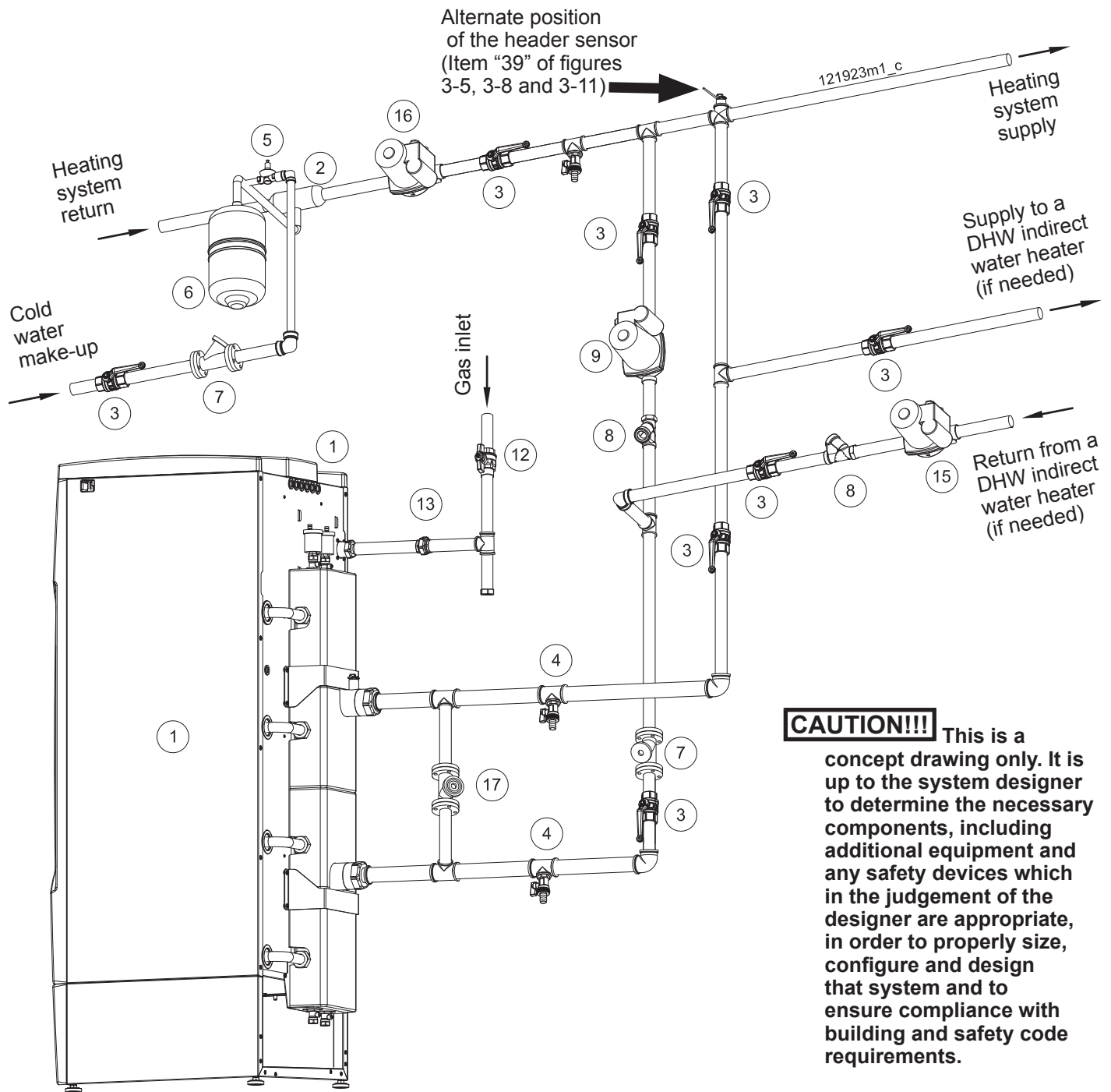

Figure 7-2 Water side head loss of the heater

7 - INSTALLATION - IB boiler water connections



- 1 = IB Boiler
- 2 = Air separator
- 3 = Ball valve
- 4 = Drain valve
- 5 = Filling valve
- 6 = Expansion tank
- 7 = Filter
- 8 = Check valve

- 9 = Local boiler pump
- 12 = Manual Gas shut-off valve (Install manual shut-off valve 5 ft (1.5m) above floor)
- 13 = Ground joint union
- 15 = Indirect water heater pump (DHW pump) (if needed)
- 16 = Heating pump (CH pump)
- 17 = Balancing valve (mandatory if heater is equipped with motorized valve, item "17" Fig. 3-1)

Figure 7-3 Piping of IB boilers

8 - INSTALLATION - IW water connections

8.1 - IW Water heaters' water connections

The water heater comes with the connections shown in Figures 6-6 or 6-7.

8.2 - Hot and Cold water piping

The water heater is equipped with ASME safety P-T relief valves set at 125 PSI (8,6 bar) 210°F (99°C). However, this water heater can be equipped with P-T relief valves set at maximum 160 PSI (11.2 bar) 210°F (99°C) that is the maximum working pressure - temperature.

CAUTION!!! All water system piping must be installed in accordance with the ANSI/ASME Boiler and Pressure Vessel Code, Section IV. All applicable local codes and ordinances must also be followed.

CAUTION!!! Before connecting the water heater to the system this last must be thoroughly flushed to remove sediment, flux, filings and other foreign matter. The heat exchanger can be damaged by build-up or corrosion due to sediment.

CAUTION!!! This water heater can supply water at a temperature up to 203°F (95°C) (setup of the safety high limit thermostat) and pressure of 160 PSI (11,2 bar) (maximum setup of the relief valve). If the hot water system is built with materials not able to resist to this temperature and pressure, contractor must supply and install a device that will shut-off the appliance before the system material's maximum operating temperature and pressure are met.

CAUTION!!! Do not use this heater to directly heat swimming pool or spa water.

8.2.1 - Near water heater piping components

Water heater system piping MUST be sized considering the pressure drops of the water heater (see Figure 7-2), pipings and storage tank.

Reducing the pipe size can restrict the flow rate through the water heater, causing poor system performance. Basic steps are listed below along with illustrations on Figure 8-4, which will guide you through the installation of the water heater.

1. Connect the cold water supply to the inlet side of the water heater.
2. Connect the hot water supply to the outlet side of the water heater.
3. Install a backflow preventer (field supplied) on the cold feed make-up water line.
4. Install a field supplied pump as shown in Figure 8-4.
5. Install a field supplied expansion tank on the cold water inlet. Consult the tank manufacturer's instruction for specific information relating to tank installation. Size the expansion tank for the required system volume and capacity.

6. Install a drain valve at the lowest point of the system.
7. Pipe the discharge outlet of any Pressure and temperature relief valve following Section 8.2.2. The temperature and pressure relief valve is sized to ASME specifications. Storage tanks may require additional valves depending on local codes.
8. Water heater isolation valves: Field supplied. Install isolation valves as shown on figure 8-4. Full port ball valves are required. Failure to use full port ball valves could result in a restricted flow rate through the water heater.
9. Anti-scald mixing valve: Field supplied. Install an anti-scald mixing valve as shown on figure 8-4. An Anti scald mixing valve is recommended when storing domestic hot water above 115°F.
10. Unions: Field supplied. Install Unions as shown on Figure 8-4, recommended for unit serviceability.
11. Tank sensor: Factory supplied on water heater. The tank sensor MUST be installed in the lower 25% of the storage tank to achieve proper operation.
12. Filter: Field supplied. Install a filter or equivalent multipurpose strainer at the cold water inlet connection of the water heater to remove system particles from older hydronic systems and protect newer systems. **NOTICE!** Filter will be able to stops particles with an equivalent volume of a spheres with diameter of 0.04" (1mm).

Install the heater so the gas ignition system components are protected from water (dripping, spraying, etc.), during appliance operation for basic service or circulator, valves and other parts replacement.

8 - INSTALLATION - IW water connections

8.2.2 - Temperature and pressure Relief valve

This water heater is supplied with a Safety Temperature and Pressure Relief valve which discharge connection must be piped in accordance with the ANSI/ASME Boiler and Pressure Vessel Code, Section IV, to prevent scalding in the event of a discharge.

Pipe the discharge of the safety relief valve like on Figure 8-1. To a suitable drain to prevent injury in the event of pressure relief. Pipe the discharge to a drain. Provide piping that is the same size as the safety relief valve outlet.

! WARNING!!! Failure to properly pipe the relief valve discharge can result in scalding of individuals and animals.

! WARNING!!! Never block the outlet of the safety relief valve or an explosion causing extensive property damage, severe personal injury or death may occur!

! WARNING!!! Never install any type of valve between the water heater and the relief valve or an explosion causing extensive property damage, severe personal injury or death may occur!

NOTICE! The separate storage vessel must have a temperature and pressure relief valve installed. This relief valve shall comply with the Standard for Relief Valves for Hot Water Supply Systems, ANSI Z21.22 • CSA 4.4.

NOTICE! If the relief valve discharges periodically, this may be due to thermal expansion in a closed water supply system. Contact the water supplier or local plumbing inspector on how to correct this situation. Do not plug the relief valve.

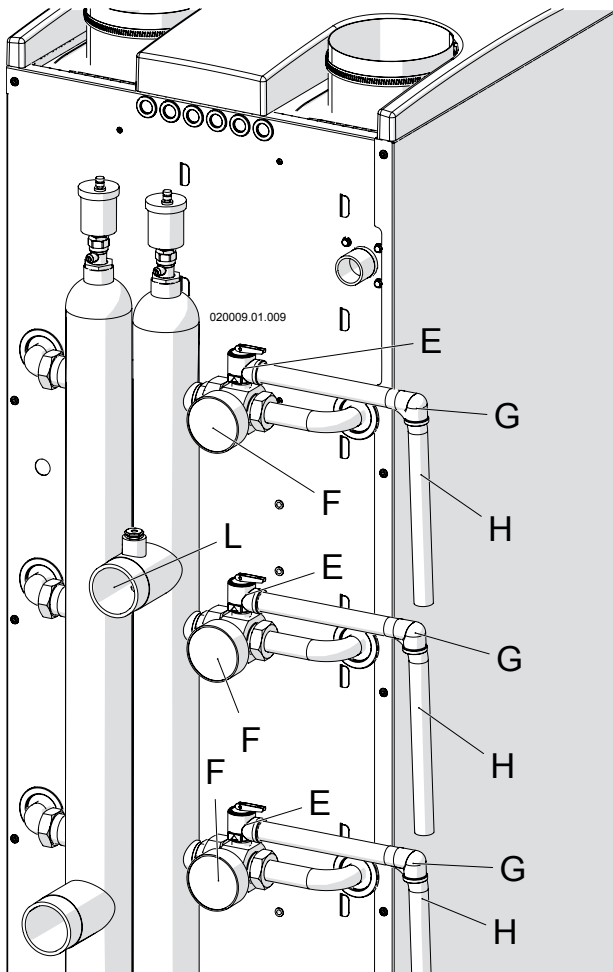

Figure 8-1 Piping of the P-T relief valve discharge

Key to Figure 8-1

- E = ASME Safety Temperature and Pressure relief valve
- F = Temperature and pressure gauge
- G = Elbow (Field supplied)
- H = Relief valve discharge piping (Field supplied)
- L = Hot water outlet

8 - INSTALLATION - IW water connections

8.2.3 - Expansion Tank

If a water heater is installed in a closed water supply system, such as one having a backflow preventer in the cold water supply line, means shall be provided to control thermal expansion. Contact the water supplier or local plumbing inspector on how to control this situation.

Install an expansion tank. Ensure the expansion tank is properly sized for the water volume (See Section 18, header "Content of water") and the system volume, temperature and pressure.

CAUTION!!! Undersized expansion tanks will cause system water to be lost through the relief valve

The expansion tank must be located as shown in Figure 8-4 or as per recognized design methods. Refer to the expansion tank manufacturer instructions for additional installation details.

8.2.4 - Circulator pump

This water heater must be fitted with a circulator pump for domestic hot water. The water resistance of the water heater is shown in graph form in Figure 7-2. To this resistance installer shall add the system water resistance and the storage tank water resistance to size the circulator pump accordingly.

To electrically connect the pump (Local pump) follow Figure 10-5. A field supplied pump relay must be installed if the pump current draw is greater than 3 amps.

8.2.5 - Sizing water system

Size the pump, piping and system components required in the water system, using recognized design methods.

CAUTION!!! It is up to the installer to ensure the minimum water heater flow is not less than the stated on section 18, at any time. If the flow is lower, the unit automatically stops the burner. Minimum water flow must also be sized as per section 8.4

8.2.6 - Anti-legionella

The IW water heater is not protected against the proliferation of the Legionella bacteria. If you don't install any Anti-legionella external system, you have to keep the water temperature inside the tank, at least at 140°F (60°C). This temperature will prevent the proliferation of the legionella bacteria.

WARNING!!! Your domestic hot water system must be protected against legionella bacteria. Failure to comply with this provision can result in severe personal injury or death.

8.3 - Scalding

This water heater can deliver scalding temperature water at any faucet in the system.

Be careful whenever using hot water to avoid scalding injury.

Certain appliances such as dishwashers and washing machines may require increased temperature water.

By setting the water temperature control on this water heater to obtain the increased temperature water required by these appliances, you may create the potential for scald injury.

To protect against injury, you should install a mixing valve in the water system.

This valve will reduce point of discharge temperature by mixing cold and hot water in branch supply lines. Such valves are available from the local plumbing supplier.

Figure 8-2 details the relationship of water temperature and time with regard to scald injury and may be used as a guide in determining the safest water temperature for your applications.

APPROXIMATE TIME / TEMPERATURE RELATIONSHIPS IN SCALDS	
120°F (49°C)	More than 5 minutes
125°F (51°C)	1,5 to 2 minutes
130°F (54°C)	About 30 seconds
135°F (57°C)	About 10 seconds
140°F (60°C)	Less than 5 seconds
145°F (63°C)	Less than 3 seconds
150°F (65°C)	About 1,5 seconds
155°F (68°C)	About 1 second

Figure 8-2 Time / temperature scalds

8 - INSTALLATION - IW water connections

8.4 - Minimum and maximum water flow

The water heater pressure drops (see Figure 7-2) is based on potable water with a hardness of 5 to 17.6 grains per gallon and a total dissolved solids (TDS) not exceeding 310 ppm. Consult the manufacturer when heating potable water exceeding these specifications.

CAUTION!!! Size your water system in a way to respect the minimum water flow in function of the water hardness (See Figure 8-3) to prevent scaling inside the heat exchanger.

Figure 8-3 show an example where you are in possession of a water heater model 1000 and in presence of water with hardness of 16 gr/gal. In this case, as showed by the graph, the minimum water flow is 65 GPM.

CAUTION!!! Water with a hardness of less than 5 grains per gallon will usually have a pH which can be aggressive and corrosive causing damage to the heat exchanger and/or heater piping.

CAUTION!!! Size your water system in a way to never increases above the maximum water flow expected by Figure 8-3 to prevent erosion inside the copper pipes of the appliance.

CAUTION!!! Water quality must be within 6,5 and 8,5 pH acidity value. Values out of this range are corrosive, causing damage to the heat exchanger and/or heater piping.

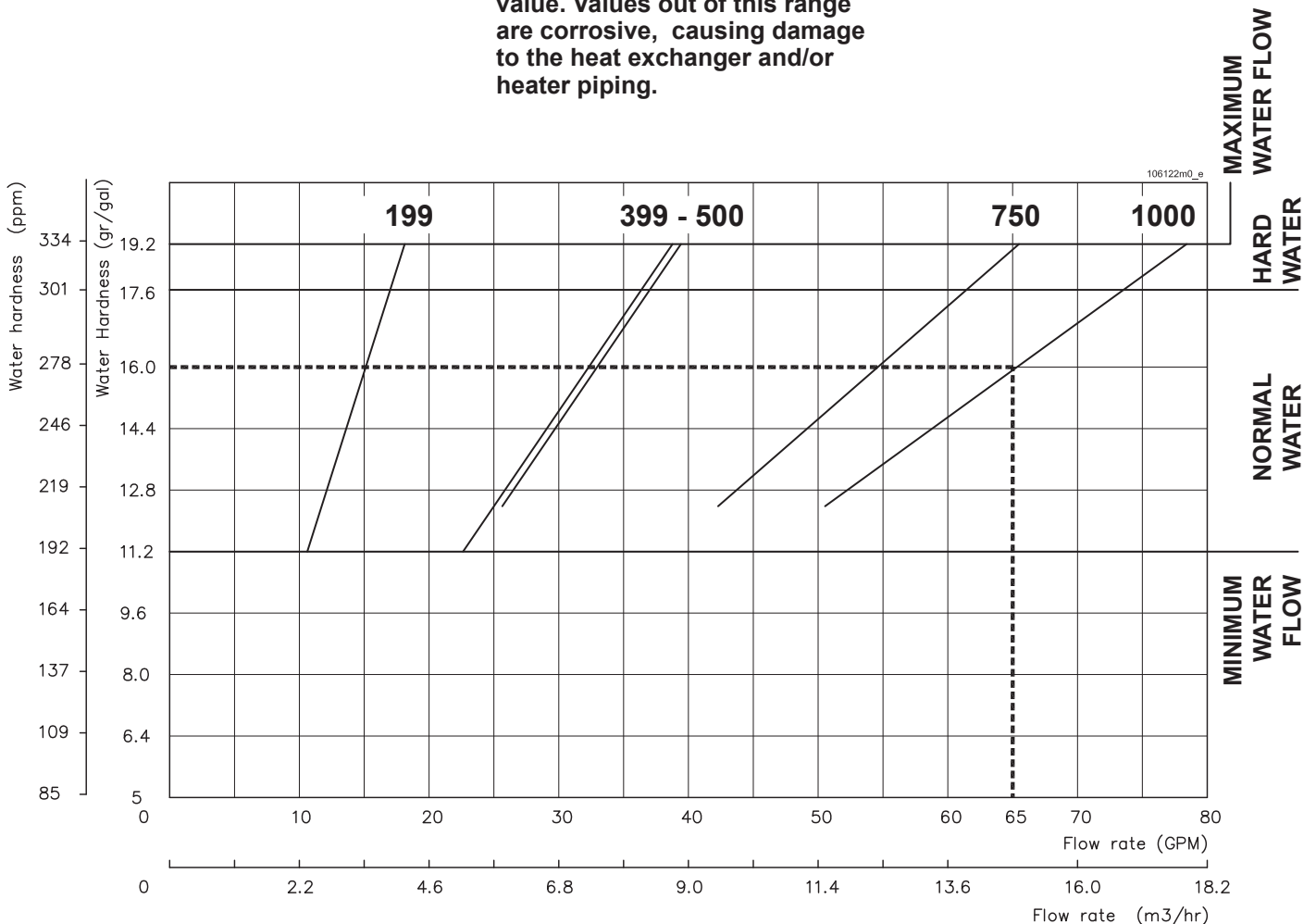
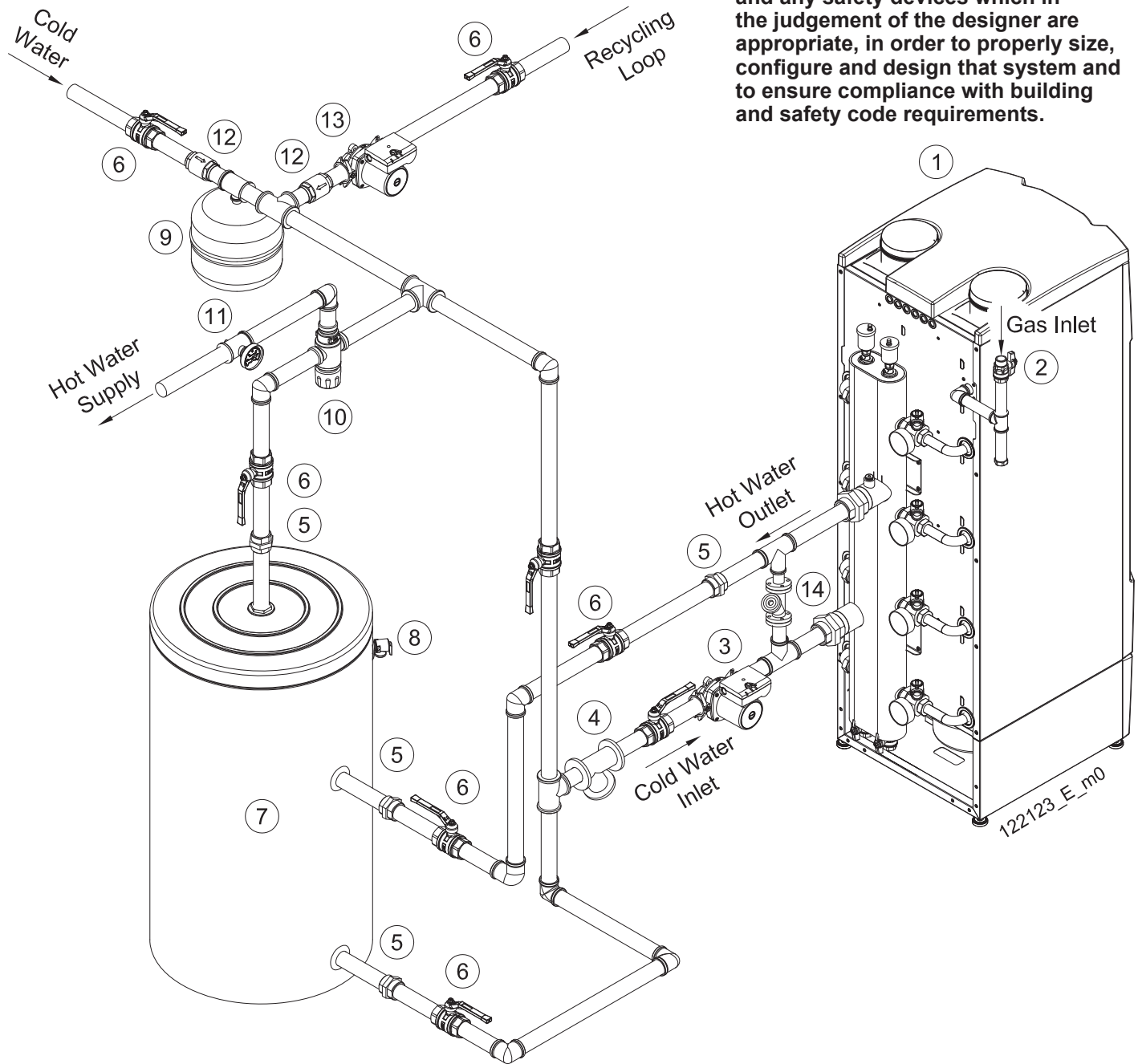

Figure 8-3 Minimum / maximum Water flow in relation to the water hardness

8 - INSTALLATION - IW water connections

CAUTION!!! This is a concept drawing only. It is up to the system designer to determine the necessary components, including additional equipment and any safety devices which in the judgement of the designer are appropriate, in order to properly size, configure and design that system and to ensure compliance with building and safety code requirements.



- 1 = Water heater
- 2 = Manual gas shut-off valve (Install manual gas shut-off valve 5 ft (1.5m) above floor)
- 3 = Storage tank Pump (Local pump)
- 4 = Filter
- 5 = Union
- 6 = Ball valve
- 7 = Storage tank

- 8 = Storage tank T-P relief valve
- 9 = Expansion tank
- 10 = Mixing valve
- 11 = Temperature gauge
- 12 = Check valve
- 13 = Recycling pump (If needed)
- 14 = Balancing valve (mandatory if heater is equipped with motorized valve, item "17" Fig. 3-1)

Figure 8-4 Piping of an IW water heater

9 - INSTALLATION - Condensate disposal

9.1 - Condensate disposal

! WARNING!!! The condensate trap is the same condensate neutralizer box (see Figure 9-1, item "B"). Condensate neutralizer box **MUST** be filled of water or combustion gases will enter the room. This can result in excessive levels of carbon monoxide which can cause severe personal injury or death!

! WARNING!!! The condensate neutralizer box (see Figure 9-1, item "B") **must** be kept within the unit, as shown in Figures 3-3 through 3-11. Removing the condensate neutralizer box from its position may result in combustion gases entering the room. This can result in excessive levels of carbon monoxide which can cause severe personal injury or death!

This heater produces water as a byproduct of combustion. The heater is equipped with a condensate neutralizer box, Figure 9-1, item "B", for the evacuation of condensate and to prevent the leakage of combustion products. The condensate drains through pipe shown in Figure 9-1 item "C" and Figure 9-2 item "A".

Slope condensate tubing down and away from the heater into a drain or drain pan (See Figure 9-2). Condensate from the heater will be slightly acidic (around pH 4). The neutralizing box (see figure 9-1, item "B") will neutralize the condensate products.

CAUTION!!! The condensate discharge line must be of materials approved by the authority having jurisdiction. In the absence of other authority, PVC and CPVC pipe must comply with ASTM D1785 or D2845. Cement and primer must comply with ASME D2564 or F493. For Canada use CSA or ULC certified PVC or CPVC pipe, fittings, and cement.

- ☞ be carried out with a pipe with an internal diameter equal to or greater than $3/4$ in (19 mm);
- ☞ be installed in such a way so as to avoid the freezing of the liquid;
- ☞ never discharge into gutters or rain collectors;
- ☞ be properly pitched towards the point of discharge avoiding high points, which could place the condensate system under pressure.

CAUTION!!! The condensate drainage system is designed to empty all the condensate produced by one heater only. Each heater must be equipped with its own condensate drainage system or the drainage system may malfunction.

A condensate removal pump is required if the heater is below the drain. When installing a condensate pump, select one approved for use with condensing heaters and furnaces. The pump should have an overflow switch to prevent property damage from condensate spillage.

COMMONWEALTH OF MASSACHUSETTS SPECIAL REQUIREMENT

This heater meet the special requirement of the Commonwealth of Massachusetts, because the neutralization unit is already installed within the heater.

9 - INSTALLATION - Condensate disposal

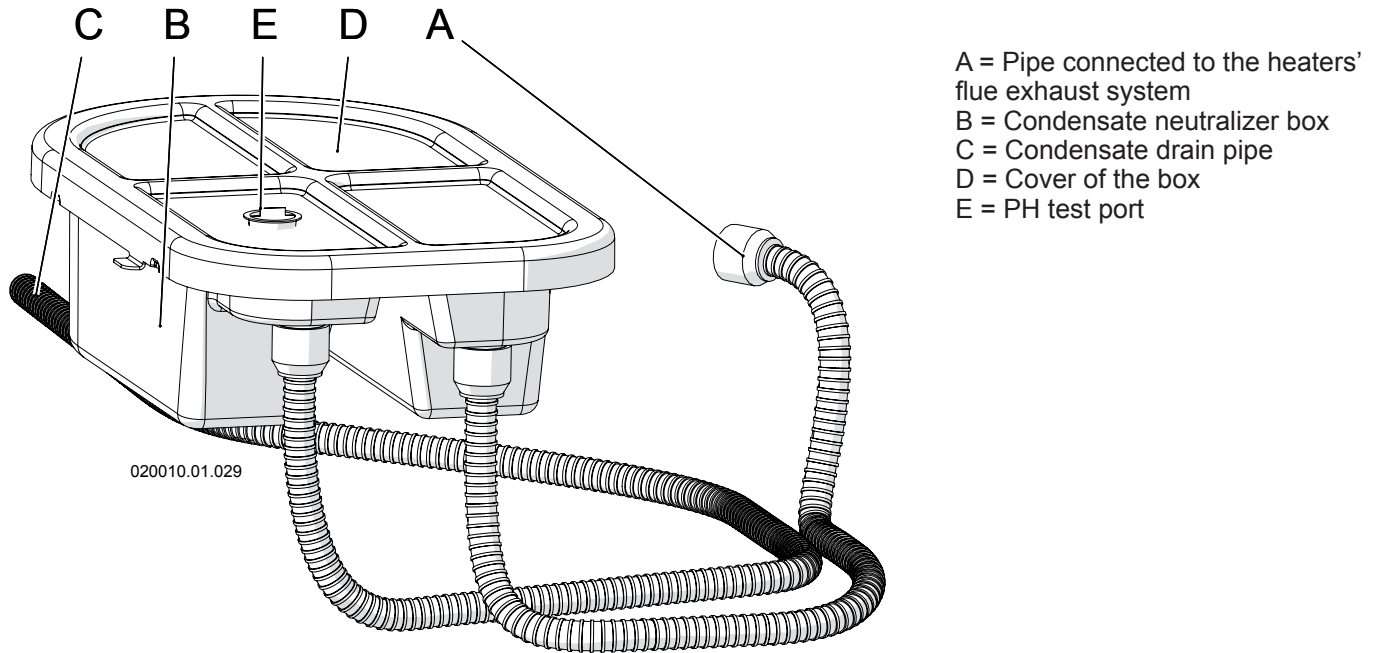
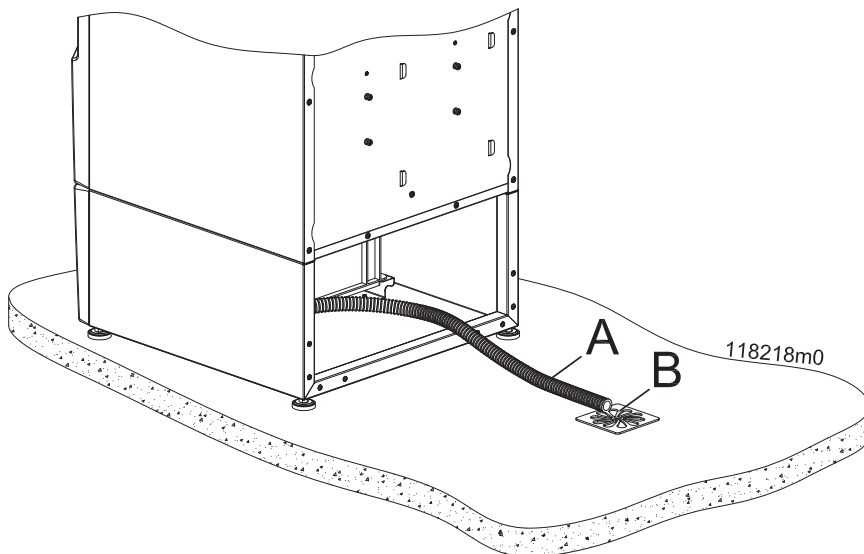
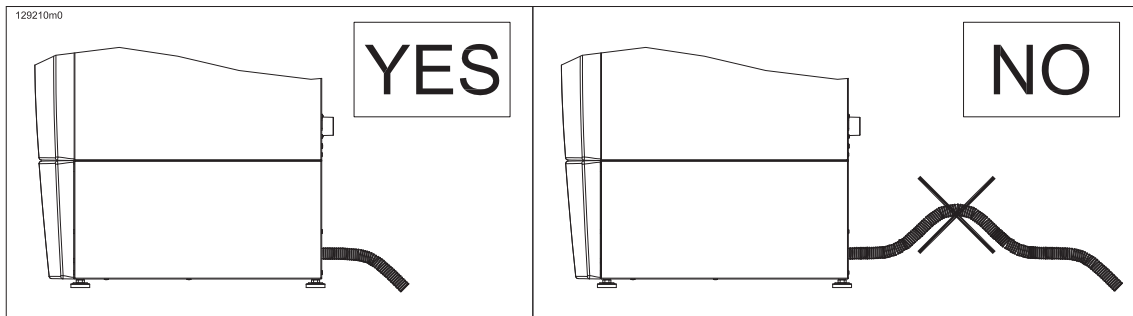

Figure 9-1 Condensate neutralizer box (see also Figures 3-3 through 3-11, Item 3)



A = Condensate drain pipe
 B = Floor drain or drain pan (Below this point there must be a trap capable of preventing the return of sewer gas)

Figure 9-2 Condensate pipe and drain

10 - INSTALLATION - Electrical connections

10.1 - Electrical connections: overview

WARNING!!! ELECTRICAL

SHOCK HAZARD Turn off electrical power supply before making any electrical connections to avoid possible electric shock hazard. Failure to do so can cause severe personal injury or death.

WARNING!!! Label all

wires prior to disconnection when servicing controls. Wiring errors can cause improper and dangerous operation, severe personal injury or death. Be sure of a correct functioning after the servicing.

 **ATTENTION!!!** *Au moment de l'entretien des commandes, étiquetez tous les fils avant de les débrancher. Des erreurs de câblage peuvent entraîner un fonctionnement inadéquat et dangereux. S'assurer que l'appareil fonctionne adéquatement une fois l'entretien terminé.*

 **WARNING!!!** The heater must be electrically wired to ground in accordance with the requirements of the authority having jurisdiction or, in the absence of such requirements, with the *National Electrical Code, ANSI/NFPA 70* and/or the *Canadian Electrical Code Part I, CSA C22.1, Electrical Code*.

NOTICE! Wiring must be N.E.C. Class 1. Use only type 105°C wire or equivalent.

Installation must comply with:

1. National Electrical Code and any other national, state, provincial, or local codes, or regulations.
2. In Canada, CSA C22.1 Canadian Electrical Code Part 1, and any local codes.

- ☞ Check that the electrical system is adequate for the power consumption indicated on the rating plate or in Section 18.
- ☞ Line voltage field wiring of any controls or other devices must conform to the temperature limitation of type T wire at 95 °F (35 °C), above room temperature. Use copper conductors with a minimum size of #14 AWG. Low voltage wiring must not be less than #18 AWG with a neoprene, thermoplastic or other equivalent insulation having a minimum insulation thickness of 0.012 in, (0.3 mm).
- ☞ A properly rated shut-off switch shall be located nearest to the heater for any maintenance use.
- ☞ Ensure that the polarity between live and neutral wires is maintained when connecting the heater.

CAUTION!!! Ensure that heating and water piping is not used as a ground connections for the electric and telephone systems. This piping is completely unsuitable for this purpose and could rapidly lead to serious corrosion damage to the heater, piping and radiators.

CAUTION!!! The heater is not provided with any protection against lightning strikes.

10 - INSTALLATION - Electrical connections

10.1.1 - Connecting the power supply cable

Provide and install a fused disconnect or service switch (15 amp recommended) as required by the code. To connect the electrical power supply cable, follow the steps below while referring to Figures 10-1, 10-4 or 10-5:

1. remove the heater casing following the instructions given in Section 17.2 and open the junction box cover;
2. install the power supply wires, "B" and "C" to terminals "101" and "102". connect the ground wire to the ground terminal;
3. connect the 120 volt hot wire to terminal "101";
4. connect the 120 volt neutral wire to terminal "102".

NOTICE! If the 120 volt power wires are inverted, the heater will block, displaying error code Err 65.

10.1.2 - Room Thermostat wiring (IB Boiler only)

Install the room thermostat in a part of the house where the temperature is as near to average as possible. Avoid areas subject to sudden temperature changes such as outside windows or doors, above radiation elements, near lamps, etc., (see Figure 10-2).

Connect the room thermostat to the boiler by following the steps below:

1. remove the boiler casing according to

- the instructions given in Section 17.2 and open the junction box cover;
2. use a two conductor cable with a minimum cross section of #18 AWG between the boiler and the room thermostat;
3. connect the cable leads to the "10" and "11" terminals as shown in Figure 10-4.

NOTICE! The maximum room thermostat cable length permitted is 32 ft (10 m). For longer lengths, up to 300ft (100 m) a shielded cable, with the shield connected to the ground, must be used.

! WARNING!!! Since the room thermostat wires conduct 24 Vac, they must never run through conduits containing 120Vac power wires or an electrical shock hazard will exist.

10.1.3 - Installing the outdoor temperature sensor (IB Boiler only)

The outdoor temperature sensor is supplied with the boiler. Install the outdoor temperature sensor, on an exterior wall of the building facing NORTH or NORTH-EAST, at a height of between 4 ft (1.2 m) and 6 ft (1.8 m) from the ground level. On multi story buildings, install the sensor near the upper half of the second floor. Do not install the sensor above doors, windows

or ventilation outlets nor directly under balconies or gutter pipes. Do not shield the outdoor temperature sensor. Do not install the sensor on walls without overhangs, or not protected from rain. Connect the outdoor temperature sensor to the boiler to terminals "14" and "15" (See figure 10-4):

1. use a two conductor cable with a minimum cross section of # 18 AWG between the boiler and the outdoor temperature sensor.

NOTICE! The maximum outdoor temperature sensor cable length permitted is 32 ft (10 m). For longer lengths, up to 300 ft (100 m) a shielded cable, with the shield connected to the ground, must be used;

! WARNING!!! Since the outdoor temperature sensor wires conduct 24 Vac, they must never run through conduits containing 120 Vac power wires or an electrical shock hazard will exist.

2. connect the outdoor temperature sensor cable leads to the ends of the external temperature sensor.

Set the boiler so that it detects the outdoor temperature sensor, as follows:

1. Gain access to the installers' menu (see Section 16.14);
2. Set parameter 2003 to 1.

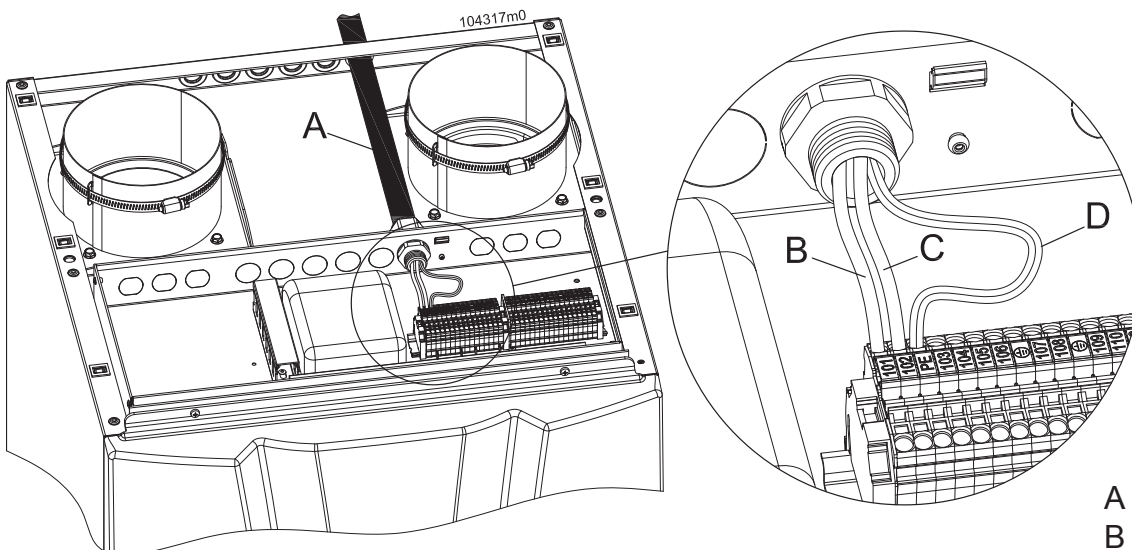

A = Cable conduit
 B = Line (Hot) cable
 C = Neutral cable
 D = Ground cable

Figure 10-1 Junction box

10 - INSTALLATION - Electrical connections

10.1.4 - Connection to an analog Vcc input

On appliances model 399, 500, 750 and 1000 it is factory supplied the 885IF board that permit installer to drive the unit via a Vcc input (199 model can be equipped on demand). To do this, you have to connect the Vcc supply between terminals 22 and 23 (see Figures 10-4 and 10-5). Also, the CH mode (parameter 2003 as per Section 16.14) must be set to 4 value.

Now the heater can start to receive the analog input Vcc and it will control the supply temperature under the rules as explained in Figure 10-3 where:

- if the input voltage is growing up to 1.5V, the heater stay OFF;
- if the input voltage move between 1.5V and 2.0V the heater start to work and the supply temperature stay at the value set on parameter 3018 (Minimum CH setpoint, see Section 21);

- if the input voltage move between 2V and 10V, the supply temperature will change proportionally between the Minimum CH setpoint (parameter 3018, see Section 21) and the Maximum CH setpoint (parameter 3017, see Section 21).

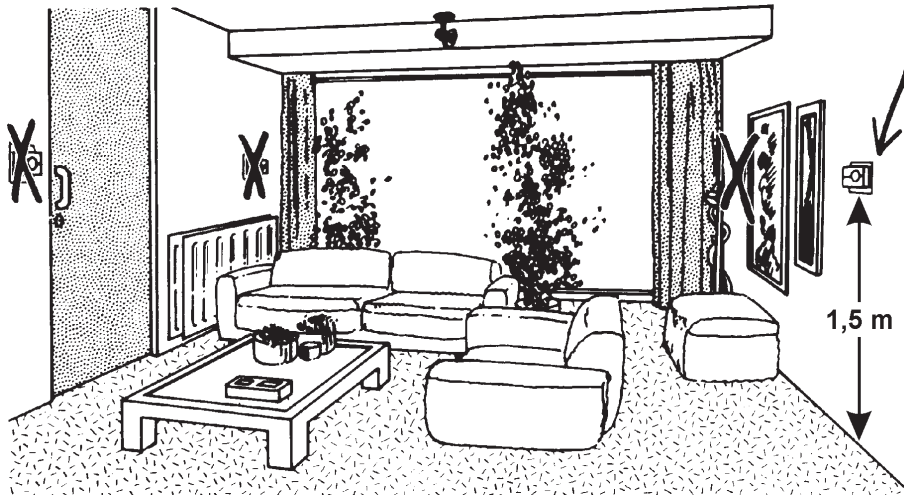

Figure 10-2 Room thermostat location

10.1.5 - Connection to a MODBUS protocol

On appliances model 399, 500, 750 and 1000 it is factory supplied the 885IF board that has an integrated MODBUS protocol (199 model can be equipped on demand).

This 885IF board with the MODBUS protocol can be connected to drive the unit from a building management device. Instructions on how to connect the MODBUS protocol are supplied on demand.

10.1.6 - Connection to a LWCO device

CAUTION!!! Use only LWCO sensor device. To use water flow switch ask engineering wiring diagram to the manufacturer. Install LWCO device as per engineering method. Connect LWCO terminals to 103 and 104 heater terminals.

WARNING!!! Heater terminals 103 and 104 containing line voltage and electrical shock hazard will exist.

10.1.7 - Alarm contact

Alarm contact works only in presence of the 885 IF board (see figures 3-3, 3-6 and 3-9, item 13). Alarm contact does not react in case a dependent module (burner 2, 3 or 4) is in error.

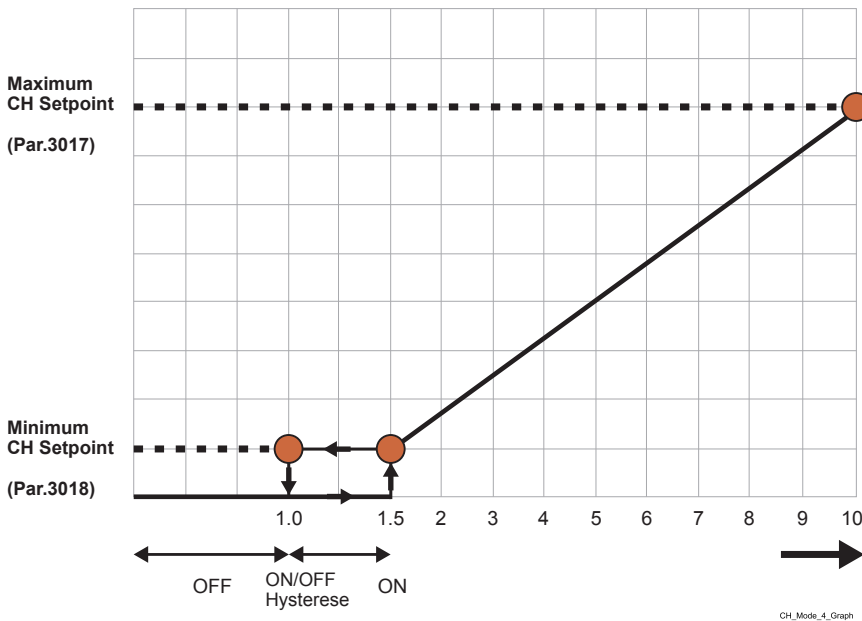

Figure 10-3 Vcc analog input algorithm

10 - INSTALLATION - Electrical connections

10.2 - Connecting the IB boiler to an indirect water heater

This boiler, can be connected to an indirect water heater as follows:

1. The water connection must be made per Figure 7-3
2. The indirect water heater pump (DHW pump) must be connected to terminals “107” and “108” (See Figure 10-4); a field supplied pump relay must be installed if the pump current draw is greater than 3 amps as indicated in Figure 10-4.
3. The indirect water heater temperature sensor (Tank sensor) must be connected to terminals “12” and “13” (See Figure 10-4).
The sensor must be placed into the indirect water heater in a way that can detect its water temperature (Follow the indirect water heater instruction).
4. Set the boiler so that it detects the indirect water heater sensor, as follows:
 - a. Gain access to the Factory menu (see Section 21);
 - b. Set parameter 3012 to 1.

Follow Section 16.6 to set the desired indirect water heater temperature.

! WARNING!!! Since the indirect water heater temperature sensor wires conduct 24 Vac, they must never run through conduits containing 120 Vac power wires or an electrical shock hazard will exist.

10.2.1 Indirect water heater priority selection

The boiler is factory set for DHW priority. This means that the boiler will stay in DHW mode until the capacity of the indirect water heater reaches temperature. In some cases this will result in the house cooling because the central heating function was stopped by the DHW priority mode. Once the indirect water heater is satisfied the boiler will automatically return to central heating.

Priority selection is a functionality that toggles between CH and DHW demand when they are both active at the same time. The priority selection is set with the 2067 (DHW Priority) parameter in the “Installers’ menu” (see Section 16.14).

If parameter 2067 is set to “0” and a call for heat and domestic water are present at the same time, the boiler will give priority to the indirect water heater for the time period specified in parameter 2063. At the end of that time period, the boiler will switch to heating priority for the length of time specified in parameter 2063. If a call for domestic operation is still present the boiler will switch back to priority mode for the indirect for the time specified in parameter 2063.

If parameter 2067 is set to “1” the boiler will give priority to heating only.

If parameter 2067 is set to “2” the boiler will give priority to indirect water heater only.

10.3 - Connecting the IW water heater to a storage tank

The water heater must be connected to a storage tank:

1. The water connection must be made per Figure 8-4.
2. The storage tank pump (Local pump) must be connected to terminals “113” and “114” (See Figure 10-5) (a field supplied pump relay must be installed if the pump current draw is greater than 3 amps).
3. Remove header sensor present on terminals “8” and “9” of Figure 10-5;
4. The storage tank temperature sensor must be connected to terminals “8” and “9” (See Figure 10-5). The sensor must be placed into the storage tank in a way that can detect the water temperature (Follow the storage tank instruction).

Follow Section 16.5 to set the desired storage tank temperature.

! WARNING!!! Since the storage tank temperature sensor wires conduct 24 Vac, they must never run through conduits containing 120 Vac power wires or an electrical shock hazard will exist.

10 - INSTALLATION - Electrical connections

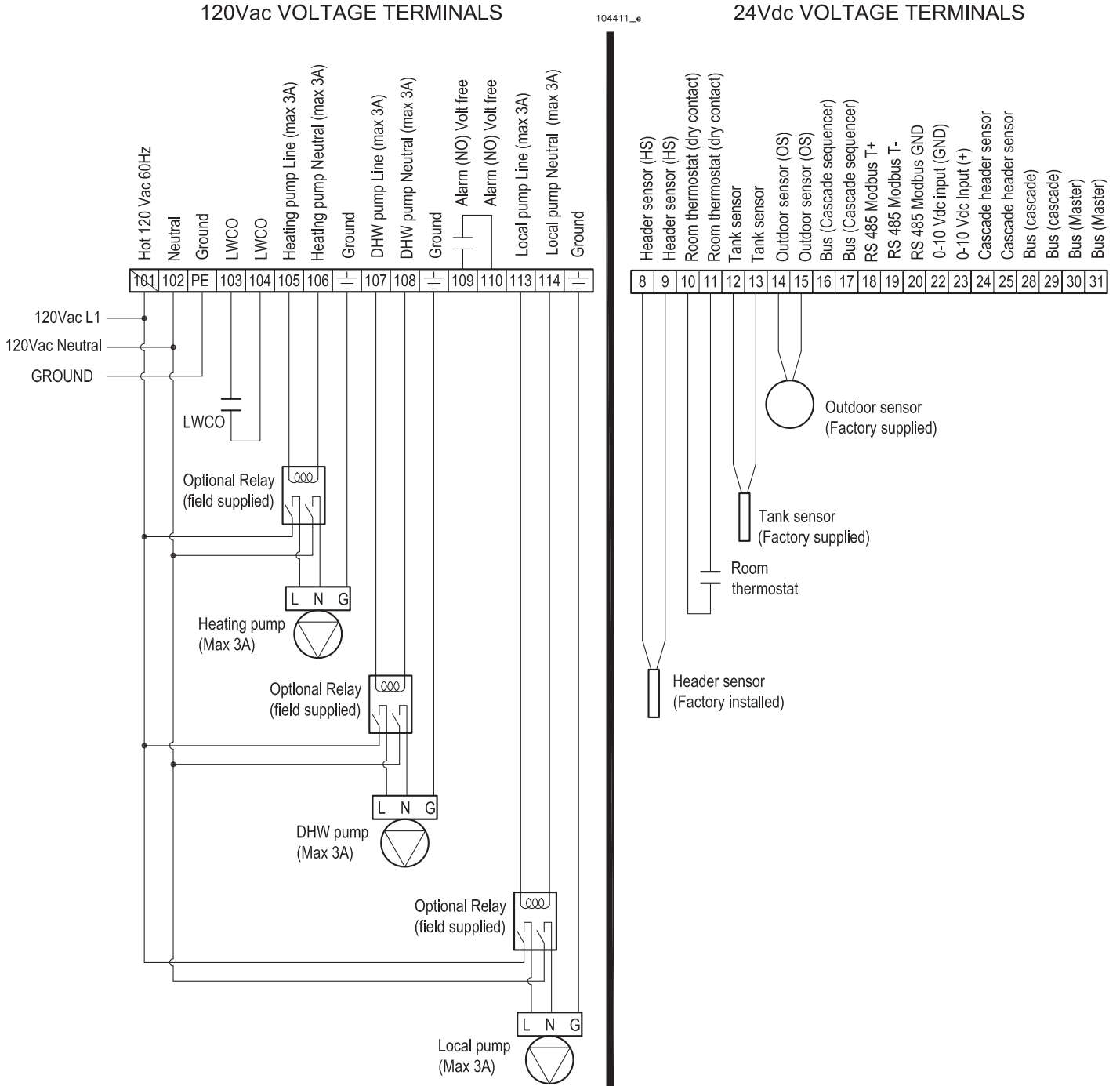

Figure 10-4 Electrical customer connection for IB boilers

10 - INSTALLATION - Electrical connections

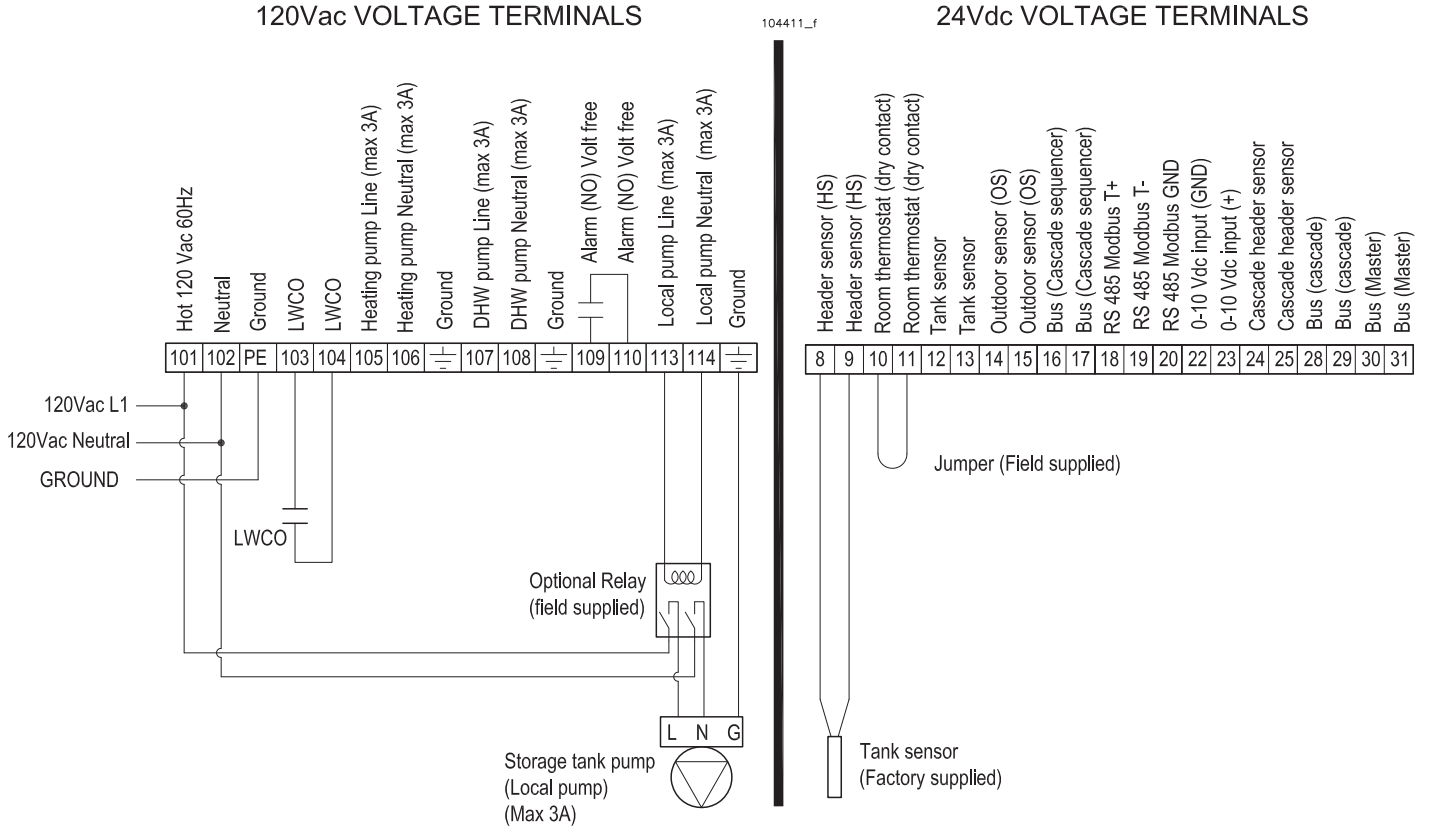

Figure 10-5 Electrical customer connection for IW water heaters

10 - INSTALLATION - Electrical connections

10.4 - Connecting the heater in cascade

Heaters can be installed in cascade with a configuration like in Figure 10-7. Many other configurations can be done (ask to the heater manufacturer for conceptual drawings). The cascade is managed by the 885HC cascade manager command that is supplied on demand.

Operative instructions on how to connect the heaters in cascade are supplied together the 885HC command.

For water, gas, flue exhaust and air intake connections, ask for conceptual drawings to the manufacturer.

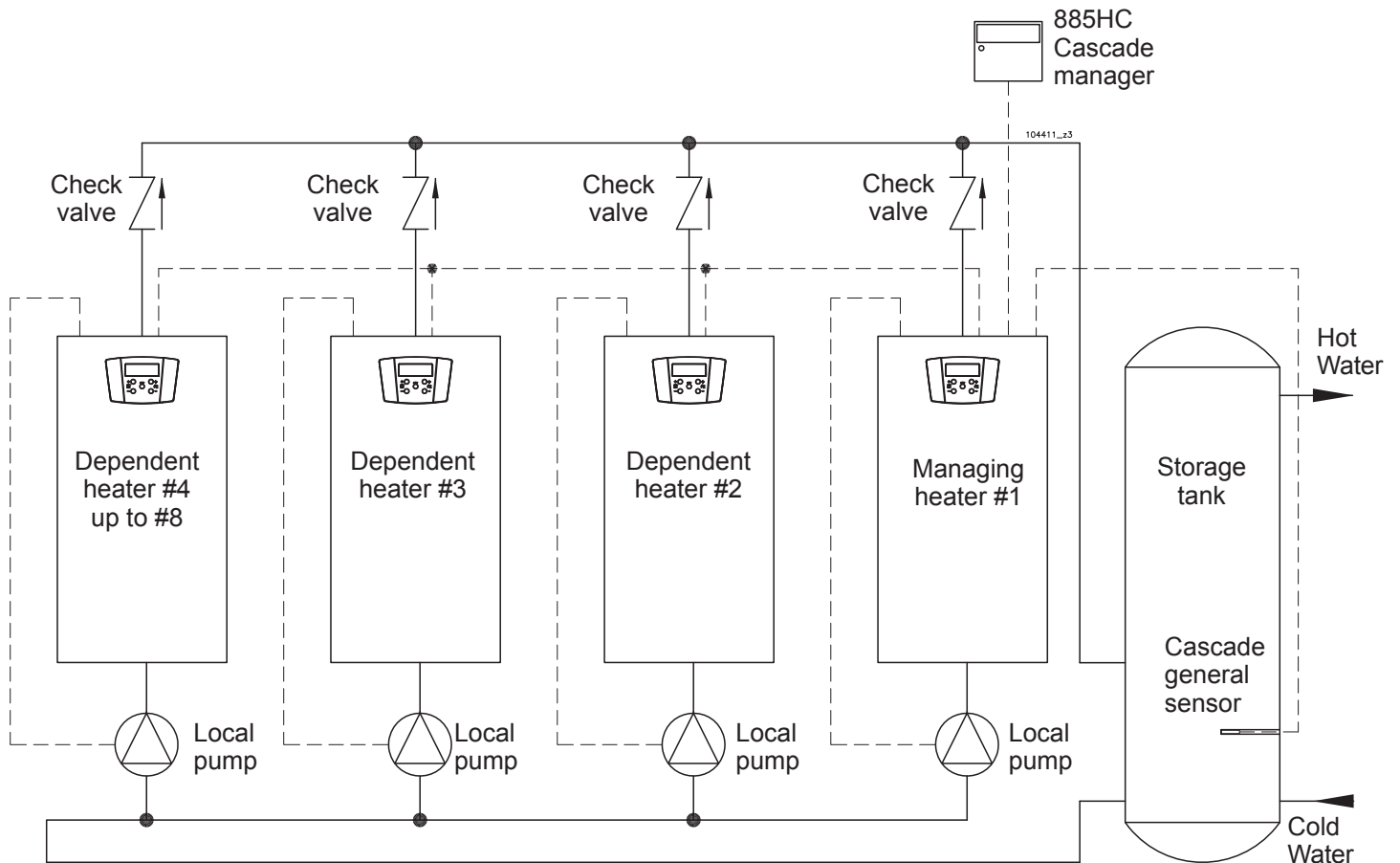

Figure 10-6 Cascade (water heaters) conceptual scheme

10 - INSTALLATION - Electrical connections

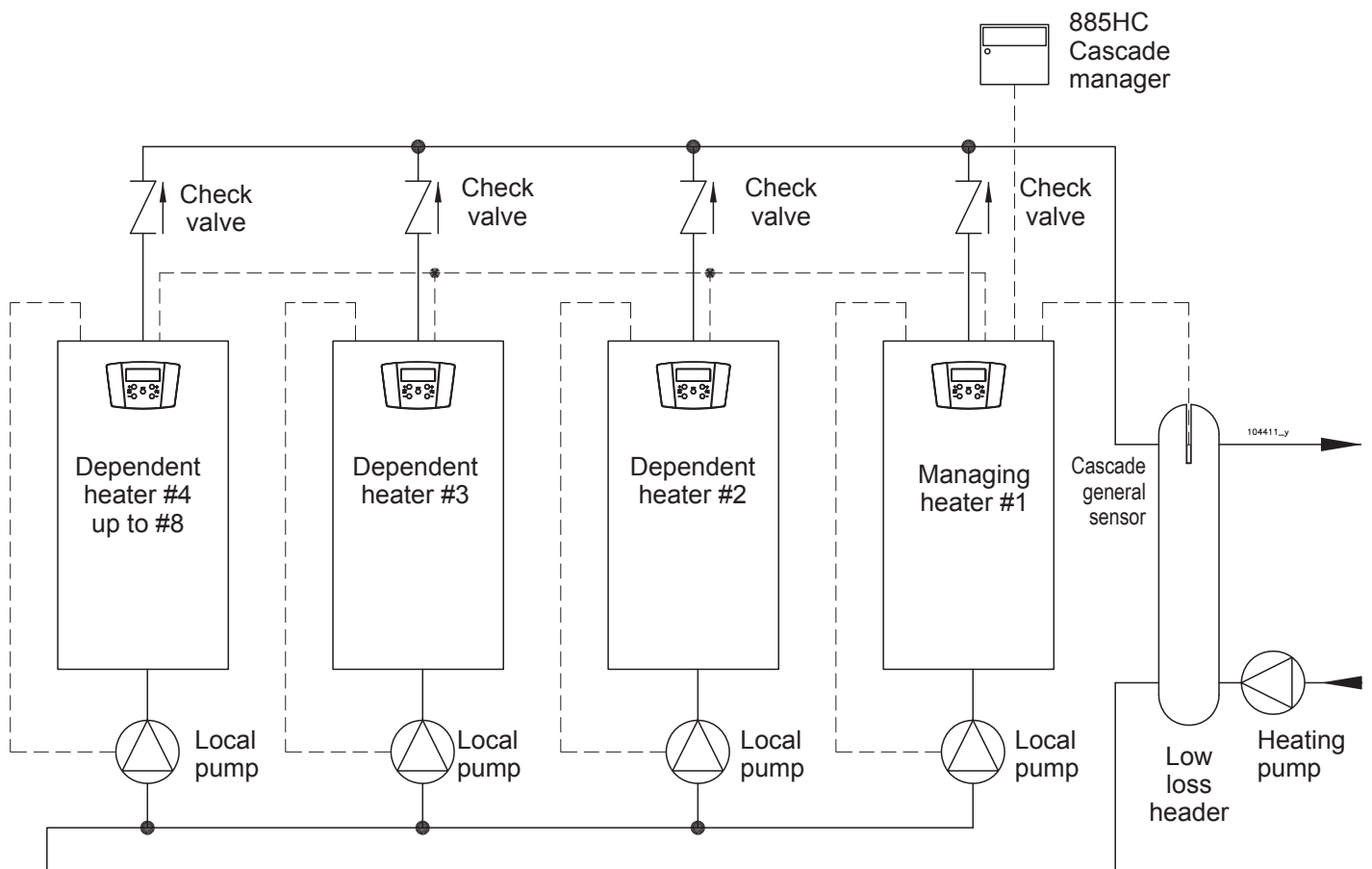

Figure 10-7 Cascade (boilers) conceptual scheme

11 - INSTALLATION - Removing of an heater from a common venting system

11.1 - Removing of a heater from a common venting system

! WARNING!!! DO NOT connect this heater or any other appliance using a positive pressure, in a common vent system! Failure to comply with this WARNING could result in the accumulation of carbon monoxide gas which can cause severe personal injury or death!

When an existing heater is removed from a common venting system, the common venting system is likely to be too large for proper venting of the appliances remaining connected to it. At the time of removal of an existing heater, the following steps shall be followed with each appliance remaining connected to the common venting system placed in operation, while the other appliances remaining connected to the common venting system are not in operation.

- (a) Seal any unused openings in the common venting system.
- (b) Visually inspect the venting system for proper size and horizontal pitch and determine there is no blockage or restriction, leakage, corrosion and other deficiencies which could cause an unsafe condition.
- (c) Insofar as is practical, close all building doors and windows and all doors between the space in which the appliances remaining connected to the common venting system are located and other spaces of the building. Turn on clothes dryers and any appliance not connected to the common venting system. Turn on any exhaust fans, such as range hoods and bathroom exhausts, so they will operate at maximum speed. Do not operate a summer exhaust fan. Close fireplace dampers.

- (d) Place in operation the appliance being inspected. Follow the lighting instructions. Adjust thermostat so appliance will operate continuously.
- (e) Test for spillage at the draft hood relief opening after 5 minutes of main burner operation. Use the flame of a match or candle, or smoke from a cigarette, cigar or pipe.
- (f) Alter it has been determined that each appliance remaining connected to the common venting system properly vents when tested as outlined above, return doors, windows, exhaust fans, fireplace dampers and any other gas-burning appliance to their previous condition of use.
- (g) Any improper operation of the common venting system should be corrected so the installation conforms with the National Fuel Gas Code, ANSI Z223.1 /NFPA 54 and/or CAN/CSA B149.1, Natural Gas and Propane Installation Code. When resizing any portion of the common venting system, the common venting system should be resized to approach the minimum size as determined using the appropriate Annex G of the National Fuel Gas Code, ANSI Z223.1 /NFPA 54 and/or CAN/CSA B149.1, Natural Gas and Propane Installation Code.

Au moment du retrait d'une chaudière existante, les mesures suivantes doivent être prises pour chaque appareil toujours raccordé au système d'évacuation commun et qui fonctionne alors que d'autres appareils toujours raccordés au système d'évacuation ne fonctionnent pas: système d'évacuation

- (a) *Sceller toutes les ouvertures non utilisées du système d'évacuation.*
- (b) *Inspecter de façon visuelle le système d'évacuation pour déterminer la grosseur et l'inclinaison horizontale qui conviennent et s'assurer que le système est exempt d'obstruction, d'étranglement de fuite, de corrosion et autres défaillances qui pourraient présenter des risques.*

- (c) *Dans la mesure du possible, fermer toutes les portes et les fenêtres du bâtiment et toutes les portes entre l'espace où les appareils toujours raccordés du système d'évacuation sont installés et les autres espaces du bâtiment. Mettre en marche les sècheuses, tous les appareils non raccordés au système d'évacuation commun et tous les ventilateurs d'extraction comme les hottes de cuisinière et les ventilateurs des salles de bain. S'assurer que ces ventilateurs fonctionnent à la vitesse maximale. Ne pas faire fonctionner les ventilateurs d'été. Fermer les registres des cheminées.*
- (d) *Mettre l'appareil inspecté en marche. Suivre les instructions d'allumage. Régler le thermostat de façon que l'appareil fonctionne de façon continue.*
- (e) *Faire fonctionner le brûleur principal pendant 5 min ensuite, déterminer si le coupe-tirage déborde à l'ouverture de décharge. Utiliser la flamme d'une allumette ou d'une chandelle ou la fumée d'une cigarette, d'un cigare ou d'une pipe.*
- (f) *Une fois qu'il a été déterminé, selon la méthode indiquée ci-dessus, que chaque appareil raccordé au système d'évacuation est mis à l'air libre de façon adéquate. Remettre les portes et les fenêtres, les ventilateurs, les registres de cheminées et les appareils au gaz à leur position originale.*
- (g) *Tout mauvais fonctionnement du système d'évacuation commun devrait être corrigé de façon que l'installation soit conforme au National Fuel Gas Code, ANSI Z223.1/NFPA 54 et (ou) aux codes d'installation CSA-B149.1. Si la grosseur d'une section du système d'évacuation doit être modifiée, le système devrait être modifié pour respecter les valeurs minimales des tableaux pertinents de l'appendice G du National Fuel Gas Code, ANSI Z223.1/ NFPA 54 et (ou) des codes d'installation CSA-B149.1.*

12 - INSTALLATION - CATEGORY IV: Vent and combustion air

12.1 - CATEGORY IV: Positive pressure condensing

An appliance that operates with a positive vent static pressure with a vent gas temperature that may cause condensate production in the vent.

12.2 - CATEGORY IV: Venting and air piping systems

! WARNING!!! The vent installation must be in accordance with part *Venting of Appliances*, of the latest edition of the *National Fuel Gas Code*, ANSI Z223.1/NFPA 54 or section, *Venting Systems and Air Supply for Appliances*, of the *CAN/CSA B149.1, Natural Gas and Propane Installation code* or applicable provisions of the local building codes. Improper venting can result in excessive levels of carbon monoxide which can result in severe personal injury or death!

! WARNING!!! All vent pipes must be mechanically fixed. Improper venting can result in excessive levels of carbon monoxide which can result in severe personal injury or death!

! WARNING!!! The exhaust vent and the air inlet lines, must be supported to prevent sagging. To do this, use a suitable pipe clamp to support the lines. Pipe clamps shall support the line every 3 ft (1 m). Pipe clamp shall be fixed in correspondance of a wall stud. Improper supporting can result in excessive levels of carbon monoxide which can result in severe personal injury or death!

NOTICE! The exhaust pipe must be pitched a minimum of a 1/4 inch per foot back to the heater (to allow drainage of condensate).

NOTICE! The vent system shall be installed so as to prevent the accumulation of condensate.

NOTICE! Due to the high efficiency of the heater it may discharge what looks like white smoke especially when the outside air temperature is cold. This is a simply water vapor, a purely natural phenomenon and not a reason for concern.

This heater requires a special vent system, designed for pressurized venting.

You must install air piping from outside to the heater air intake. The resultant installation is Direct Vent (sealed combustion).

The heater is to be used for either Direct Vent installation or for installation using room combustion air. When room air is considered, see Section 12.9.

Vent and air must terminate near one another and may be vented vertically through the roof or out a side wall, unless otherwise specified. You may use any of the vent/air piping methods from Figure 12-1 to Figure 12-6. Do not attempt to install this heater using any other means.

! WARNING!!! DO NOT mix components from different systems. The vent system could fail, causing leakage of flue products into the living space. Use only approved materials listed on Figures 12-7 and 12-8. Improper materials or mixing materials can result in excessive levels of carbon monoxide which can result in severe personal injury or death!

! WARNING!!! Use of cellular core PVC and CPVC or Radel for venting system is not allowed. Use of improper materials can result in excessive levels of carbon monoxide which can result in severe personal injury or death!

Be sure to locate the heater such that the vent and air piping can be routed through the building and properly terminated.

The vent/air piping lengths, routing and termination method must all comply with the methods and limits given in Section 12.3.

12 - INSTALLATION - CATEGORY IV: Vent and combustion air

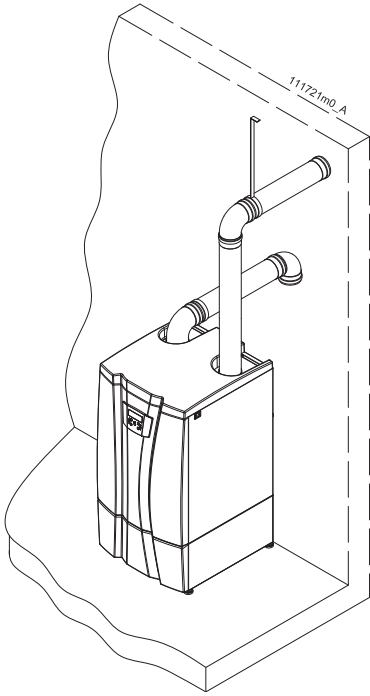

Figure 12-1 Side wall two pipes (Direct venting).

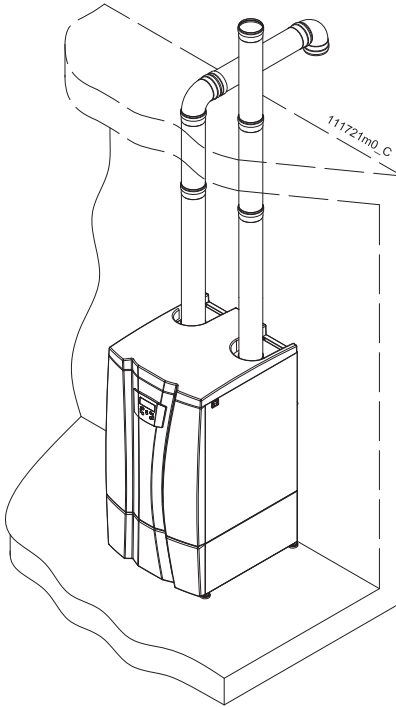

Figure 12-2 Vertical two pipes (Direct Venting).

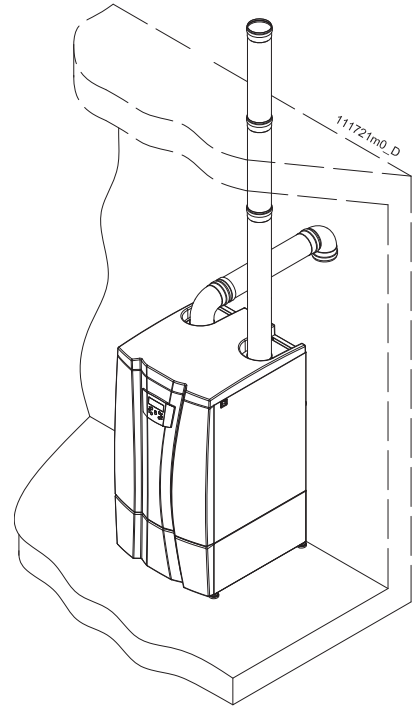

Figure 12-3 Side wall air intake, vertical vent (Direct venting).

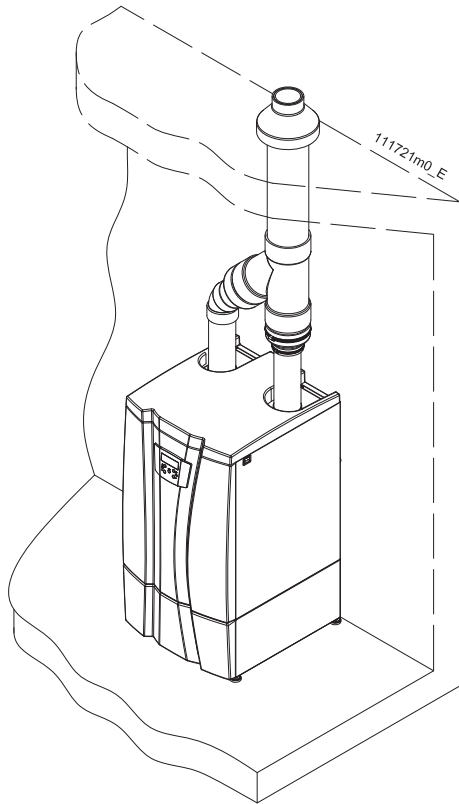

Figure 12-4 Vertical concentric (Direct venting).

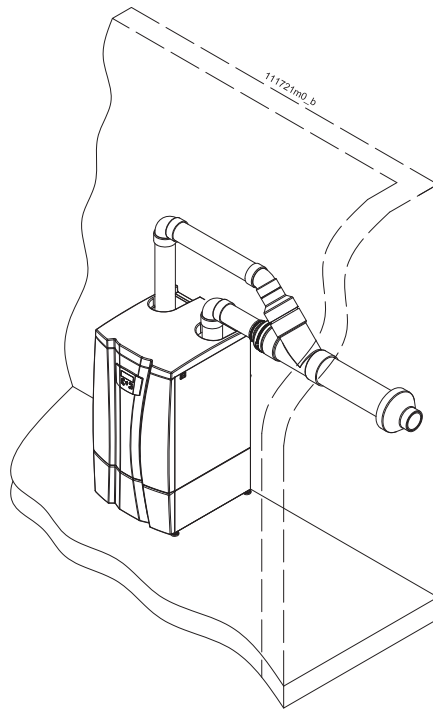

Figure 12-5 Side wall concentric (Direct venting).

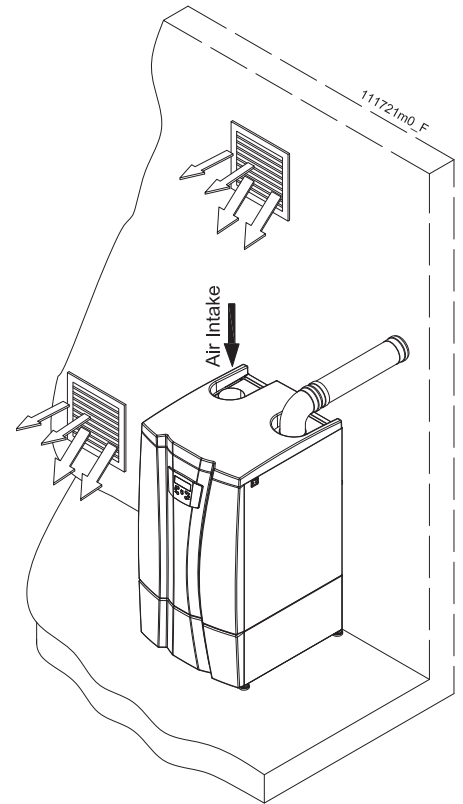

Figure 12-6 Side wall (or vertical in a roof) one pipe venting, combustion air from room (not Direct venting).

12 - INSTALLATION - CATEGORY IV: Vent and combustion air

12.3 - Minimum / Maximum allowable combustion air and vent piping lengths

The maximum length of the two pipes vent system is 120 equivalent ft (Air intake plus flue exhaust). However, each single pipe can't be longer than 60 ft.

Each 45° elbow inserted in the venting system, has a loss of pressure equivalent to 3 ft of linear pipe.

Each 90° elbow inserted in the venting system, has a loss of pressure equivalent to 6 ft of linear pipe.

The minimum length of the venting system is 1 ft (357 mm).

12.4 - Install vent and combustion air piping

! WARNING!!! This heater must be vented and supplied with combustion and ventilation air as described in this section. Ensure the vent and air piping and the combustion air supply comply with these instructions regarding vent system, air system, and combustion air quality. See also Section 5.1.1 of this manual. Inspect finished vent and air piping thoroughly to ensure all are airtight and comply with the instructions provided and with all requirements of all applicable codes. Failure to provide a properly installed vent and air system will cause severe personal injury or death.

! WARNING!!! Using vent materials other than those listed in Figure 12-7 and Figure 12-8, failure to properly seal all seams and joints, mixing

of venting materials or failure to follow vent pipe and fittings manufacturer's instructions can result in personal injury, death or property damage.

! WARNING!!! Use of cellular core PVC and CPVC or Radel for venting system is not allowed. Use of improper materials can result in excessive levels of carbon monoxide which can result in severe personal injury or death!

! WARNING!!! Use only the materials listed in Figure 12-7 and Figure 12-8 for vent pipe, and fittings. Failure to comply could result in severe personal injury, death, or substantial property damage.

NOTICE! Installation must comply with local requirements and with the National Fuel Gas Code, ANSI Z223.1 for U.S. installations or CSA B149.1 for Canadian installations.

For installation in Canada, vent pipe system must be certified to ULC-S636 (see Figure 12-7).

Vent pipe materials and fittings must comply with the following standards			
Item	Material	Standard for installation in USA	Standard for installation in CANADA
Vent pipe	PVC schedule 40/80	ANSI/ASTM D2665	ULC-S636
	CPVC schedule 40/80	ANSI/ASTM F441	
	Polypropylene	ULC-S636	
	Stainless steel AL29-4C	UL 1738	
Vent fittings	PVC schedule 40	ANSI/ASTM D2466	
	PVC schedule 80	ANSI/ASTM D2467	
	CPVC schedule 80	ANSI/ASTM F439	
	Polypropylene	ULC-S636	
	Stainless steel AL29-4C	UL 1738	
Pipe cement/primer	PVC	ANSI/ASTM D2564	
	CPVC	ANSI/ASTM F493	

! WARNING!!! Use of cellular core PVC, CPVC, and Radel for venting system is not allowed

Figure 12-7 Approved vent materials

12 - INSTALLATION - CATEGORY IV: Vent and combustion air

Approved vent manufacturers and items				
Item	Family of the Material	Manufacturer/ supplier	Applicable to models	Manufactur. Part Number
3" Concentric roof or wall terminal	PVC	IPEX (System 636)	199	196006
4" Concentric roof or wall terminal	PVC	IPEX (System 636)	399, 500	196021
3" Concentric roof or wall terminal	CPVC	IPEX (System 636)	199	197009
4" Concentric roof or wall terminal	CPVC	IPEX (System 636)	399, 500	197021
3" Two (and single) pipes roof or wall terminal (90° elb.)	PVC	IPEX (System 636)	199	196025
4" Two (and single) pipes roof or wall terminal (90° elb.)	PVC	IPEX (System 636)	399, 500	196124
3" Two (and single) pipes roof or wall terminal (90° elb.)	CPVC	IPEX (System 636)	199	197201
4" Two (and single) pipes roof or wall terminal (90° elb.)	CPVC	IPEX (System 636)	399, 500	197202
3" Wall termination kit	PVC	IPEX (System 636)	199	081219
3" Low profile wall termination kit	PVC	IPEX (System 636)	199	196985
4" Low profile wall termination kit	PVC	IPEX (System 636)	399, 500	196986
6" Two (and single) pipes roof or wall terminal (90° elb.)	CPVC	IPEX (System 636)	750, 1000	197203
3" Bird screen	PVC/CPVC	IPEX (System 636)	199	196051
4" Bird screen	PVC/CPVC	IPEX (System 636)	399, 500	196052
6" Bird screen	PVC/CPVC	IPEX (System 636)	750, 1000	196090
3" (80mm) Two (and single) pipes roof or wall terminal (90° elb.)	Polypropylene	Centrotherm (Innoflue System)	199	ISELL0387UV
4" (110mm) Two (and single) pipes roof or wall terminal (90° elb.)	Polypropylene	Centrotherm (Innoflue System)	399, 500	ISELL0487UV
6" (160mm) Two (and single) pipes roof or wall terminal (90° elb.)	Polypropylene	Centrotherm (Innoflue System)	750, 1000	ISELL0687UV
3" (80mm) Heater adapter	Polypropylene	Cosmogas	199	62617361
4" (110 mm) Heater adapter	Polypropylene	Cosmogas	399, 500	62617359
6" (160mm) Heater adapter	Polypropylene	Cosmogas	750, 1000	62617357
3" (80mm) Bird screen	Polypropylene	Centrotherm (Innoflue System)	199	IASPP03
4" (110mm) Bird screen	Polypropylene	Centrotherm (Innoflue System)	399, 500	IASPP04
6" (160mm) Bird screen	Polypropylene	Centrotherm (Innoflue System)	750, 1000	IASSS06
3" (80mm) Two (and single) pipes roof or wall terminal (90°elbow)	Polypropylene	Z-Flex U.S. Inc.	199	2ZDE387UV
4" (110mm) Two (and single) pipes roof or wall terminal (90°elbow)	Polypropylene	Z-Flex U.S. Inc.	399, 500	2ZDE487UV
6" (160mm) Two (and single) pipes roof or wall terminal (90°elbow)	Polypropylene	Z-Flex U.S. Inc.	750, 1000	2ZDE687
3" (80mm) Heater adapter	Polypropylene	Z-Flex U.S. Inc.	199	2ZDCPVCG3
4" (110mm) Heater adapter	Polypropylene	Z-Flex U.S. Inc.	399, 500	2ZDCPVCG4
6" (160mm) Heater adapter	Polypropylene	Z-Flex U.S. Inc.	750, 1000	2ZDCPVCG6
3" (80mm) Bird screen	Polypropylene	Z-Flex U.S. Inc.	199	2ZDES3
4" (110mm) Bird screen	Polypropylene	Z-Flex U.S. Inc.	399, 500	2ZDES4
6" (160mm) Bird screen	Polypropylene	Z-Flex U.S. Inc.	750, 1000	2ZDES6
3" Two (and single) pipes roof or wall terminal (90° elb.)	Stainless steel	Duravent (FasNSeal)	199	FSELB9003
4" Two (and single) pipes roof or wall terminal (90° elb.)	Stainless steel	Duravent (FasNSeal)	399, 500	FSELB9004
6" Two (and single) pipes roof or wall terminal (90° elb.)	Stainless steel	Duravent (FasNSeal)	750, 1000	FSELB9006
3" Heater adapter	Stainless steel	Duravent (FasNSeal)	199	FSA-3PVCS-3FNSF
4" Heater adapter	Stainless steel	Duravent (FasNSeal)	399, 500	FSA-4PVCS-4FNSF
6" Heater adapter	Stainless steel	Duravent (FasNSeal)	750, 1000	FSA-6PVCS-6FNSF

12 - INSTALLATION - CATEGORY IV: Vent and combustion air

3" Bird screen	Stainless steel	Duravent (FasNSeal)	199	FSBS3
4" Bird screen	Stainless steel	Duravent (FasNSeal)	399, 500	FSBS4
6" Bird screen	Stainless steel	Duravent (FasNSeal)	750, 1000	FSBS6
3" (80mm) Two (and single) pipes roof or wall terminal (90°elbow)	Stainless steel	Z-Flex U.S. Inc.	199	2SVSTEX0390
4" (110mm) Two (and single) pipes roof or wall terminal (90°elbow)	Stainless steel	Z-Flex U.S. Inc.	399, 500	2SVSTEX0490
6" (160mm) Two (and single) pipes roof or wall terminal (90°elbow)	Stainless steel	Z-Flex U.S. Inc.	750, 1000	2SVVE0690
3" (80mm) Heater adapter	Stainless steel	Z-Flex U.S. Inc.	199	2VSPVC03
4" (110mm) Heater adapter	Stainless steel	Z-Flex U.S. Inc.	399, 500	2VSPVC04
6" (160mm) Heater adapter	Stainless steel	Z-Flex U.S. Inc.	750, 1000	2VSPVC06
3" (80mm) Bird screen	Stainless steel	Z-Flex U.S. Inc.	199	Included in elbow
4" (110mm) Bird screen	Stainless steel	Z-Flex U.S. Inc.	399, 500	Included in elbow
6" (160mm) Bird screen	Stainless steel	Z-Flex U.S. Inc.	750, 1000	2SVSTPX06

Figure 12-8 Approved vent manufacturers and items

12.5 - Air inlet pipe materials:

! WARNING!!! The air inlet pipe(s) must be sealed. Improper sealed can result in excessive levels of carbon monoxide which can result in severe personal injury or death!

Choose acceptable combustion air inlet pipe materials from the following list:

- PVC, CPVC
- AL29-4C, stainless steel material to be sealed to specification of its manufacturer.
- Polypropylene material to be sealed to specification of its manufacturer.

! WARNING!!! Using air intake materials other than those specified, mixing the specified materials, failure to properly seal all seams and joints or failure to follow the manufacturer's instructions can result in flue gas recirculation, spillage of flue products and carbon monoxide emissions causing severe personal injury or death.

NOTICE! Polypropylene and stainless steel pipe may require an adapter (not provided) to transition between the air inlet connection on the appliance and the air inlet pipe.

NOTICE! The use of insulated material for the combustion air inlet pipe is recommended in cold climates to prevent the condensation of airborne moisture in the incoming combustion air.

NOTICE! Combustion air piping must be supported per guidelines listed in the "National Mechanical code", section 305, table 305.4 or local codes dictate.

12.5.1 - Sealing of PVC or CPVC air inlet pipe

The PVC or CPVC air inlet pipe should be cleaned and sealed with the pipe manufacturer's recommended solvents and standard commercial pipe cement for the material used. The PVC or CPVC air inlet pipe should use a silicone sealant MOMENTIVE - RTV 106, to ensure a proper seal at the appliance connection and the air inlet cap connection. Proper sealing of the air inlet pipe ensures that combustion air will be free of contaminants and supplied in proper volume. When a sidewall or vertical rooftop combustion air supply system is

disconnected for any reason, the air inlet pipe must be resealed to ensure that combustion air will be free of contaminants and supplied in proper volume.

! WARNING!!! Failure to properly seal all joints and seams as required in the air inlet piping may result in flue gas recirculation, spillage of flue products and carbon monoxide emissions causing severe personal injury or death.

! WARNING!!! All air intake pipes must be glued, properly supported and pitched a minimum of a 1/4 inch per foot out to the heater (to allow drainage of water into the appliance). Failure to follow this warning could result in excessive levels of carbon monoxide or a fire, which can result in severe personal injury or death!

12 - INSTALLATION - CATEGORY IV: Vent and combustion air

12.6 - PVC/CPVC vent piping materials

! WARNING!!! Use only the materials listed in Figures 12-7 and 12-8 for vent pipe, and fittings. **DO NOT** mix systems of different types or manufacturers, unless listed in this manual. Failure to comply could result in severe personal injury, death, or substantial property damage.

! WARNING!!! This appliance requires a special venting system. The vent pipe must be connected to the heater following Section 12.6.1. Use only the vent materials, primer, and cement specified in this manual to make the vent connections. Failure to follow this warning could result in fire, personal injury, or death.

! WARNING!!! Do not insulate PVC/CPVC exhaust pipe nor install into an enclosure, closet, alcove or any other obstruction thereby preventing the cooling of the exhaust pipe. Failure to follow this warning could result in excessive levels of carbon monoxide or a fire, which can cause severe personal injury or death!

! WARNING!!! Improper installation of PVC or CPVC systems may result in excessive levels of carbon monoxide or a fire, which can cause severe personal injury or death!

! WARNING!!! All vent pipes must be glued, properly supported, and the exhaust must be pitched a minimum of a 1/4 inch per foot back to the heater (to allow drainage of condensate). Failure to follow this warning could result in excessive levels of carbon monoxide or a fire, which can result in severe personal injury or death!

NOTICE! Installation must comply with local requirements and with the National Fuel Gas Code, ANSI Z223.1 for U.S. installations or CSA B149.1 for Canadian installations. For installation in Canada, vent pipe system must be certified to ULC-S636 (see Figures 12-7).

NOTICE! Installation of a PVC/CPVC vent system should adhere to the PVC/CPVC vent manufacturer's installation instructions supplied with the vent system.

12.6.1 - Installing PVC/CPVC vent and air piping

NOTICE! Use only cleaners, primers, and solvents that are approved for the materials which are joined together.

1. Work from the heater to vent or air termination. Do not exceed the lengths given in Section 12.3.
2. Cut pipe to the required lengths and deburr the inside and outside of the pipe ends.
3. Bevel outside of each pipe end to ensure even cement distribution when joining.
4. Clean all pipe ends and fittings using a clean dry rag (Moisture will retard curing and dirt or grease will prevent adhesion).

Connection of the the vent or air piping to the heater adapters

5. Dry fit vent or air piping to ensure proper fit up before assembling pipes to the heater adapters. The pipe should go completely into the adapter to ensure proper sealing after sealant is applied.
 - a. Handle adapters and pipes carefully to prevent contamination of surfaces.

- b. Apply a liberal even coat of MOMENTIVE - RTV 106 high temperature silicone (or equivalent) to the the pipe end approximately 1/2" beyond the socket depth.
- c. While the MOMENTIVE - RTV 106 high temperature silicone is still wet, insert the pipe into the heater adapter. **NOTICE!** If voids are present, sufficient MOMENTIVE - RTV 106 was not applied and joint could be defective.
- d. Tight the clamp to mechanically secure the joint

Connection between pipes and /or elbows and/or terminals of the the vent or air piping

6. Dry fit vent or air piping to ensure proper fit up before assembling any joint. The pipe should go a third to two-thirds into the fitting to ensure proper sealing after cement is applied.
7. Priming and Cementing:
 - a. Handle fittings and pipes carefully to prevent contamination of surfaces.
 - b. Apply a liberal even coat of primer to the fitting socket.
 - c. Apply a liberal even coat of primer to the pipe end to approximately 1/2" beyond the socket depth.
 - d. Apply a second primer coat to the fitting socket.
 - e. While primer is still wet, apply an even coat of approved cement to the pipe equal to the depth of the fitting socket.
 - f. While primer is still wet, apply an even coat of approved cement to the fitting socket.
 - g. Apply a second coat of cement to the pipe.
 - h. While the cement is still wet, insert the pipe into the fitting, if possible twist the pipe a 1/4 turn as you insert it. **NOTICE!** If voids are present, sufficient cement was not applied and joint could be defective.
 - i. Wipe excess cement from the joint removing ring or beads as it will needlessly soften the pipe.

12 - INSTALLATION - CATEGORY IV: Vent and combustion air

CAUTION!!! Apply a liberal even coat of **MOMENTIVE - RTV 106** high temperature silicone (or equivalent) to the internal side of the heater adapter (item "B" and "P" fig.12-9)

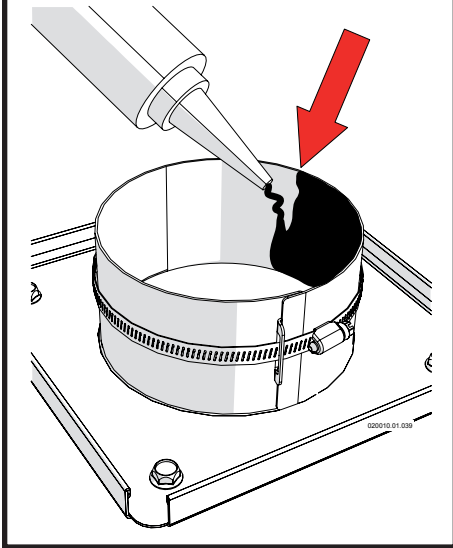

12.6.2 - PVC/CPVC air intake connection

Combustion Air Intake connection (see Figure 12-9 Item "P"). This connection is used to provide combustion air directly to the heater from outdoors. Combustion air piping must be supported per guidelines listed in the National Mechanical Code, Section 305, Table 305.4 or as local codes dictate. To connect a PVC/CPVC pipe to the air intake connection proceed as follow while referring to Figure 12-9:

1. Prepare the connection between adapter "P" and pipe "N" like described on Section 12.6.1;
2. Insert the air inlet PVC/CPVC pipe, for 3" into the adapter "P";
3. Tighten the clamp "F" to mechanically secure the adapter "P" to the pipe.

12.6.3 - PVC/CPVC vent connection

Vent connection (see Figure 12-9 Item "C"). This connection is used to provide a passageway for conveying combustion gas to the

outside. Vent piping must be supported per the National Building Code, Section 305, Table 305.4 or as local codes dictate.

To connect a PVC/CPVC pipe to the vent connection proceed as follow while referring to Figure 12-9:

1. Prepare the connection between adapter "B" and pipe "G" like described on Section 12.6.1;
2. Insert the flue exhaust PVC/CPVC pipe, for 3" into the adapter "B";
3. Tighten the clamp "F" to mechanically secure the adapter "B" to the pipe.

WARNING!!! Do not insulate PVC/CPVC exhaust pipe nor install into an enclosure, closet, alcove or any other obstruction thereby preventing the cooling of the exhaust pipe. Failure to follow this warning could result in excessive levels of carbon monoxide or a fire, which can result in severe personal injury or death!

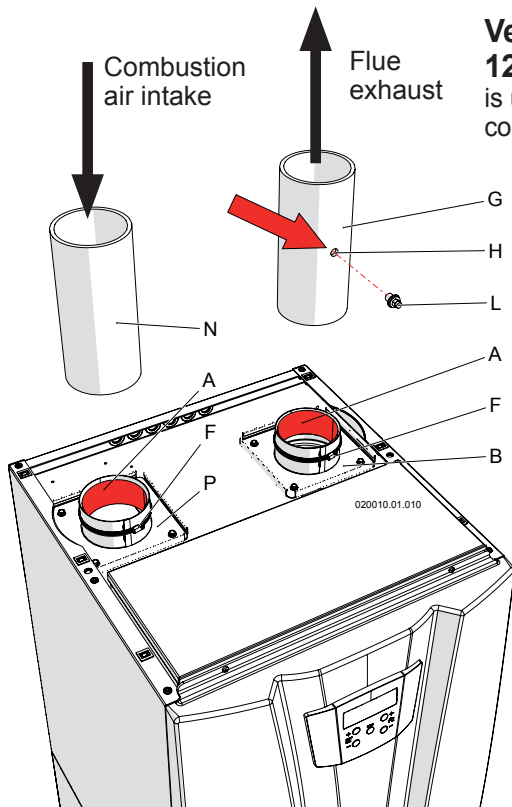

- A = MOMENTIVE - RTV 106 high temperature silicone (or equivalent) (Field provided)
- B = Flue exhaust adapter for PVC/CPVC pipe
- F = mechanically secure clamp
- G = PVC/CPVC exhaust pipe (Field provided)
- H = Combustion analization probe (Field installed)
- L = cap (Field provided)
- N = PVC/CPVC air inlet pipe (Field provided)
- P = Air intake adapter for PVC/CPVC pipe

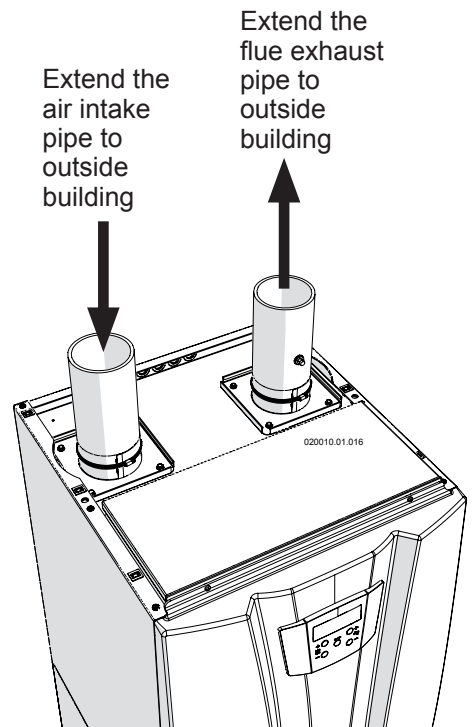

Figure 12-9 PVC/CPVC air intake/vent connection

Figure 12-10 PVC/CPVC air intake/Vent connection correctly in place

12 - INSTALLATION - CATEGORY IV: Vent and combustion air

12.7 - Stainless steel vent piping materials

! WARNING!!! Use only the materials, vent systems, and terminations listed in Figures 12-7 and 12-8. **DO NOT** mix vent systems of different types or manufacturers, unless listed in this manual. Failure to comply could result in severe personal injury, death, or substantial property damage.

! WARNING!!! This appliance requires a special venting system. The field provided vent heater adapter (Figure 12-11, item “B”) must be connected to the heater following Section 12.7.2. Failure to follow this warning could result in fire, personal injury, or death.

! WARNING!!! Improper installation of Stainless steel systems may result in injury or death.

! WARNING!!! Use only water-based lubricants on joints. Never use hydrocarbons-based lubricants because they would destroy gaskets. Failure to follow this warning could result in excessive levels of carbon monoxide, which can result in severe personal injury or death!

NOTICE! Installation must comply with local requirements and with the National Fuel Gas Code, ANSI Z223.1 for U.S. installations or CSA B149.1 for Canadian installations.

NOTICE! For installation in Canada, vent pipe system must be certified to ULC-S636 (see Figure 12-7).

NOTICE! All vent pipes connections must be secured following manufacturer instruction, properly supported, and the exhaust must be pitched a minimum of a 1/4 inch per foot back to the heater (to allow drainage of condensate).

NOTICE! Installation of a stainless steel vent system should adhere to the stainless steel vent manufacturer’s installation instructions supplied with the vent system.

NOTICE! The installer must use a specific vent starter adapter at the flue collar connection, supplied by the vent manufacturer to adapt to its vent system. See Figure 12-8 for approved vent adapters.

12.7.1 - Stainless steel air intake connection

Combustion Air Intake connection (see Figure 12-11 Item “M”).

This connection is used to provide combustion air directly to the heater from outdoors. Combustion air piping must be supported per guidelines listed in the National Mechanical Code, Section 305, Table 305.4 or as local codes dictate.

To connect a stainless steel pipe to the air intake connection proceed as follows while referring to Figure 12-11:

1. Dry fit adapter “R” and heater connection “P” to ensure proper fit up before assembling the adapter to the heater. The adapter “R” should go completely into the heater connection to ensure proper sealing after sealant is applied.
 - a. Handle adapters “R” and heater adapter “P” carefully to prevent contamination of surfaces.
 - b. Apply a liberal even coat of MOMENTIVE - RTV 106 high temperature silicone (or equivalent) to the adapter “R” approximately 2” beyond the socket depth.
 - c. While the MOMENTIVE - RTV 106 high temperature silicone is still wet, insert the adapter “R” into the heaterconnection “P”.

NOTICE! If voids are present, sufficient MOMENTIVE - RTV 106 was not applied and joint could be defective.
 - d. Tight the clamp to mechanically secure the joint
2. Insert air intake pipe “N”, into adapter “R”, following instruction of stainless steel pipe manufacturer.

12 - INSTALLATION - CATEGORY IV: Vent and combustion air

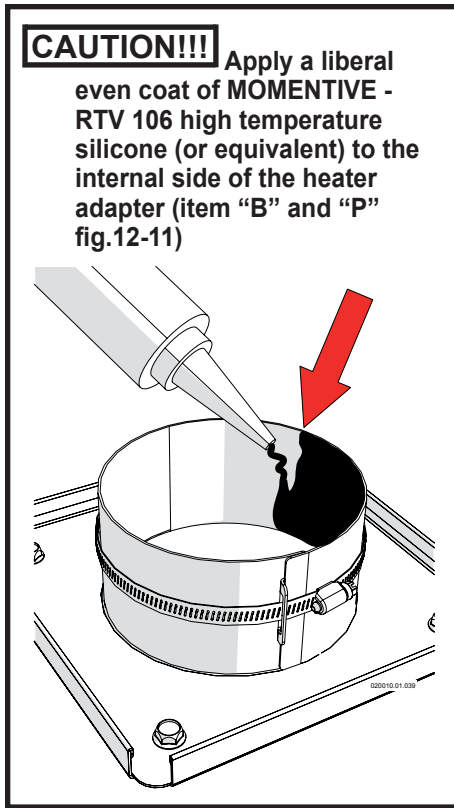

12.7.2 - Stainless steel vent connection

Vent connection (Figure 12-11 item "C") is used to provide a passageway for conveying combustion gases to the outside. Vent piping must be supported per the National Building Code, Section 305, Table 305.4 or as local codes dictate.

To connect a stainless steel pipe to the vent connection proceed as follows while referring to Figure 12-11:

1. Dry fit adapter "R" to ensure proper fit up before assembling adapter to the heater connection "B". The adapter "R" should go completely into the heater adapter to ensure proper sealing after sealant is applied.
 - a. Handle adapters "R" and heater connection "B" carefully to prevent contamination of surfaces.

- b. Apply a liberal even coat of **MOMENTIVE - RTV 106** high temperature silicone (or equivalent) to the adapter "R" approximately 2" beyond the socket depth.
 - c. While the **MOMENTIVE - RTV 106** high temperature silicone is still wet, insert the adapter "R" into the heater connection "B". **NOTICE!** If voids are present, sufficient **MOMENTIVE - RTV 106** was not applied and joint could be defective.
 - d. Tight the clamp to mechanically secure the joint
2. Insert vent pipe "G", into adapter "R", following instruction of stainless steel pipe manufacturer.

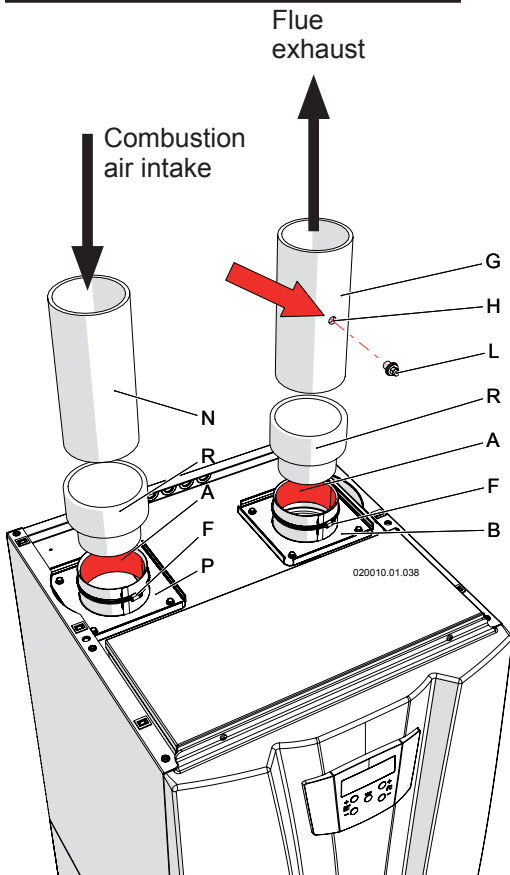

- A = **MOMENTIVE - RTV 106** high temperature silicone (or equivalent) (Field provided)
- B = Flue exhaust connection
- F = Mechanically secure clamp
- G = Stainless steel exhaust pipe (Field provided)
- H = Combustion analization probe (Field installed)
- L = Cap (Field provided)
- N = Stainless steel air inlet pipe (Field provided)
- P = Air intake connection
- R = Stainless steel adapter (Field provided)

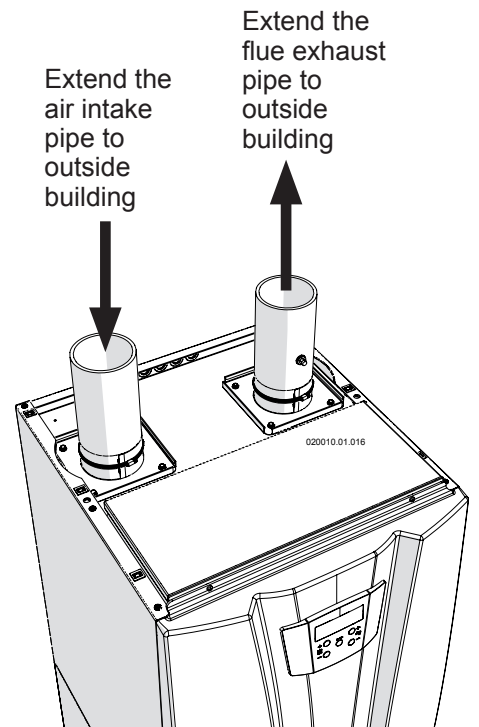

Figure 12-11 Stainless steel air intake/vent connection

Figure 12-12 Stainless steel air intake/vent connection correctly in place

12.8 - Polypropylene vent piping materials

! WARNING!!! Use only the materials listed in Figures 12-7 and 12-8 for vent pipe, and fittings. **DO NOT** mix vent systems of different types or manufacturers, unless listed in this manual. Failure to comply could result in severe personal injury, death, or substantial property damage.

! WARNING!!! This appliance requires a special venting system. The field provided vent fittings must be connected to the heater following Section 12.8.2. Failure to follow this warning could result in fire, personal injury, or death.

! WARNING!!! Do not insulate polypropylene exhaust pipe nor install into an enclosure, closet, alcove or any other obstruction thereby preventing the cooling of the exhaust pipe. Failure to follow this warning could result in excessive levels of carbon monoxide or a fire, which can result in severe personal injury or death!

! WARNING!!! Improper installation of Polypropylene systems may result in injury or death.

! WARNING!!! Use only water-based lubricants on joints. Never use hydrocarbons-based lubricants because they would destroy gaskets. Failure to follow this warning could result in excessive levels of carbon monoxide, which can result in severe personal injury or death!

NOTICE! Installation must comply with local requirements and with the National Fuel Gas Code, ANSI Z223.1 for U.S. installations or CSA B149.1 for Canadian installations.

For installation in Canada, vent pipe system must be certified to ULC-S636 (see Figure 12-7).

NOTICE! All vent pipes connections must be secured following manufacturer instruction, properly supported, and the exhaust must be pitched a minimum of a 1/4 inch per foot back to the heater (to allow drainage of condensate).

NOTICE! Installation of a Polypropylene vent system should adhere to the polypropylene vent manufacturer's installation instructions supplied with the vent system.

12 - INSTALLATION - CATEGORY IV: Vent and combustion air

CAUTION!!! Apply a liberal even coat of **MOMENTIVE - RTV 106 high temperature silicone (or equivalent)** to the internal side of the heater adapter (item "B" and "P" fig.12-13)

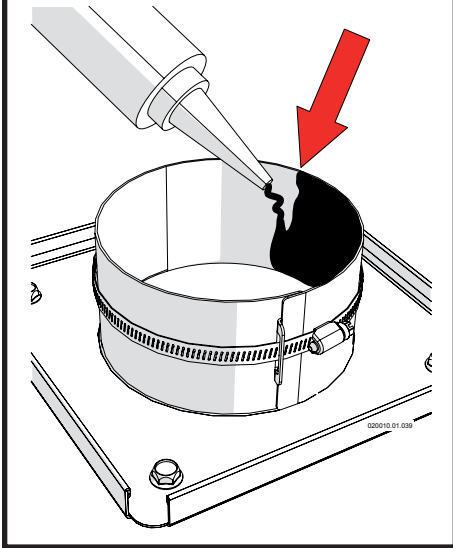

12.8.1 - Polypropylene air intake connection

Combustion Air Intake connection (see Figure 12-13 Item "M") is used to provide combustion air directly to the heater from outdoors. Combustion air piping must be supported per guidelines listed in the National Mechanical Code, Section 305, Table 305.4 or as local codes dictate.

To connect a polypropylene pipe to the air intake connection proceed as follows while referring to Figure 12-13:

1. install heater adapter "P" (Field provided) above exit "M" using gasket "D" and bolts "E".
2. Insert vent pipe "N", into adapter "P", following instruction of polypropylene pipe manufacturer.

12.8.2 - Polypropylene vent connection

Vent connection (Figure 12-13 item "C") is used to provide a passageway for conveying combustion gases to the outside. Vent piping must be supported per the National Building Code, Section 305, Table 305.4 or as local codes dictate.

To connect a polypropylene pipe to the vent connection proceed as follows while referring to Figure 12-13:

1. install heater adapter "B" (Field provided) above exit "C" using gasket "D" and bolts "E".
2. Insert vent pipe "G", into adapter "B", following instruction of polypropylene pipe manufacturer.

WARNING!!! Do not insulate polypropylene exhaust pipe nor install into an enclosure, closet, alcove or any other obstruction thereby preventing the cooling of the exhaust pipe. Failure to follow this warning could result in excessive levels of carbon monoxide or a fire, which can result in severe personal injury or death!

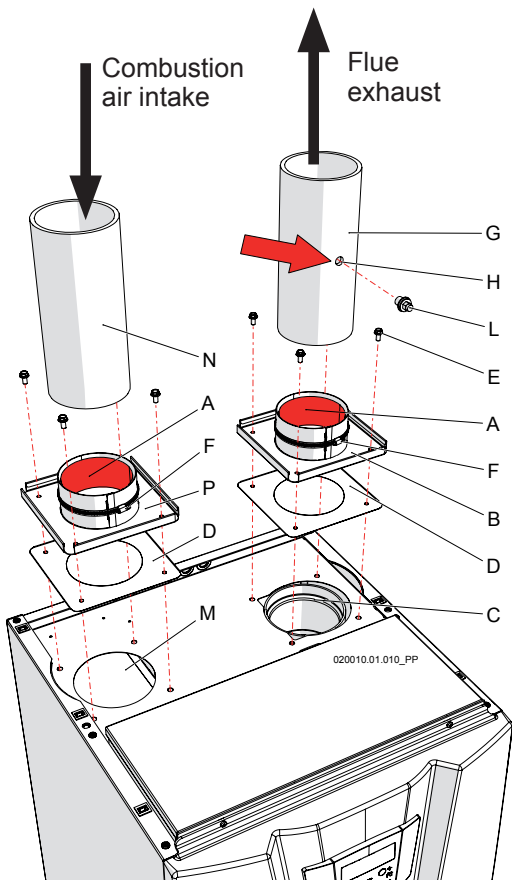

- A = MOMENTIVE - RTV 106 high temperature silicone (or equivalent) (Field provided)
- B = Flue exhaust adapter for PVC/CPVC pipe
- C = Flue exhaust connection
- D = Gasket
- E = Fixing screws
- F = Mechanically secure clamp
- G = PVC/CPVC exhaust pipe (Field provided)
- H = Combustion analysis probe (Field installed)
- L = Cap (Field provided)
- N = PVC/CPVC air inlet pipe (Field provided)
- P = Air intake adapter for PVC/CPVC pipe

Figure 12-13 Polypropylene air intake/vent connection

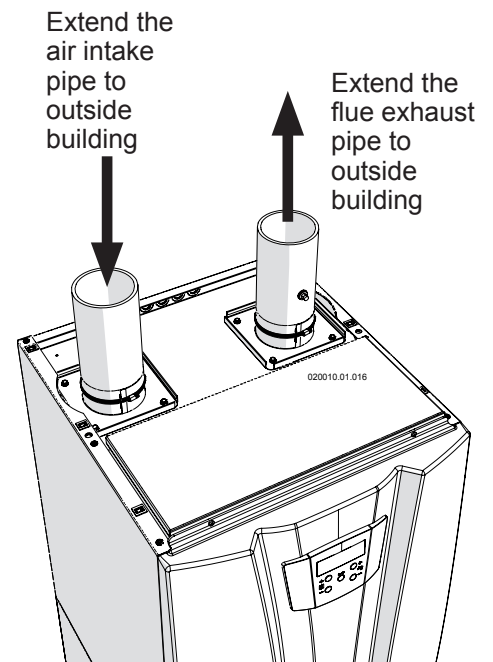

Figure 12-14 Polypropylene air intake/vent connection correctly in place

12 - INSTALLATION - CATEGORY IV: Vent and combustion air

12.9 - Single pipe vent (not sealed combustion)

For heaters for connection to gas vents or chimneys, vent installations shall be in accordance with "Venting of Equipment," of the National Fuel Gas Code, ANSI Z223.1/NFPA 54, or "Venting Systems and Air Supply for Appliances," of the Natural Gas and Propane Installation Code, CAN/CSA B149.1, or applicable provisions of the local building codes.

! WARNING!!! When utilizing the single pipe vent method, provisions for combustion and ventilation air must be in accordance with Air for Combustion and Ventilation, of the latest edition of the National Fuel Gas Code, ANSI Z223.1, in Canada, the latest edition of CGA Standard B149 Installation Code for Gas Burning Appliances and Equipment, or applicable provisions of the local building codes (see section 5.1).

Failure to follow this warning could result in excessive levels of carbon monoxide, which can cause severe personal injury or death!

Commercial applications utilizing this heater may be installed with a single pipe carrying the flue products to the outside while using combustion air from the equipment room. In this case the following conditions and considerations must be followed.

NOTICE! There will be a noticeable increase in the noise level during normal operation from the inlet air opening.

NOTICE! Vent system and terminations must comply with the venting instructions set forth in Sections 12.6, 12.7 and 12.8.

! WARNING!!! Use only the materials, vent systems, and terminations listed in Figures 12-7 and 12-8. DO NOT mix vent systems of different types or manufacturers, unless listed in this manual. Failure to comply could result in severe personal injury, death, or substantial property damage.

! WARNING!!! Fire danger due to flammable materials or liquids. Do not store flammable materials and liquids in the immediate vicinity of the heater.

! WARNING!!! Heater must be clear and free from combustible materials, gasoline and other flammable vapors and liquids, and corrosive liquids and vapors. Never use chlorine and hydrocarbon containing chemicals (such as spray chemicals, solution and cleaning agents, paints, glues etc.) in the vicinity of the heater. Do not store and use these chemicals in the heater room. Avoid excessive dust formation and build-up. Failure to comply could result in fire, severe personal injury, death, or substantial property damage.

! WARNING!!! Where exhaust fans, clothes dryers, and kitchen ventilation systems interfere with the operation of appliances, makeup air shall be provided. Failure to follow this warning could result in excessive levels of carbon monoxide, which can cause severe personal injury or death!

NOTICE! For installation in Canada, vent pipe system must be certified to ULC-S636 (see Table 12-7).

NOTICE! All vent pipes connections must be secured following manufacturer instruction, properly supported, and the exhaust must be pitched a minimum of a 1/4 inch per foot back to the heater (to allow drainage of condensate).

NOTICE! Vent pipe system shall be installed in a way to prevent accumulation of condensate.

12 - INSTALLATION - CATEGORY IV: Vent and combustion air

12.9.1 - Determine location

Locate the vent termination using the following guidelines:

1. The total length of piping for vent must not exceed the limits given in the Section 12.3.
2. You must consider the surroundings when terminating the vent:
 - a. Position the vent termination where vapors will not damage nearby shrubs, plants or air conditioning equipment or be objectionable.
 - b. The flue products will form a noticeable plume as they condense in cold air. Avoid areas where the plume could obstruct window views.
 - c. Prevailing winds could cause freezing of condensate and water/ice buildup where flue products impinge on building surfaces or plants.
 - d. Avoid possibility of accidental contact of flue products with people or animals.
 - e. Do not locate the terminations where wind eddies could affect performance or cause recirculation, such as inside building corners, near adjacent buildings or surfaces, window wells, stairwells, alcoves, courtyards, or other recessed areas.
 - f. Do not terminate above any door or window. Condensate can freeze, causing ice formations.
 - g. Locate or guard vent to prevent condensate damage to exterior finishes.
3. The vent piping must terminate in an elbow pointed outward as shown in Figures 12-15 or 12-16 or in a roof as shown in Figure 12-22.



WARNING!!!

Do not exceed the maximum lengths of the outside vent piping shown in Figures 12-15, 12-16 or 12-22. Excessive length exposed to the outside could cause freezing of condensate in the vent pipe, resulting in potential heater shutdown.

4. Maintain clearances as expected by "Venting of Equipment," of the National Fuel Gas Code, ANSI Z223.1/NFPA 54, or "Venting Systems

and Air Supply for Appliances" of the Natural Gas and Propane Installation Code, CAN/CSA B149.1, or applicable provisions of the local building codes.

Also maintain the following:

- a. Vent must terminate:
 - At least 6 feet from adjacent walls.
 - No closer than 12 inches below roof overhang.
 - At least 7 feet above any public walkway.
 - At least 3 feet above any forced air intake within 10 feet.
 - No closer than 4 feet below or horizontally from any door or window or any other gravity air inlet.
- b. Do not terminate closer than 4 feet horizontally from any electric meter, gas meter, regulator, relief valve, or other equipment. Never terminate above or below any of these within 4 feet horizontally. **Item unique to CANADA: vent system shall terminate at least 6 ft from electrical and gas meters.**
5. Locate termination so it is not likely to be damaged by foreign objects, such as stones or balls, or subject to buildup of leaves or sediment.

12 - INSTALLATION - CATEGORY IV: Vent and combustion air

12.10 - Sidewall termination - Two pipes

12.10.1 - Vent/air termination

! WARNING!!! A gas vent extending through an exterior wall shall not terminate adjacent to a wall or below building extensions such as eaves, parapets, balconies, or decks. Failure to comply could result in severe personal injury, death, or substantial property damage.

! WARNING!!! Do not connect any other appliance to the vent pipe or multiple heaters to a common vent pipe. Failure to comply could result in severe personal injury, death, or substantial property damage.

NOTICE! Installation must comply with local requirements and with the National Fuel Gas Code, ANSI Z223.1 for U.S. installations or CSA B149.1 for Canadian installations.

12.10.2 - Determine location

Locate the vent/air terminations using the following guidelines:

1. The total length of piping for vent or air must not exceed the limits given in the Section 12.3.
2. You must consider the surroundings when terminating the vent and air:
 - a. Position the vent termination where vapors will not damage nearby shrubs, plants or air conditioning equipment or be objectionable.
 - b. The flue products will form a noticeable plume as they condense in cold air. Avoid areas where the plume could obstruct window views.
 - c. Prevailing winds could cause freezing of condensate and water/ice buildup where flue products impinge on building surfaces or plants.
 - d. Avoid possibility of accidental contact of flue products with people or animals.
 - e. Do not locate the terminations where wind eddies could affect performance or cause recirculation, such as inside building corners, near adjacent buildings or surfaces, window wells, stairwells, alcoves, courtyards, or other recessed areas.
 - f. Do not terminate above any door or window. Condensate can freeze, causing ice formations.
 - g. Locate or guard vent to prevent condensate damage to exterior finishes.
3. The air piping must terminate in a down-turned elbow as shown in Figures 12-15 and 12-16. This arrangement avoids recirculation of flue products into the combustion air stream.
4. The vent piping must terminate in an elbow pointed outward or away from the air inlet, as shown in Figures 12-15 and 12-16.

12 - INSTALLATION - CATEGORY IV: Vent and combustion air



WARNING!!!

Do not exceed the maximum lengths of the outside vent piping shown in Figures 12-15 and 12-16. Excessive length exposed to the outside could cause freezing of condensate in the vent pipe, resulting in potential heater shutdown.

5. Maintain clearances as shown in Figures 12-15 and 12-16. Also maintain the following:
 - a. Vent must terminate:
 - At least 6 feet from adjacent walls.
 - No closer than 12 inches below roof overhang.
 - At least 7 feet above any public walkway.
 - At least 3 feet above any forced air intake within 10 feet.
 - No closer than 12 inches below or horizontally from any door or window or any other gravity air inlet.
 - b. Air inlet must terminate at least 12 inches above grade or snow line; at least 12 inches below the vent termination;
 - c. Do not terminate closer than 6 feet horizontally from any electric meter, gas meter, regulator, relief valve, or other equipment. Never terminate above or below any of these within 6 feet horizontally.
6. Locate terminations so they are not likely to be damaged by foreign objects, such as stones or balls, or subject to buildup of leaves or sediment.

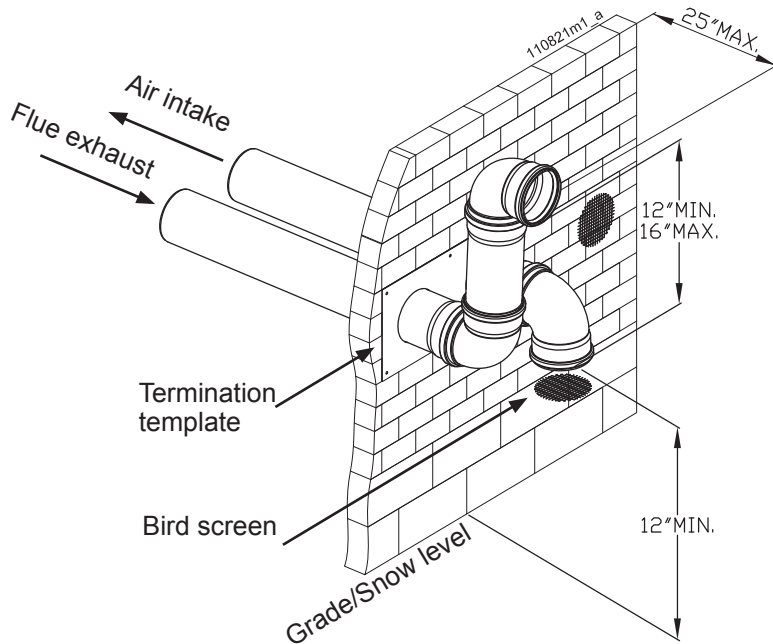

Figure 12-15 Two pipes sidewall termination of air and vent

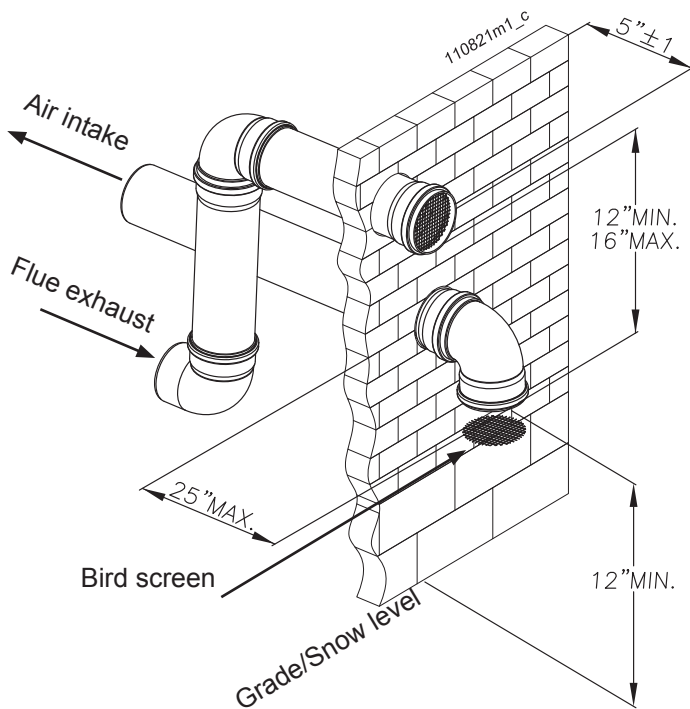

Figure 12-16 Two pipes sidewall termination of air and vent (if space permits)

12 - INSTALLATION - CATEGORY IV: Vent and combustion air

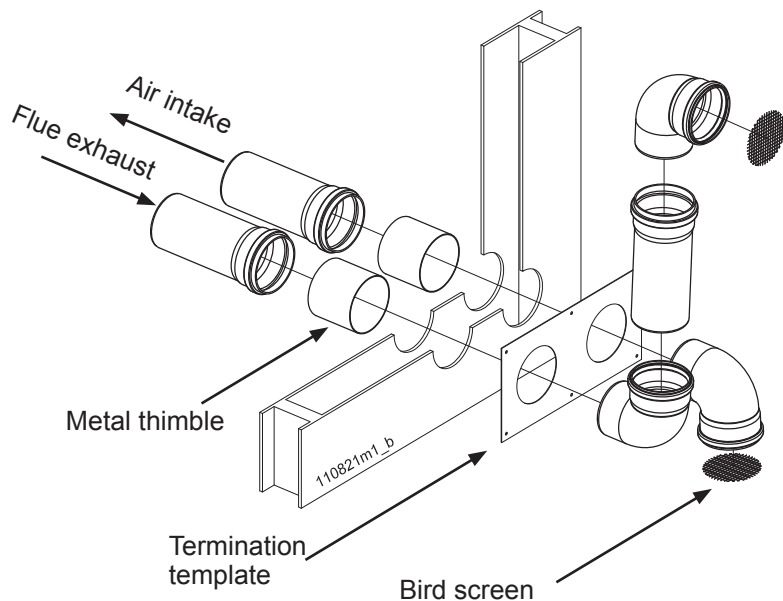
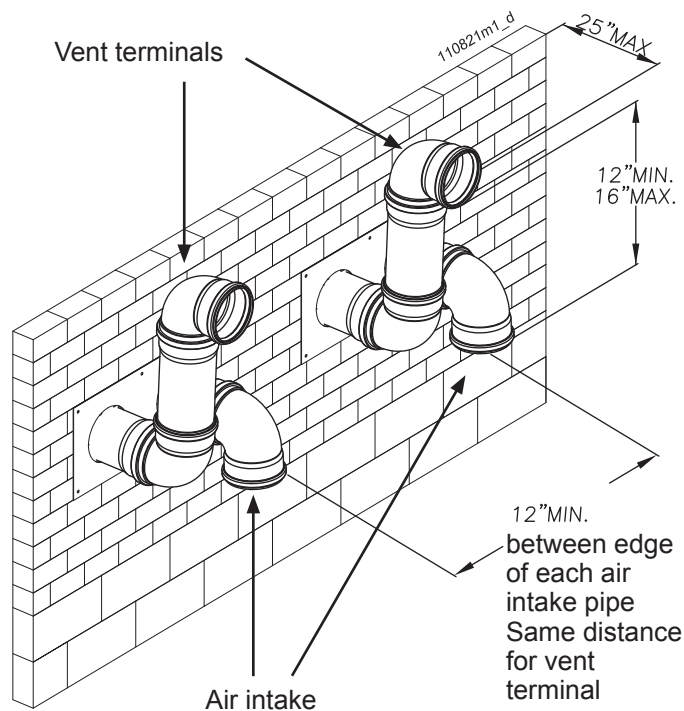

Figure 12-17 Two pipes sidewall termination assembly



NOTICE! Keep the air intake at min. 12" from grade or snow line. Provide vent and air intake with bird screen

Figure 12-18 Two pipes multiple heaters vent terminations

12.10.3 - Prepare wall penetrations

1. Air pipe penetration:
 - a. Cut a hole for the air pipe. Size the air pipe hole as close as desired to the air pipe outside diameter.
2. Vent pipe penetration:
 - a. Cut a hole for the vent pipe. For either combustible or noncombustible construction, size the vent pipe hole with at least a 1/2 inch clearance around the vent pipe outer diameter;
 - b. Insert a galvanized metal thimble in the vent pipe hole as shown in Figure 12-17.
3. Use a sidewall termination plate as a template for correct location of hole centers.
4. Follow all local codes for isolation of vent pipe when passing through floors or walls.
5. Seal exterior openings thoroughly with exterior caulk.

12.10.4 - Termination and fittings

1. The air termination coupling must be oriented at least 12 inches above grade or snow line as shown in Figures 12-15 and 12-16.
2. Maintain the required dimensions of the finished termination piping as shown in Figures 12-15 and 12-16.
3. Do not extend exposed vent pipe outside of the building more than what is shown in Figures 12-15 and 12-16. Condensate could freeze and block vent pipe.

12.10.5 - Multiple vent/air terminations

1. When terminating multiple heaters terminate each vent/air connection as shown in Figure 12-18.

! WARNING!!! All vent pipes and air inlets must terminate at the same height to avoid possibility of air inlet flue contamination that could result in excessive levels of carbon monoxide which can cause severe personal injury or death!

2. Place wall penetrations to obtain minimum clearance of 12 inches between edge of air inlet and adjacent vent outlet, as shown in Figure 12-18 for U.S. installations. For Canadian installations, provide clearances required by CSA B149.1 Installation Code.
3. The air inlet is part of a direct vent connection. It is not classified as a forced air intake with regard to spacing from adjacent heater vents.

12 - INSTALLATION - CATEGORY IV: Vent and combustion air

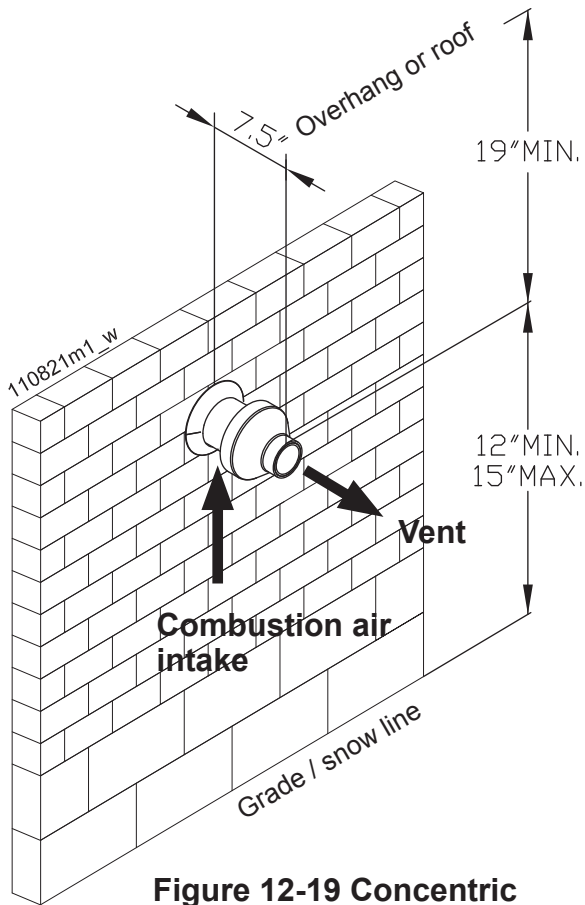

Figure 12-19 Concentric sidewall termination clearances

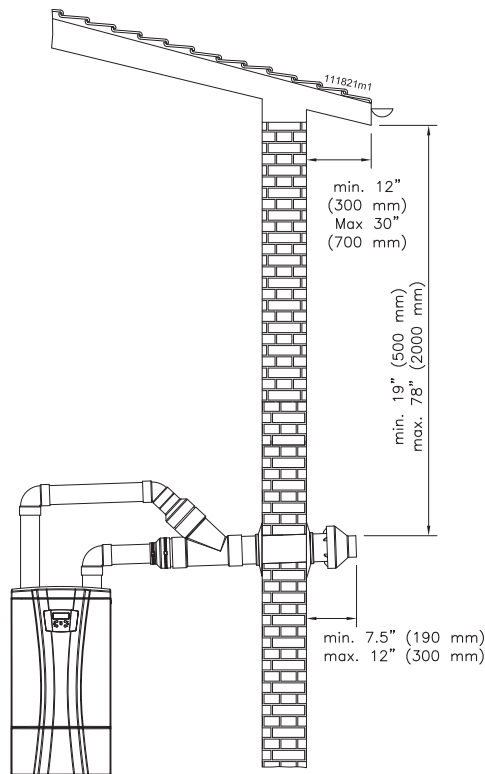

Figure 12-20 Concentric sidewall termination clearances

12.11 - Sidewall termination – Concentric vent

12.11.1 - Description and usage

The termination kit must terminate outside the structure and must be installed as shown in Figure 12-19.

The required concentric termination kit as well as combustion air and vent pipe materials are listed in Figures 12-7 and 12-8.

The termination ending must be protected from rain, see Figure 12-20.

12.11.2 - Sidewall termination installation

1. Determine the best location for the termination kit (see Figures 12-19 and 12-20).
2. The total length of piping for vent or air must not exceed the limits given in Section 12.3.
3. You must consider the surroundings when terminating the vent and air:
 - a. Position the vent termination where vapors will not damage nearby shrubs, plants or air conditioning equipment or be objectionable.
 - b. The flue products will form a noticeable plume as they condense in cold air. Avoid areas where the plume could obstruct window views.
 - c. Prevailing winds could cause freezing of condensate and water/ice buildup where flue products impinge on building surfaces or plants.
 - d. Avoid possibility of accidental contact of flue products with people or animals
 - e. Do not terminate above any door or window. Condensate can freeze, causing ice formations.
 - f. Locate or guard vent to prevent condensate damage to exterior finishes.
4. Cut one (1) hole 5 inch diameter into the structure to install the termination kit.
5. Install the Concentric vent kit following the concentric kit manufacturer's instruction.

NOTICE! Ensure termination location clearance dimensions are as shown in Figures 12-19 and 12-20.

CAUTION!!! DO NOT use field-supplied couplings to extend pipes. Airflow restriction will occur and may cause intermittent operation.

6. Operate the appliance one (1) heat cycle to ensure combustion air and vent pipes are properly connected to the concentric vent termination connections.

12 - INSTALLATION - CATEGORY IV: Vent and combustion air

12.11.3 - Multiventing sidewall terminations

When two or more direct vent appliances are vented near each other, each appliance must be individually vented and vent terminations may be installed as shown in Figure 12-21. It is important that vent terminations be made as shown to avoid recirculation of flue gas.



WARNING!!!

Do not connect any other appliance to the vent pipe or multiple heaters to a common vent pipe. Failure to comply could result in severe personal injury, death, or substantial property damage.

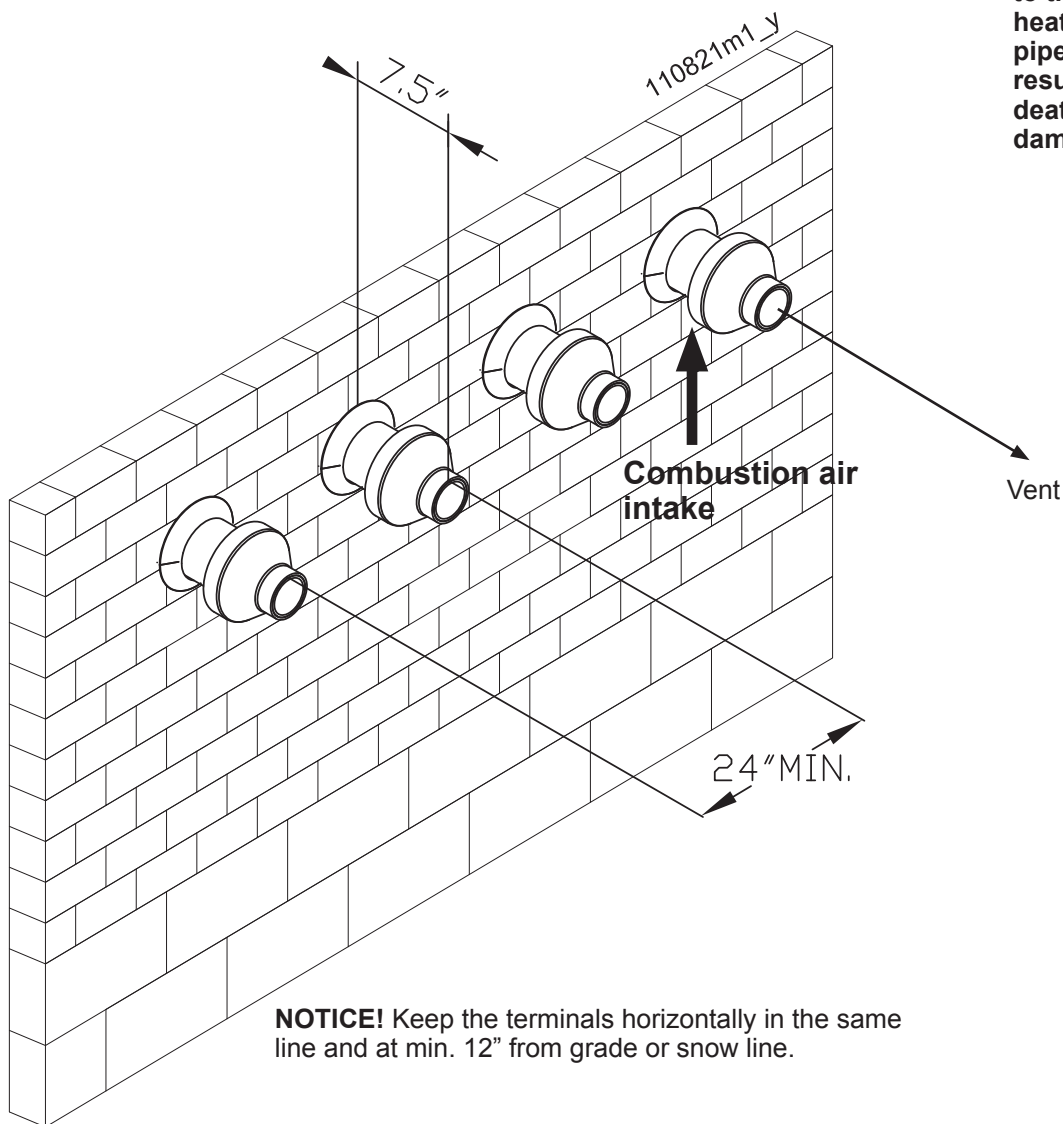

Figure 12-21 Concentric sidewall multiple heaters terminations

12 - INSTALLATION - CATEGORY IV: Vent and combustion air

12.12 - Vertical termination - Two pipes

! WARNING!!! Follow instructions below when determining vent location to avoid possibility of severe personal injury, death or substantial property damage.

! WARNING!!! Do not connect any other appliance to the vent pipe or multiple heaters to a common vent pipe. Failure to comply could result in severe personal injury, death, or substantial property damage.

Installation must comply with local requirements and with the National Fuel Gas Code, ANSI Z223.1 for U.S. installations or CSA B149.1 for Canadian installations.

12.12.1 - Determine location

Locate the vent/air terminations using the following guidelines:

1. The total length of piping for vent or air must not exceed the limits given in the Section 12.3.
2. The vent must terminate at least 3 feet above the highest place in which the vent penetrates the roof and at least 2 feet above any part of a building within 10 horizontal feet.
3. The air piping must terminate in a down-turned 180° return pipe no further than 2 feet from the center of the vent pipe. This placement avoids recirculation of flue products into the combustion air stream.
4. The vent piping must terminate at least 1 foot above the air intake. The air inlet pipe and vent pipe can be located in any desired position on the roof, but must always be no further than 2 feet apart and with the vent termination at least 1 foot above the air intake.
5. Locate terminations so they are not likely to be damaged by foreign objects, such as stones or balls, or subject to buildup of leaves or sediment.

12.12.2 - Prepare roof penetrations

1. Air pipe penetration: cut a hole for the air pipe. Size the air pipe hole as close as desired to the air pipe outside diameter.
2. Vent pipe penetration:
 - a. Cut a hole for the vent pipe. For either combustible or noncombustible construction, size the vent pipe hole with at least a 1/2 inch clearance around the vent pipe outer diameter;
 - b. Insert a galvanized metal thimble in the vent pipe hole.
3. Space the air and vent holes to provide the minimum spacing shown in Figure 12-22 and listed in Section 12.12.1.
4. Follow all local codes for isolation of vent pipe when passing through floors, ceilings, and roofs.
5. Provide flashing and sealing boots sized for the vent pipe and air pipe.

12.12.3 - Termination and fittings

1. Prepare the vent termination and the air termination elbow (Figure 12-22) by inserting bird screens.
2. The air piping must terminate in a down-turned 180° return bend as shown in Figure 12-22. Locate the air inlet pipe no further than 2 feet from the center of the vent pipe. This placement avoids recirculation of flue products into the combustion air stream.
3. Maintain the required dimensions of the finished termination piping as shown in Figure 12-22.
4. Do not extend exposed vent pipe outside of building more than shown in Figure 12-22. Condensate could freeze and block vent pipe.

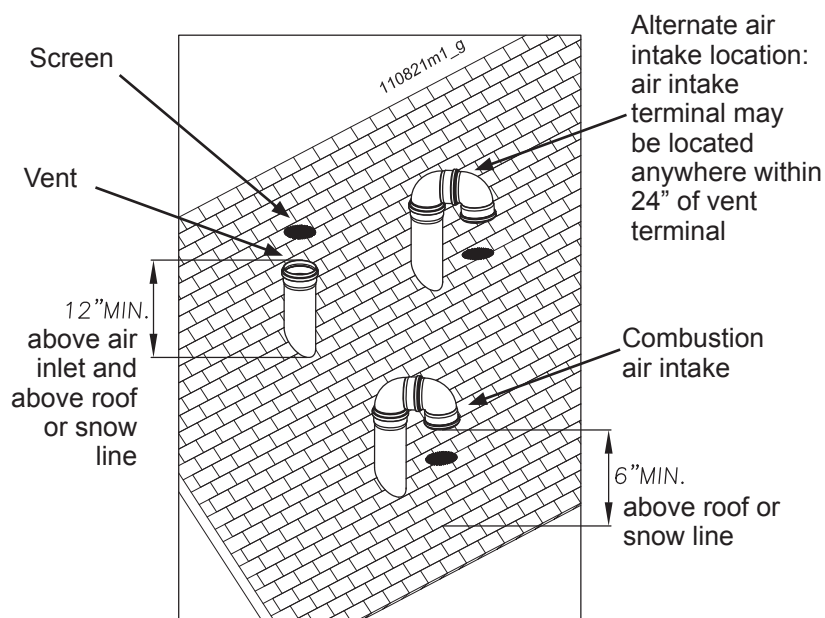

Figure 12-22 Two pipes vertical terminations of air and vent

12 - INSTALLATION - CATEGORY IV: Vent and combustion air

12.12.4 - Multiple vent/air terminations

1. When terminating multiple heaters, terminate each vent/air connection as shown in Figures 12-23 and 12-24.

⚠ WARNING!!! Terminate all vent pipes at the same height and all air pipes at the same height to avoid possibility of severe personal injury, death, or substantial property damage.

2. Place roof penetrations to obtain minimum clearance of 12 inches between edge of air intake elbow and adjacent vent pipe of another heater for U.S. installations (see Figure 12-23). For Canadian installations, provide clearances required by CSA B149.1 Installation Code.
3. The air inlet is part of a direct vent connection. It is not classified as a forced air intake with regard to spacing from adjacent heater vents.

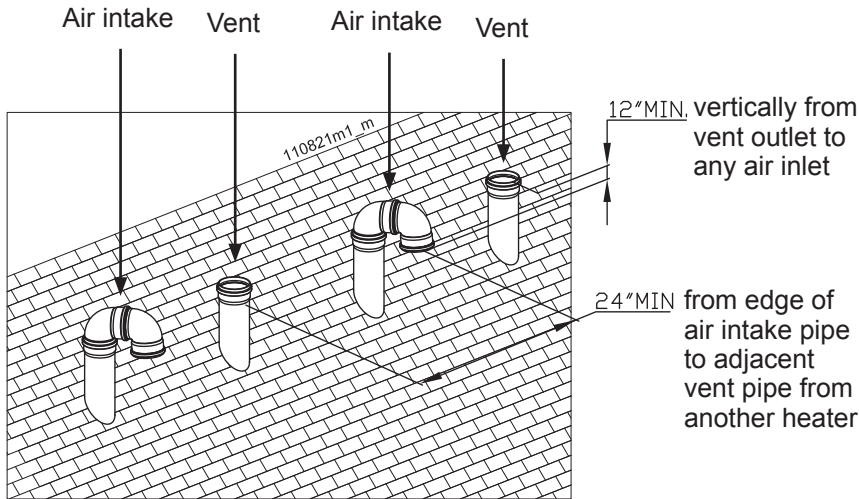

NOTICE! Keep the terminals at min. 12" from grade or snow line. Provide vent and air intake with bird screen.

Figure 12-23 Two pipes Multiple heaters vertical terminations

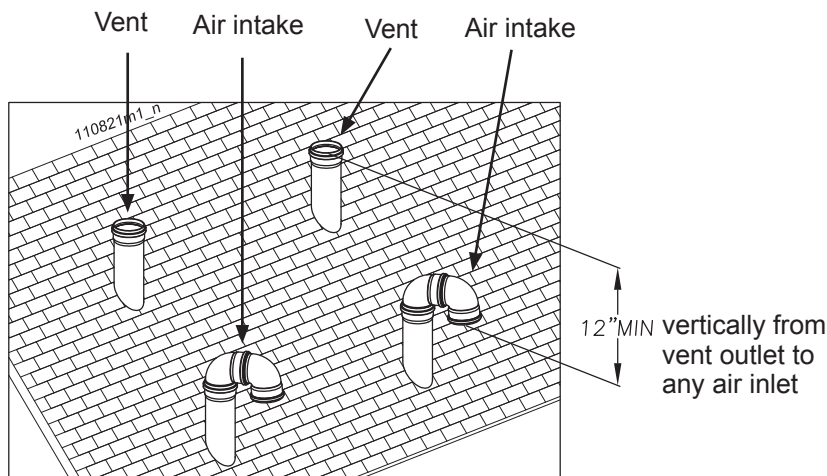

NOTICE! Keep the terminals at min. 12" from grade or snow line. Provide vent and air intake with bird screen.

Figure 12-24 Alternate vertical terminations with multiple heaters

12 - INSTALLATION - CATEGORY IV: Vent and combustion air

12.13 - Vertical termination – Concentric vent

12.13.1 - Description and usage

Both combustion air and vent pipes must attach to the termination kit. The termination kit must terminate outside the structure and must be installed as shown in Figure 12-25.

12.13.2 - Determine location

Locate the vent/air terminations using the following guidelines:

1. The total length of piping for vent or air must not exceed the limits given in Section 12.3.
2. The concentric terminal must terminate at least 3 feet above the highest place in which the vent penetrates the roof and at least 2 feet above any part of a building within 10 horizontal feet.
3. Locate termination so it is not likely to be damaged by foreign objects, such as stones or balls, or subject to buildup of leaves or sediment.

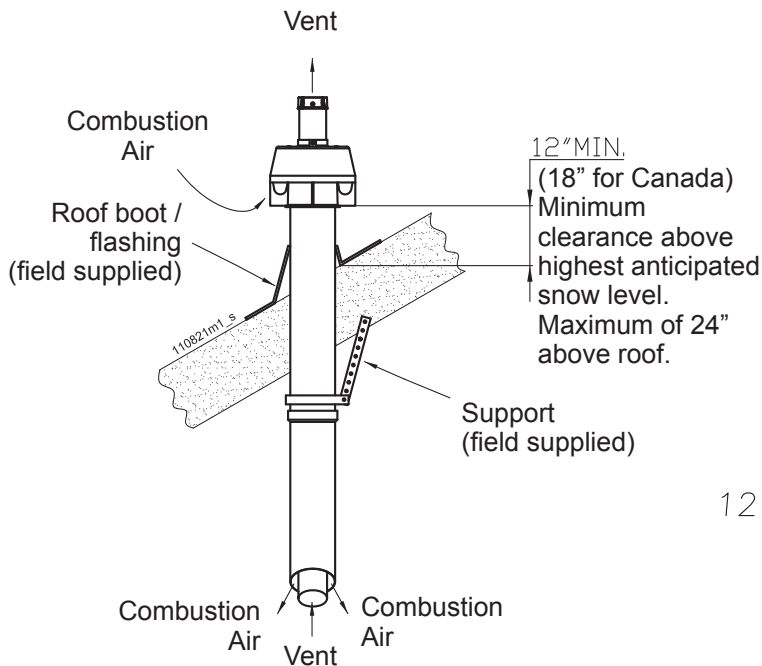

Figure 12-25 Concentric vertical terminations

12.13.3 - Vertical termination installation

1. Determine the best location for the termination kit (see Figure 12-26).
2. The total length of piping for vent or air must not exceed the limits given in Section 12.3.
3. You must consider the surroundings when terminating the vent and air:
 - a. Position the vent termination where vapors will not damage nearby shrubs, plants or air conditioning equipment or be objectionable.
 - b. The flue products will form a noticeable plume as they condense in cold air. Avoid areas where the plume could obstruct window views.
 - c. Prevailing winds could cause freezing of condensate and water/ice buildup where flue products impinge on building surfaces or plants.
 - d. Avoid possibility of accidental contact of flue products with people or animals
 - e. Do not terminate above any door or window. Condensate can freeze, causing ice formations.
 - f. Locate or guard vent to prevent condensate damage to exterior finishes.

4. Cut one (1) hole into the structure to install the termination kit.
5. Install the Concentric vent kit following the concentric kit manufacturer's instruction.

NOTICE! Ensure termination location clearance dimensions are as shown in Figures 12-25 and 12-26.

NOTICE! Ensure termination height is above the roof surface or anticipated snow level (12 inches in U.S.A. or 18 inches in Canada) as shown in Figure 12-25.

CAUTION!!! DO NOT use field-supplied couplings to extend pipes. Airflow restriction will occur and may cause intermittent operation.

6. Operate the appliance one (1) heat cycle to ensure combustion air and vent pipes are properly connected to the concentric vent termination connections.

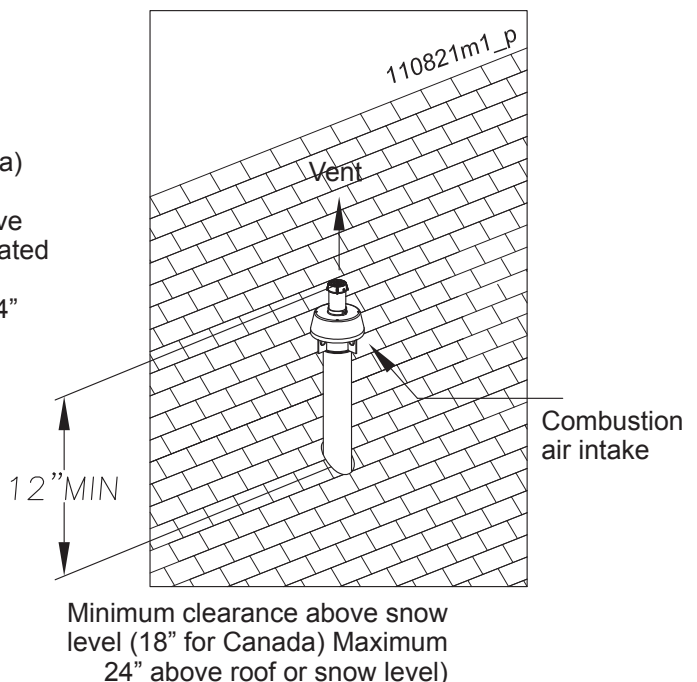

Figure 12-26 Concentric vertical terminations

12 - INSTALLATION - CATEGORY IV: Vent and combustion air

12.13.4 - Multiventing vertical terminations

When two (2) or more direct vent appliances are vented near each other, each appliance must be individually vented (see Figure 12-27).

! WARNING!!! NEVER common vent or breach vent this appliance to avoid possibility of severe personal injury, death, or substantial property damage.

When two or more direct vent appliances are vented near each other, two vent terminations may be installed as shown in Figure 12-27. It is important that vent terminations be made as shown to avoid recirculation of flue gases.

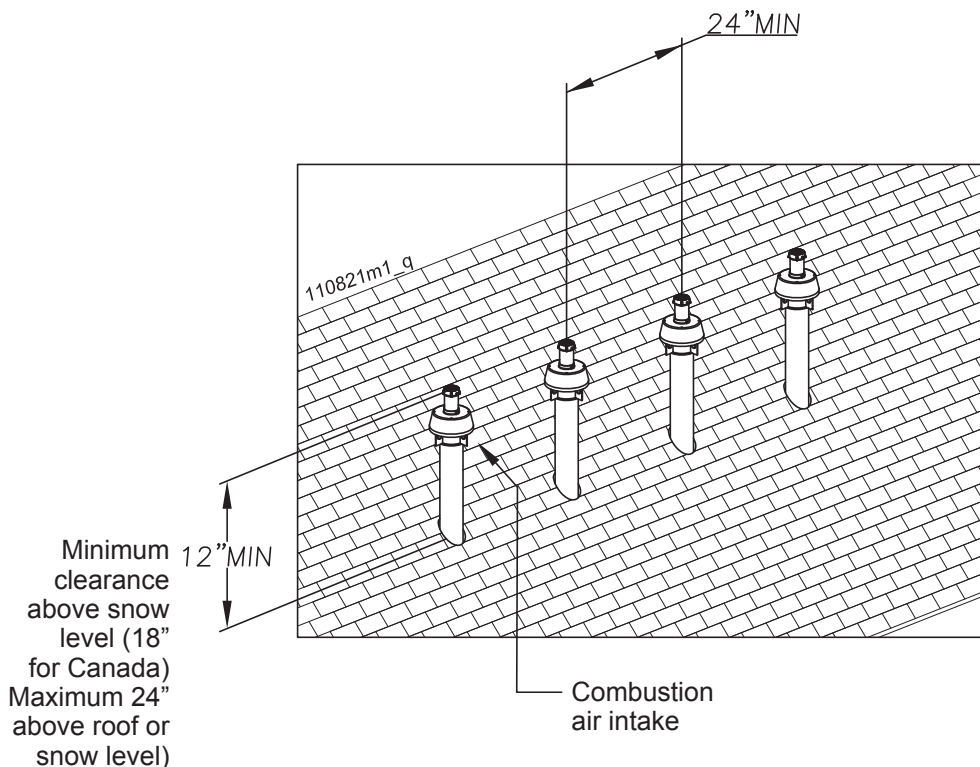

Figure 12-27 Concentric multiple heaters vertical terminations

13 - INSTALLATION - CATEGORY II: Vent and combustion air

13.1 - CAT II: Negative pressure condensing

An appliance that operates with a non-positive vent static pressure with a vent gas temperature that may cause excessive condensate production in the vent.

13.2 - CAT II: Adapter and increaser

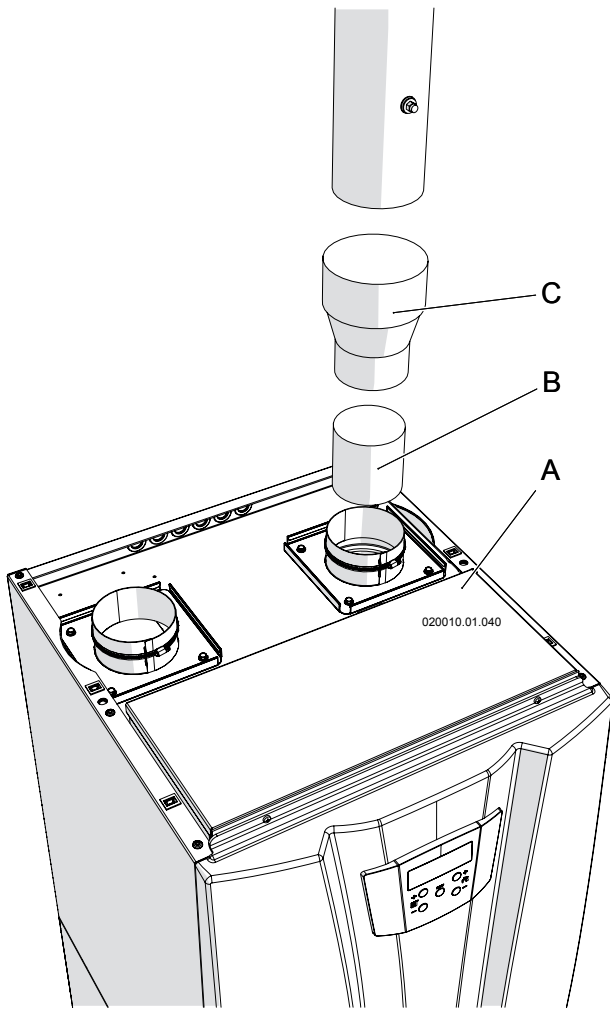

A = HEATER
B = ADAPTER
C = INCREASER

Figure 13-1 Adapter and increaser

MODEL	FLUE SIZE	FAMILY OF MATERIAL	MANUFACTURER	ADAPTER	INCREASER	AIR INLET	VENT ROOF TERMINAL
199	3" to 6"	Stainless steel	DURAVENT	810005378	810003136 + 810005375	FSBS6 + FSELB9006	FSVL 3606
399 500	4" to 8"	Stainless steel	DURAVENT	810005545	810005375 + 810005385	FSBS8 + FSELB9008	FSVL 3608
750 1000	6" to 8"	Stainless steel	DURAVENT	810005231	810005385	FSBS8 + FSELB9008	FSVL 3608

13 - INSTALLATION - CATEGORY II: Vent and combustion air

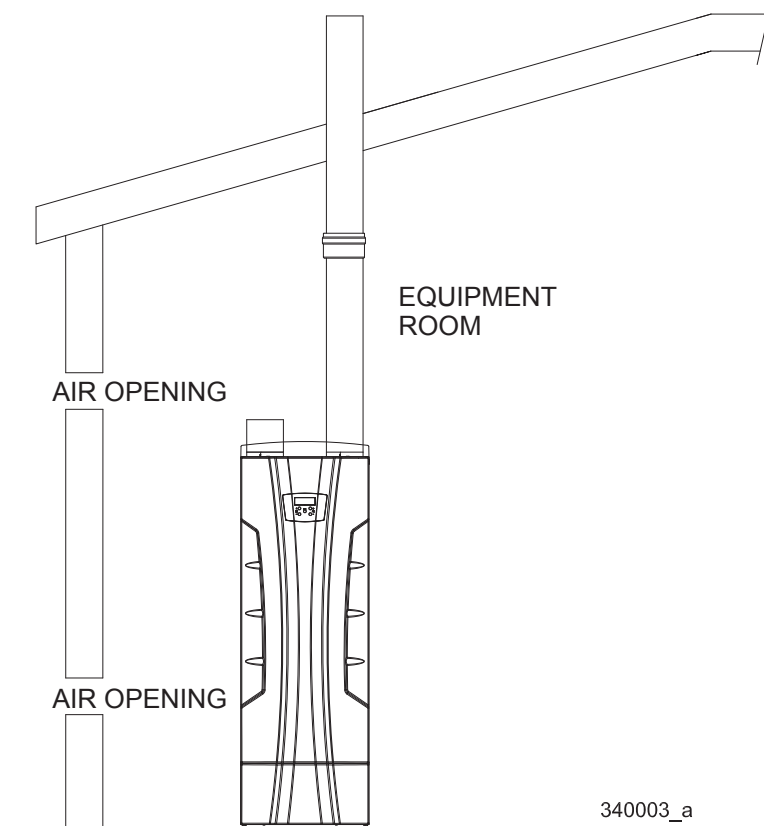

Figure 13-2 Vertical vent with combustion air from equipment room

13.3 - Condensing vent option: CATEGORY II: Vertical vent with combustion air from equipment room

The flue outlet terminates on the rooftop.

The termination point for the flue products must follow the vertical vent termination clearance requirements on section 12.12. These units can be identified by the CATEGORY II as noted on the unit's rating plate.

The flue from this category II appliance must have all vent joints and seams sealed gastight. A category II vent system has specific vent material and installation requirements.

The flue products in the vent system may be cooled below their dew point and form condensate in the flue. The materials used for a category II vent must be resistant to any corrosive damage from flue gas condensate.

Follow all requirements in section 5.1, 12.2 and 12.9. Follow all requirements for venting flue products to the outdoors with a vertical termination as per section 12.12.

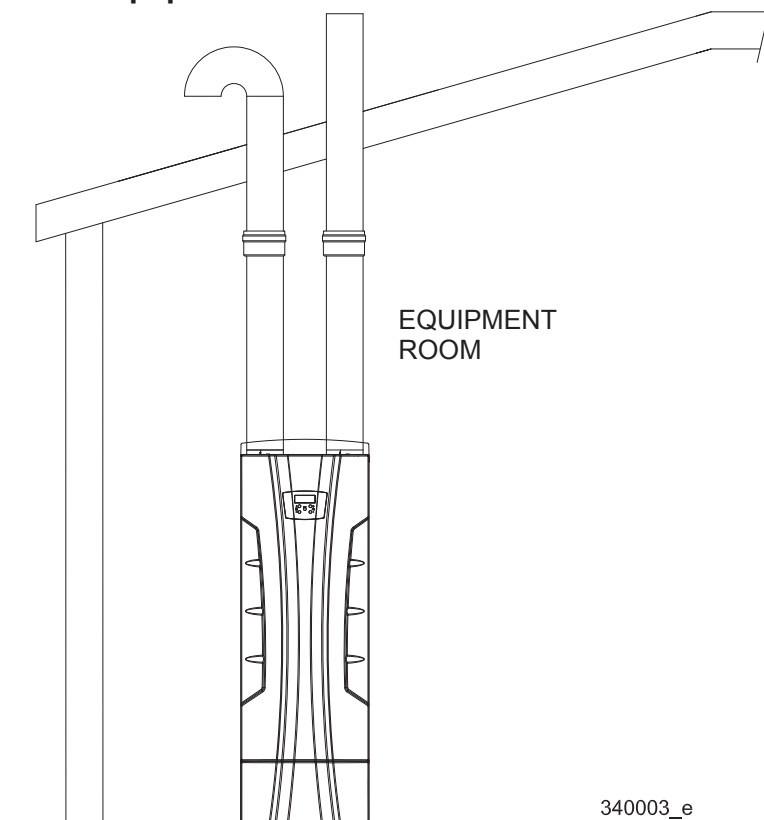

Figure 13-3 Vertical direct vent installation with rooftop combustion air inlet

Vertical direct vent installation with rooftop combustion air inlet

The vertical direct vent system is installed with a Category II flue and a separate combustion air pipe to the outdoors. The flue outlet and combustion air intake must both terminate on the rooftop.

The termination point for the flue products must follow the vertical vent termination clearance requirements on section 12.12. These units can be identified by the Category II as noted on the unit's rating plate.

Follow all requirements in sections 5.1, 12.2 and 12.9. Follow all requirements for venting flue products to the outdoors with a vertical termination as per section 12.12.

The vertical direct vent system requires the installation of an additional pipe to supply combustion air from outdoors directly to the appliance. Follow all requirements under the combustion air inlet section 12.5.

13 - INSTALLATION - CATEGORY II: Vent and combustion air

Vent/Air vertical installation with sidewall combustion air inlet

The vent/air vertical with a sidewall combustion air vent system terminates the flue at the rooftop and air inlet at the sidewall. The flue outlet and combustion air intake terminate in different pressure zones.

The termination point for the flue products must follow the vertical vent termination clearance requirements on section 12.12. These units can be identified by the Category II as noted on the unit's rating plate.

Follow all requirements in sections 5.1, 12.2 and 12.9. Follow all requirements for venting flue products to the outdoors with a vertical termination as per section 12.12.

The vent/air vertical system requires the installation of an additional pipe to supply combustion air from outdoors directly to the appliance. Follow all requirements under the combustion air inlet section 12.5.

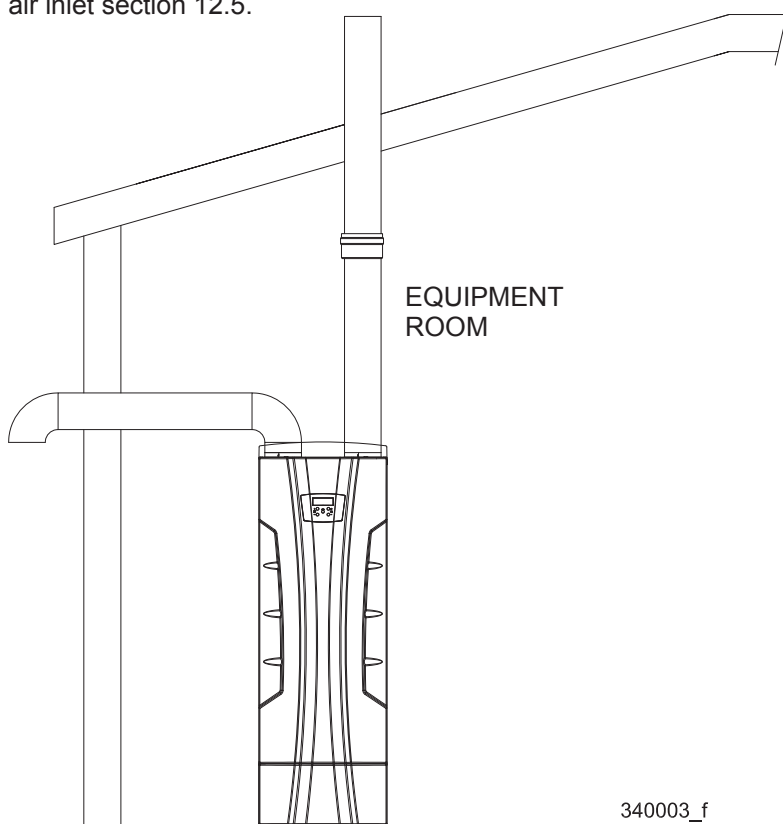

Figure 13-4 Vertical vent/air installation with sidewall combustion air inlet

Common venting CATEGORY II:

Flues of multiple water heaters may be combined by incorporating a vent increaser to change the category IV appliance to a category II vent system which can be common vented using an engineered vent system. The increaser kit must be provided by the manufacturer and the combined engineered vent system must be designed to ensure that flue products will be properly exhausted from the building at all times.

! WARNING!!! Failure to use the correct vent increaser or a properly sized vent system may result in excessive levels of carbon monoxide which can cause severe personal injury or death!

Consult a vent designer to determine the diameter of the common vent pipe required for combined vent installation. It is recommended that all vent joints and seams are sealed gashigt. This vent system has specific vent material and installation requirements. The negative draft in a conventional vent installation must be within the range of 0.02 to 0.08 inches w.c. to ensure proper operation. Make all draft readings while the unit is in stable operation (approximately 10 minutes).

! WARNING!!! Improper venting can result in excessive levels of carbon monoxide which can cause severe personal injury or death!

1. INSTALL A CARBON MONOXIDE DETECTOR. At the time of installation of the common vented gas fueled equipment, the installing plumber or gasfitter shall observe that a hard wired carbon monoxide detector with an alarm and battery back-up is installed on the floor level where the gas equipment is to be installed. It shall be the responsibility of the property owner to secure the services of qualified licensed professionals for the installation of hard wired carbon monoxide detectors.
2. APPROVED CARBON MONOXIDE DETECTORS. Each carbon monoxide detector as required in accordance with the above provisions shall comply with NFPA 720 and be ANSI/UL 2034 listed and IAS certified.

14 - INSTALLATION - Gas supply

14.1 - Gas supply piping

! WARNING!!! Check that the type and the pressure of the gas supplied correspond with those required for the heater as stated on the rating plate. **Never use a gas different than that stated on the heater rating plate. Failure to comply with this warning can result in a fire or explosion causing extensive property damage, severe personal injury or death!**

Connecting gas supply piping:

1. Refer to Figure 14-1 to pipe gas to the heater.
 - a. Install ground joint union for servicing, when required.
 - b. Install a manual shutoff valve in the gas supply piping, outside heater jacket
 - c. Manual main shutoff valves, must be identified by the installer.
2. Install sediment trap / drip leg. (see Figure 14-1).
3. Support piping with hangers, not by the heater or its accessories.

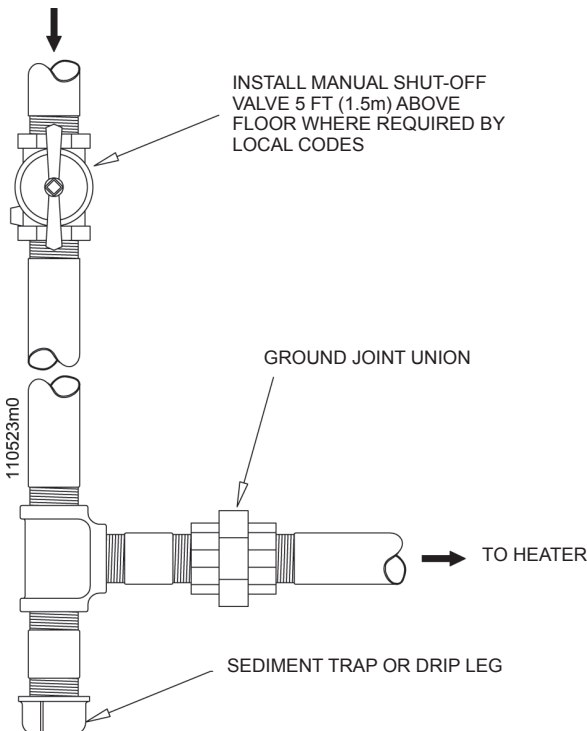

Figure 14-1 Gas supply piping

! WARNING!!! Do not attempt to support the weight of the piping with the heater or its accessories. Failure to comply could result in severe personal injury, death, or substantial property damage.

4. Purge all air from the gas supply piping.
5. Before placing the heater in operation, check the heater and its gas connection for leaks.
 - a. The appliance must be disconnected from the gas supply piping system during any pressure testing of that system at a test pressure in excess of 1/2 PSIG (3.5 kPa).
 - b. The appliance must be isolated from the gas supply piping system by closing a manual shutoff valve during any pressure testing of the gas supply piping system at test pressures equal to or less than 1/2 PSIG (3.5 kPa).
 - c. The appliance and its gas connection must be leak tested before placing it in operation.

! WARNING!!! Never use an open flame to test for gas leaks. Always use an approved leak detection method. Failure to comply with this WARNING could result in an explosion!

6. Use pipe sealing compound compatible with propane gas. Apply sparingly only to male threads of the pipe joints so that pipe dope does not block gas flow.

! WARNING!!! Failure to apply pipe sealing compound can result in severe personal injury, death, or substantial property damage.

! WARNING!!! This heater is typically shipped ready to fire on natural gas. Check heater rating plate to determine which fuel the heater is set for. If set to natural gas, it may be converted to LP following instruction on Section 14.6 or 14.7. Failure to comply could result in severe personal injury, death, or substantial property damage.

! WARNING!!! Manual main shutoff valve, must be identified by the installer. Failure to comply could result in fire or explosion that can cause severe personal injury, death, or substantial property damage.

14 - INSTALLATION - Gas supply

14.2 - Pipe sizing for natural gas

Refer to Figure 14-2 for pipe length and diameter. For additional gas pipe sizing information, refer to ANSI Z223.1 (or B149.1 for Canadian installations).

Natural gas supply pressure requirements

- Pressure required at the gas valve inlet pressure port:
 - Maximum 13"W.C. with no flow (lockup) or with heater off.
 - Minimum 3"W.C. with gas flowing (verify during high fire).
- Install 100% lockup gas pressure regulator in supply line if inlet pressure can exceed 13"W.C. at any time. Adjust lockup regulator for 13"W.C. maximum.

14.3 - Propane Gas

! WARNING!!! These heaters are typically shipped ready to fire on natural gas. Check heater rating plate to determine which fuel the heater is set for. If set to natural gas, it may be converted to LP by following instruction on Section 14.6 or 14.7. Failure to comply could result in severe personal injury, death, or substantial property damage.

Pipe sizing for propane gas

Contact gas supplier to size pipes, tanks, and 100% lockup gas pressure regulator.

Propane supply pressure requirements:

- Adjust propane supply regulator provided by the gas supplier for 13"W.C. maximum pressure.
- Pressure required at gas valve inlet pressure port:
 - Maximum 13"W.C. with no flow (lockup) or with heater off.
 - Minimum 3"W.C. with gas flowing (verify during high fire).

! WARNING!!! Ensure that the high gas pressure regulator is at least 6 - 10 ft upstream of the appliance. Failure to comply could result in severe personal injury, death, or substantial property damage.

Nominal:	Iron Pipe size (in)							
	3/4	1	1 1/4	1 1/2	2	2 1/2	3	4
Actual ID:	0.824	1.049	1.380	1.610	2.067	2.469	3.068	4.026
Length (ft)	Capacity in Cubic Feet of Gas per Hour							
10	273	514	1060	1580	3050	4860	8580	17500
20	188	353	726	1090	2090	3340	5900	12000
30	151	284	583	873	1680	2680	4740	9660
40	N/A	243	499	747	1440	2290	4050	8270
50	N/A	215	442	662	1280	2030	3590	7330
60	N/A	195	400	600	1160	1840	3260	6640
70	N/A	179	368	552	1060	1690	3000	6110
80	N/A	167	343	514	989	1580	2790	5680
90	N/A	157	322	482	928	1480	2610	5330
100	N/A	148	304	455	877	1400	2470	5040
125	N/A	131	269	403	777	1240	2190	4460
150	N/A	119	244	366	704	1120	1980	4050
175	N/A	N/A	224	336	648	1030	1820	3720
200	N/A	N/A	209	313	602	960	1700	3460
250	N/A	N/A	185	277	534	851	1500	3070

NOTICE! Maximum pipe capacity is based on a 0.60 specific gravity gas at a pressure of 0.5 PSIG and a 0.3"WC pressure drop

Figure 14-2 Gas pipe capacity for natural gas

14 - INSTALLATION - Gas supply

14.4 - Check inlet gas supply pressure

WARNING!!!

DO NOT adjust or attempt to measure gas valve outlet pressure. The gas valve is factory-set for the correct outlet pressure. This setting is suitable for natural gas and propane, requiring no field adjustment. Attempting to alter or measure the gas valve outlet pressure could result in damage to the valve, causing excessive levels of carbon monoxide, which can result in severe personal injury or death!

NOTICE! The maximum inlet gas pressure must not exceed the value specified by the manufacturer and that the minimum value listed is for the purposes of input adjustment.

The gas piping must be sized for the proper flow and length of pipe, to avoid excessive pressure drop. Both the gas meter and the gas regulator must be properly sized for the total gas load.

If you experience a pressure drop greater than 1"W.C., the meter, regulator, or gas line is undersized or in need of service.

1. Follow Section 15.7 to check the inlet gas supply pressure.
2. If gas supply pressure is within normal range and no adjustments are needed, proceed on to step 4.
3. If the gas pressure is out of range, contact the gas utility, gas supplier, qualified installer or service agency to determine the necessary steps to provide proper gas pressure to the heater.
4. Turn the power switch to the "OFF" position.
5. Shut off the manual gas shut off valve.
6. After verifying the correct gas pressures disconnect the manometer, turn the screw in pressure connection "D" in Figure 14-6, clockwise until snug and check for any gas leaks.

CAUTION!!! Never force the pressure connection screw or the gas valve will be damaged!

WARNING!!! Never use an open flame to check for gas leaks, or a fire or an explosion could result causing severe personal injury or death!

14.5 - Operating at high altitudes

For installations in the United States:

the heater is rated for operation at altitudes up to 10,000 ft (3078 m). For altitude above 2,000 ft (610 m) check and adjust the CO₂ level following Section 15.8. This will result in an automatic input downrate of 3% each 1,000 ft (305 m) altitude.

For installation in Canada:

the heater is rated for operation at altitudes up to 4,500 ft (1372 m). For altitude above 2,000 ft (610 m) check and adjust the CO₂ level following Section 15.8. This will result in an automatic input downrate of 3% each 1,000 ft (305 m) altitude.

14 - INSTALLATION - Gas supply

14.6 - Convert a heater model 199 from Natural Gas to Propane gas or viceversa



WARNING!!!

The

conversion shall be carried out in accordance with the requirements of the provincial authorities having jurisdiction and in accordance with the requirements of the *CAN-B149.1* and *CAN1-B149.2 installation code*.



WARNING!!!

The gas conversion shall be performed by a qualified service agency in accordance with this instructions and all applicable codes and requirements of the authority having jurisdiction. The information in these instructions must be followed to minimize the risk of fire or explosion or to prevent property damage, personal injury or death. The qualified service agency is responsible for the proper conversion of the heater. The installation is not proper and complete until the operation of the converted appliance is checked as specified in this instructions.

Contents:

The conversion kit (supplied with the heater) is composed of the following elements, which are necessary for the gas change:

- a label rating stating the new gas setting;
- an instruction sheet;
- an orifice per each burner present on the unit;

Installing:

in order to make the gas change follow the instructions below:

- 1 - turn off the power to the heater;
- 2 - close the manual gas shut off valve;
- 3 - dismantle the jacket of the heater, follow Section 17.2;
- 4 - unscrew nut "H" as per Figure 14-3;
- 5 - with the help of a screwdriver, remove spring "A" (see figure 14-3);
- 6 - remove the gas valve from its site "C" as per Figure 14-4 (take care attention to o-ring "L" of Figure 14-4);
- 7 - replace orifice "G" of Figure 14-5, for the correct one for type of gas used. Verify that the stamping on the orifice matches the Figure 14-7;
- 8 - reinstall the gas valve, paying close attention to the o-ring "L" of Figure 14-4 and to the gasket between gas valve and nut "H" of Figure 14-3;
- 9 - Insert again the spring "A" of Figure 14-3;
- 10 - tight nut "H" of Figure 14-3;
- 11 - open the manual gas shut off valve;
- 12 - check for any gas leaks on nut "H" of Figure 14-3;

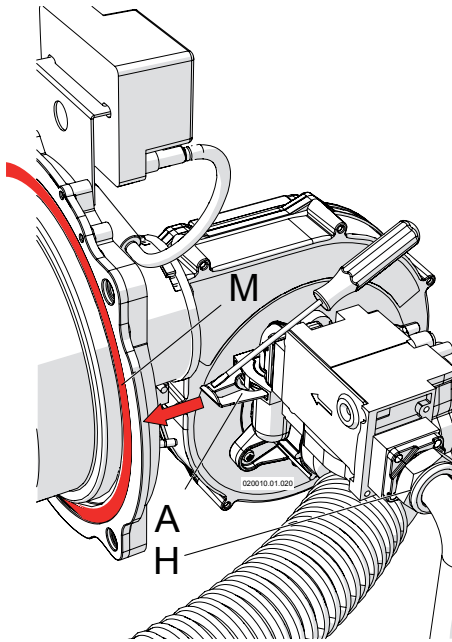

Figure 14-3 Dismantle the gas valve

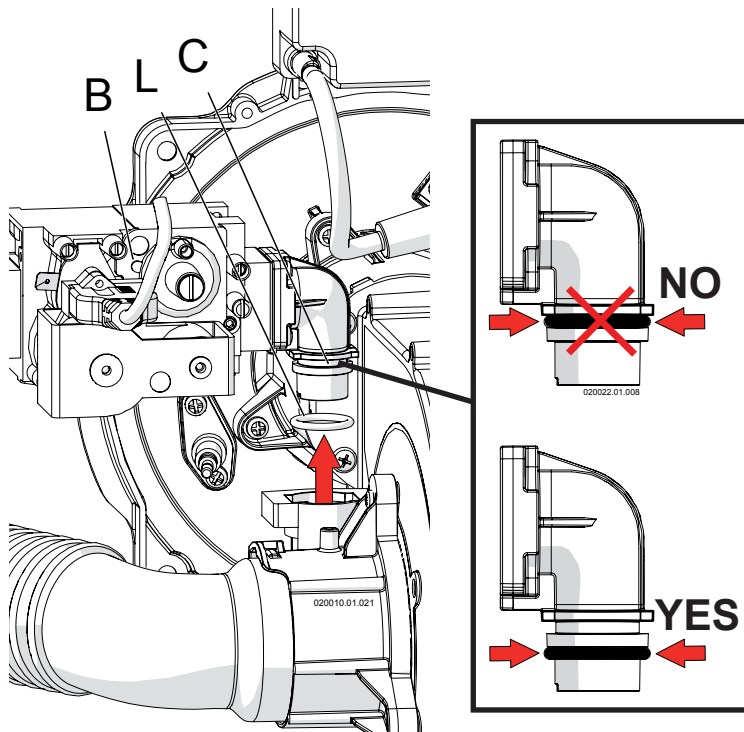

Figure 14-4 Lift the gas valve

14 - INSTALLATION - Gas supply

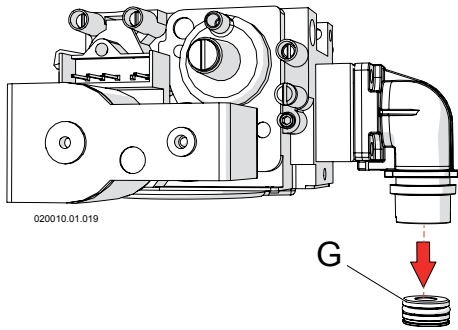

Figure 14-5 Gas orifice

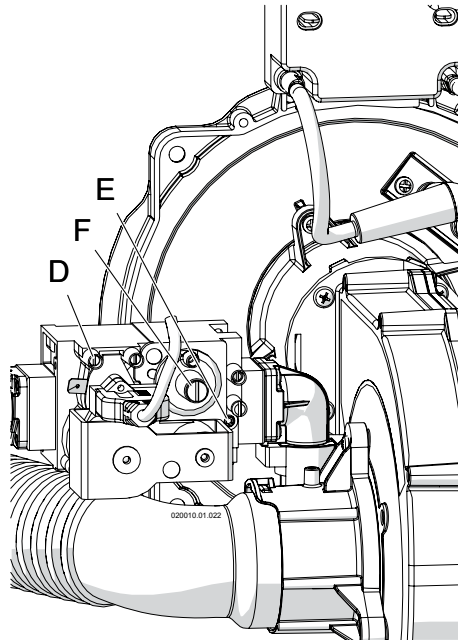

Figure 14-6 Gas valve

! WARNING!!! Never use an open flame to check for gas leaks, a fire or an explosion could result causing severe personal injury or death!

- 13 - turn the power on to the heater;
- 14 - turn completely counter clockwise the screw "E" of Figure 14-6;
- 15 - Checking gas supply pressure following Section 15.7. The minimum gas supply pressure must not be less than 3"WC (7.6 mbar) and the maximum gas supply pressure must not be higher than 13"WC (33 mbar).
- 16 - Verifying the CO₂ rate and its eventual adjustment following Section 13.8: The heater during its normal operation, within a maximum altitude of 2,000 ft, has a CO₂ exhaust rate as shown in Figure 14-7. If not within range of value shown, malfunctions will occur.

! WARNING!!! The CO (carbon monoxide) level should not exceed values given in Figure 14-7, when combustion is correct. Failure to comply with this requirement could result in severe personal injury, death or substantial property damage.

! WARNING!!! All combustion measurements must be performed with calibrated equipment to ensure proper reading and accuracy. Failure to comply with this requirement could result in severe personal injury, death or substantial property damage.

! WARNING!!! If the combustion levels are not within the range given in Figure 14-7 for the firing rate, shut the heater down and contact your distributor or the heater manufacturer (see reference in the last cover page). Failure to comply with this requirement could result in severe personal injury, death or substantial property damage.

- 17 - check the capacity of the heater following Section 15.9;
- 18 - Attach to the front of the heater the appropriate conversion label, found in the conversion kit (see Figure 14-8 or Figure 14-9), stating the new type of gas adjustment of the heater.
 - a - Apply the label in Figure 14-8 if the heater has been converted to **LP GAS**;
 - b - Apply the label in Figure 14-9 if the heater has been converted to **NATURAL GAS**.

	U.M	199	399	500	750	1000
Orifice stamping for Natural gas	mm/100	No orifice	No orifice	930	930	930
Orifice stamping for LP gas	mm/100	700	700	700	700	700
CO ₂ (Carbon dioxide) for Natural gas at high fire	%	8.4 to 8.7	8.4 to 8.7	8.8 to 9.1	8.8 to 9.1	8.8 to 9.1
CO ₂ (Carbon dioxide) for Natural gas at low fire	%	8.4 to 8.7	8.4 to 8.7	8.8 to 9.1	8.8 to 9.1	8.8 to 9.1
CO ₂ (Carbon dioxide) for LP gas at high fire	%	9.5 to 10				
CO ₂ (Carbon dioxide) for LP gas at low fire	%	10.5 to 11.5				
O ₂ (Oxygen) for Natural gas at high fire	%	5.9 to 5.4	5.9 to 5.4	5.2 to 4.7	5.2 to 4.7	5.2 to 4.7
O ₂ (Oxygen) for Natural gas at low fire	%	5.9 to 5.4	5.9 to 5.4	5.2 to 4.7	5.2 to 4.7	5.2 to 4.7
O ₂ (Oxygen) for LP gas at high fire	%	6.4 to 5.6				
O ₂ (Oxygen) for LP gas at low fire	%	4.8 to 3.4				
CO (Carbon monoxide) for Natural gas at high and low fire	ppm	Less than 150				
CO (Carbon monoxide) for LP gas at high and low fire	ppm	Less than 250				

Figure 14-7 Settings of the heater for NATURAL GAS and LP GAS

14 - INSTALLATION - Gas supply

14.7 - Convert a heater model 399, 500, 750 or 1000 from Natural Gas to Propane gas or viceversa

Appliances model 399, 500, 750 or 1000 are multiburner appliances. This means that the gas conversion must be performed on each burner present inside the unit.

! WARNING!!! The gas conversion shall be performed by a qualified service agency in accordance with this instructions and all applicable codes and requirements of the authority having jurisdiction. The information in these instructions must be followed to minimize the risk of fire or explosion or to prevent property damage, personal injury or death. The qualified service agency is responsible for the proper conversion of the heater. The installation is not proper and complete until the operation of the converted appliance is checked as specified in this instructions.

! WARNING!!! The conversion shall be carried out in accordance with the requirements of the provincial authorities having jurisdiction and in accordance with the requirements of the *CAN-B149.1* and *CAN1-B149.2* installation code.

Contents:

The conversion kit (supplied with the heater) is composed of the following elements, which are necessary for the gas change:

- a label rating stating the new gas setting;
- an instruction sheet;
- an orifice per each burner present on the unit;

Installing:

in order to make the gas change please follow the instructions below:

1. operate to convert the "Burner 1 (Master)". See Figures 3-7 and 3-10 to identify "Burner 1 (Master)";
2. operating on "Burner 1 (Master)" following exactly Section 14.6 from point 1. to 16.;

After converting "Burner 1 (Master)" you have to operate on "Burner 2" (See Figure 3-7 and 3-10) and:

3. follow exactly Section 14.6 from point 1. to 16.;

After converting "Burner 2" you have to operate on "Burner 3", if present (See Figure 3-7 and 3-10), and:

4. follow exactly Section 14.6 from point 1. to 16.;

After converting "Burner 3" you have to operate on "Burner 4", if present, (See Figure 3-7 and 3-10) and:

5. follow exactly Section 14.6 from point 1. to 16.;

After converting all burners:

6. check the inlet gas pressure of the unit, following Section 15.7;
7. check the capacity input of the unit following Section 15.9;
- 8 - Attach to the front of the heater the appropriate conversion label, found in the conversion kit stating the new type of gas adjustment of the heater as follow:
 - a - Apply the label in Figure 14-8 if the heater has been converted to **LP GAS**;
 - b - Apply the label in Figure 14-9 if the heater has been converted to **NATURAL GAS**.

ATTENTION!!!

This heater has been converted for use with **LP GAS**

- Maximum inlet gas pressure: 13 In.W.C.
- Minimum inlet gas pressure: 3 In.W.C.
- Manifold pressure: (see rating plate)
- Input rating: (see rating plate)

This water heater was converted on (day-month-year) _____ to _____ gas with kit n° _____ by _____

(name and address of organization making this conversion, who accepts the responsibility for the correctness of this conversion).

62491139.01

Figure 14-8 Label for LP gas heater

ATTENTION!!!

This heater has been converted for use with **NATURAL GAS**

- Maximum inlet gas pressure: 13 In.W.C.
- Minimum inlet gas pressure: 3 In.W.C.
- Manifold pressure: (see rating plate)
- Input rating: (see rating plate)

This water heater was converted on (day-month-year) _____ to _____ gas with kit n° _____ by _____

(name and address of organization making this conversion, who accepts the responsibility for the correctness of this conversion).

62491125.01

Figure 14-9 Label for Natural gas heater

15 - START-UP

15.1 - Operating

Before starting the heater, the following must be done.

15.1.1 - User instructions

The user must be correctly instructed by the installer, on how to operate the heater, in particular:

- ☞ Make sure that the user understands that combustion air and ventilation openings must not be restricted/ closed/ or modified in any way.
- ☞ Make sure that the user is informed of all the special measures to be taken for combustion air inlet and discharging flue gases, and that these must not be modified in any way.
- ☞ Make sure that the user keeps this manual and all other documentation included with the heater.
- ☞ Make sure that the user understands never to tamper with gas control settings and the risk of CO poisoning should an unauthorized individual do so.
- ☞ Make sure that the user knows how to adjust temperatures, controls and the room thermostats for maximum efficiency.

15.1.2 - Filling the condensate and neutralizing box

The condensate and neutralizing box is positioned inside the heater as shown in Figures 3-3 through 3-9, item "3". It must be filled with water to prevent the leakage of flue gases from the condensate drainpipe, item "5" in Figures 3-3 through 3-9. To fill and inspect the condensate box proceed follow Section 17.6.

! WARNING!!! If heater stays off for more than 3 months, repeat the above operation to again fill the condensate trap. Failure to follow this warning could result in excessive levels of carbon monoxide, which can result in severe personal injury or death!

15.1.3 - Filling the heating system on a IB boiler

! WARNING!!! Never use non-approved additives or toxic heater treatment chemicals in the heating system as they can cause serious health problems or possibly death. Any additives introduced into the heating system must be recognized as safe by the United States Food and Drug Administration.

! CAUTION!!! The heating system must be filled with clean water and with maximum hardness of TDS 200 ppm. Contaminated or harder water can damage the heat exchanger.

! CAUTION!!! The water's pH must fall within the following limit: $7.5 < \text{pH} < 9.5$ and if the system contains aluminium parts, it must be $7.5 < \text{pH} < 8.5$. This pH value must be measured after steady condition and after air purging operations has been done (death water condition). Water out from the above pH values can result in premature heat exchanger damage.

To fill the heating system, proceed as follows:

1. open any automatic air vent in the heating system;
2. open the fill valve and proceed to fill the heating system and boiler until the pressure gauge, item "M" in Figure 16-1, reads the correct pressure for the heating system size and "Err 59" disappears from the display; ("Err 59" displaying is set at 15PSI. If you want to increase the "Err 59" intervention level, set parameter 3022 to the desired value (See Section 21)
3. check that there is no water leaking from the fittings. If there is, the leaks must be eliminated;
4. close the fill valve;

5. check the pressure gauge during the purging process. If the pressure has dropped, re-open the fill valve to bring the pressure back to the desired value.

15.2 - General warnings concerning gas supply

When starting up the heater for the first time the following must be checked:

- ☞ That the heater is supplied with the type of fuel that it is configured to use. Read Section 14.
- ☞ That the gas supply system is provided with all the safety devices and controls required under current national and local codes.
- ☞ That the vent and combustion air terminals are properly connected (see Sections 12 and 13) and free from any blockages.
- ☞ That the condensate drain tube is properly connected (see Section 9).

! CAUTION!!! To avoid corrosion inside heat exchanger, gas used should have sulphur rates inside maximum annual peak over a short period of time of 150 mg/m³ and an annual average of 30 mg/m³.

! WARNING!!!

If you smell gas:

- Do not try to light any appliance.
 - Do not touch any electrical switch. Do not use any phone in your building.
 - Immediately call your gas supplier from a neighbor's phone. Follow the gas supplier's instructions.
 - If you cannot reach your gas supplier, call the fire department.
- Failure to follow the above steps can result in a fire or explosion causing property damage, personal injury or loss of life!

15 - START-UP

15.3 - Confirming the heater's gas type

The type of gas and the gas supply pressure that the heater is set up for is listed on the rating label.

The heater can operate using one of the following two gases:

NATURAL GAS

Maximum supply pressure = 13 in.W.C. (33.0 mbar).

Minimum supply pressure = 3 in.W.C. (7.6 mbar).

or

LP Gas

Maximum supply pressure = 13 in.W.C. (33.0 mbar).

Minimum supply pressure = 3 in.W.C. (7.6 mbar).

15.4 - Gas type conversion





If the gas available at the installation site is not the type the heater is configured to use, the heater must be converted. Special conversion kits are available for this purpose inside the heater. Follow instruction on Sections 14.6 and 14.7.

! WARNING!!! Conversion of the heater to use another type of gas must be carried out by a qualified technician. Improper conversion of the heater could result in a fire or an explosion causing severe personal injury or death!



15.5 - Start-up

15.5.1 - Start-up of the IB boiler

1. Open the manual gas shut off valve (Figure 14-1).
2. Switch the on/off power switch, item "T" in Figure 16-1, to "on".

3. The heater will fire only when the room thermostat calls for heat and the heating temperature settings is higher than the actual supply temperature. Press buttons  or  to select the desired heating temperature. If the external temperature sensor is connected (See Section 10.1.3), check that the calculated temperature (See Section 16.13, parameter 1012 or parameter 1107 for heater models 399 to 1000) is higher than the actual heater temperature and that the outdoor temperature (See Section 16.13, parameter 1004) is lower than "warm weather shut down temperature", (parameter 2020 into Section 16.14).
4. If the heater is connected to an indirect water heater (See Section 7.2.6) press buttons  and  to select the desired domestic hot water temperature.
5. If the display gives a Low water flow error (see Section 16.17), repeat the air purging operations.



15.5.2 - Start-up of the IW water heater

1. Open the manual gas shut off valve (Figure 14-1).
2. Switch the on/off power switch, item "T" in Figure 16-1, to "on".
3. The heater will fire only when the supply temperature settings is higher than the actual supply temperature. Press buttons  or  to select the desired supply temperature.
4. If the display gives a Low water flow error (see Section 16.17), repeat the air purging operations.

15.6 - Ignition control testing

After placing the heater in operation, the ignition control's safety shutoff function must be tested as follow:

1. turn the power switch (item "T" in Figure 16-1) to on;
2. follow Section 15.5 to create a call for heat;

3. wait a few minutes for the burner to light-up as indicated by icon . On units model 399 and 500, wait until icons ① and ② are present on the display. On units model 750 wait until icons ① ② and ③ are displayed. On units model 1000 wait until icons ① ② ③ and ④ are displayed.
 4. close the manual gas shutoff valve, see Figure 14-1;
 5. after 3 minutes, the display must show Loc 01 and  or, on models 399 to 1000 all burners icons will blinking and the icon  is displayed;
- NOTICE!** On unit models 750 and 1000, because they have 3 and 4 burners, the time to see all burners icons blinking, can arrive at 15 - 20 minutes
6. open the manual gas shutoff valve, see Figure 14-1;
 7. verify your gas meter. Gas flow must be zero.

! WARNING!!! If gas flow occurs, close the manual gas shutoff valve and troubleshoot the system to determine why there is gas flow when the gas valve should be de-energized. Do not operate the heater until the problem is resolved or a fire or explosion causing property damage, personal injury or loss of life may occur!

15 - START-UP

15.7 - Gas supply pressure checking

⚠ WARNING!!! DO NOT adjust or attempt to measure gas valve outlet pressure. The gas valve is factory-set for the correct outlet pressure. This setting is suitable for natural gas and propane, requiring no field adjustment. Attempting to alter or measure the gas valve outlet pressure could result in damage to the gas valve, causing excessive levels of carbon monoxide, which can cause severe personal injury or death!

Check the gas supply pressure by following the steps below:

1. close the manual gas shut-off valve, Figure 14-1;
2. follow the steps in Section 17.2 to remove the front cover;
3. turn the screw in pressure port "D" shown in Figure 15-1 three turns counterclockwise;

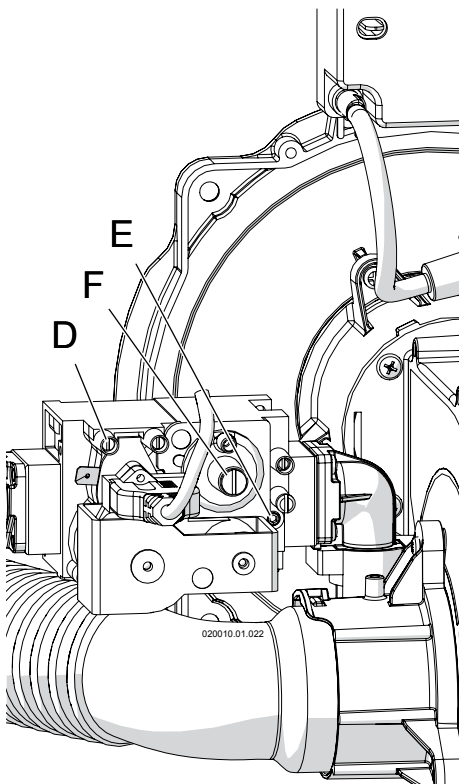



Figure 15-1 Gas valve

4. connect a manometer with graduations of at least 0.1 in.W.C. (0.25 mbar) to the inlet gas port "D" shown in Figure 15-1 (on unit model 399 to 1000, choose the pressure port "D" from any gas valve present).
5. open the manual gas shut off valve, Figure 14-1;
6. check that the gas supply pressure does not exceed 13 in.W.C. If the gas supply pressure is higher than 13 in.W.C. adjust the upstream gas pressure regulator to bring the gas supply pressure between 12"WC and 13"WC;
7. turn the power switch to on and generate a heat demand by pressing button  to its maximum setting. Also ensure that the room thermostat is calling for heat and operate downstream the unit to verify the system is able to dissipate all heat generated.
8. set parameter 2200 to "HIGH" (see section 16.14) (for boiler model 199 use parameter 2010). All burners will now start to run at high fire.
9. check the manometer to make sure the gas supply pressure does not

drop below 3 in.W.C. (7.6 mbar). If the gas supply pressure is lower than 3 in.W.C. means that your inlet gas line or your gas pressure regulator are not correctly sized;

CAUTION!!! Do not attempt to adjust your upstream gas pressure regulator. This was already adjusted for the maximum inlet gas pressure.

After verifying the correct gas pressures:

1. back to set parameter 2200 to "OFF" (on models 199 back to set parameter 2010 to "OFF"). Now heater will back to work in normal condition;
2. disconnect the manometer;
3. turn the screw in pressure connection "D" in Figure 15-1, clockwise until snug;
4. check pressure port "D" (Figure 15-1) for any gas leaks;

CAUTION!!! Never force the pressure connection screw or the gas valve will be damaged!

⚠ WARNING!!! Never use an open flame to check for gas leaks, a fire or an explosion could result causing severe personal injury or death!

5. close the manual gas shut-off valve, Figure 14-1.

D - Inlet gas pressure probe
E - CO2 adjusting screw
F - Factory adjusted regulator (Should never be touched)

15 - START-UP

15.8 - Checking and adjusting CO2 levels

Figure 14-7 lists the correct CO2 ranges for a heater running at normal operating conditions at an altitude below 2,000 ft (610m). CO2 values outside of the ranges given in Figure 14-7 may lead to malfunctioning of the heater and cause it to prematurely fail. To check the CO2 value, carry out a combustion analysis follow Section 15.8.1 or 15.8.2.

15.8.1 - Checking CO2 level on unit model 199

! WARNING!!! During this procedure compare also CO (carbon monoxide) reading, with the value given in Figure 14-7. If this is higher, STOP the heater and call the Factory service department (see phone number on the last cover page). Failure to comply with this requirement could result in severe personal injury, death or substantial property damage.

1. If it is not already present, create a combustion analysis probe site at 8" after the flue gas exhaust connection (see Figures 12-9, 12-11 or 12-13, item "H"). To do so, follow the vent pipe manufacturers' instruction.
2. generate a call for heat and wait until the heater is firing;
3. gain access to the "Installers' menu" and set parameter 2010 to HIGH (see Section 16.14). The heater will now run for 20 minutes at high fire input;
4. wait 2 to 3 minutes for the CO2 to stabilize;
5. insert the probe of a calibrated combustion analyzer into the combustion analysis probe "H" of Figures 12-9, 12-11 or 12-13 and take a flue gas sample;
6. compare the CO2 reading with the high fire range given in Figure 14-7,

making sure to use the range for the gas type in use. If the CO2 reading is outside the specified range, it must be adjusted operating on the "E" screw of Figure 15-1. Use a 2.5mm Allen Wrench to turn the screw (clockwise to reduce the CO2 level, counter-clockwise to increase the CO2 level) in small increments and wait for the CO2 to stabilize to prevent overshooting the desired value;

7. when CO2 level match the value of Figure 14-7, seal screw "E" with red paint or nail polish to discourage tampering.
8. set value of parameter 2010 to LOW. The heater will now run for 20 minutes at low fire input;
9. wait 2 to 3 minutes for the CO2 to stabilize;
10. compare the CO2 reading with the low fire range given in Figure 14-7, making sure to use the range for the gas type in use. The CO2 reading must be inside the specified range; If not, STOP the heater and call the Factory service department (see phone number on the last cover page).
11. set parameter 2010 to OFF to return the heater to its normal operating mode.
12. close the combustion analysis probe "H" of Figures 12-9, 12-11 or 12-13 with a suitable cap in accordance with the vent pipe manufacturers' instruction.

! WARNING!!! Once the cap "L" of Figures 12-9, 12-11 or 12-13 is right in place, with the heater at high fire, check that it is absent from leakage and is mechanically fixed. Improper cap fixing can result in excessive levels of carbon monoxide which can result in severe personal injury or death!

15.8.2 - Checking CO2 level on units model 399 up to 1000

! WARNING!!! During this procedure compare also CO (carbon monoxide) reading, with the value given in Figure 14-7. If this is higher, STOP the heater and call the Factory service department (see phone number on the last cover page). Failure to comply with this requirement could result in severe personal injury, death or substantial property damage.

1. If it is not already present, create a combustion analysis probe site at 8" after the flue gas exhaust connection (see Figures 12-9, 12-11 or 12-13 item "H"). To do so, follow the vent pipe manufacturers' instruction.
2. Set parameter 2200 to "HIGH" (see section 16.14). Now all burners will run at high fire for 20 minutes;
3. wait 2 to 3 minutes the CO2 to stabilize.
4. Insert the probe of a calibrated combustion analyzer into the combustion probe "H" of figures 12-9 or 12-11 or 12-13, and take a flue gas sample.
5. compare the CO2 reading with the high fire range given in Figure 14-7, making sure to use the range for the gas type in use. If the CO2 reading is outside the specified range, it must be adjusted operating on each burner. Set parameter 2200 to OFF and follow the sequent procedure:
 - a. keep the heater in stand-by by removing any call for heat (remove the jumper or any wires from terminals 10 and 11 inside the junction box or set the heating service to off by pushing on the  button up to see the OFF word);
 - b. gain access to the Installer menu and set parameter 2201 to HIGH (see Section 16.14). Now the "Burner 1 (Master)" will run for 20 minutes at high fire input;
 - c. wait 2 to 3 minutes for the CO2 to stabilize;

15 - START-UP

- d. insert the probe of a calibrated combustion analyzer into the combustion analysis probe "H" of Figures 12-9, 12-11 or 12-13 and take a flue gas sample;
- e. compare the CO₂ reading with the high fire range given in Figure 14-7, making sure to use the range for the gas type in use. If the CO₂ reading is outside the specified range, it must be adjusted operating on the "E" screw of Figure 15-1 of the gas valve closer to the burner unit in fire. Use a 2.5mm Allen Wrench to turn the screw (clockwise to reduce the CO₂ level, counter-clockwise to increase the CO₂ level) in small increments and wait for the CO₂ to stabilize to prevent overshooting the desired value;
- f. when CO₂ level match the value of Figure 14-7, seal screw "E" (Figure 15-1) with red paint or nail polish to discourage tampering.
- g. set value of parameter 2201 to LOW. The Burner 1 (Master) will now run for 20 minutes at low fire input;
- h. wait 2 to 3 minutes for the CO₂ to stabilize;
- i. compare the CO₂ reading with the low fire range given in Figure 14-7, making sure to use the range for the gas type in use. The CO₂ reading must be inside the specified range; If not, STOP the heater and call the Factory service department (see phone number on the last cover page).

CAUTION!!! The CO₂ reading, at low fire, could be affected by the natural draught of the chimney (negative pressure inside the chimney). If this is the case, take the CO₂ reading removing the correspondent flue gas sensor (item 28 of figures 3-4, 3-7 or 3-10)

- i. set parameter 2201 to "OFF", to return the Burner 1 (MASTER) to its normal running mode.
6. check the CO₂ value on all other burners follow steps as described in sections (a through I) taking in consideration that for the Burner 2

- you have to use parameter 2202, for Burner 3, parameter 2203 and for Burner 4 parameter 2204;
7. turn off the main power to the appliance;
 8. close the combustion analysis probe "H" of Figures 12-9, 12-11 or 12-13 with a suitable cap in accordance with the vent pipe manufacturers' instruction.

! WARNING!!! Once the cap "L" of Figures 12-9, 12-11 or 12-13 is right in place, with the heater at high fire, check that it is absent from leakage and is mechanically fixed. Improper cap fixing can result in excessive levels of carbon monoxide which can cause severe personal injury or death!

15.9 - Check the capacity input

The heater has a factory-set air/gas ratio. The pressure of the gas at the burner is indirectly controlled by the blower. The only way to check the heater capacity input is operating directly on the gas meter. To do so proceed as follow:

1. turn the power switch (item "T" in Figure 16-1) to on and perform a call for heat by pressing button  to its highest settings and operate downstream the unit to verify the system is able to dissipate all heat generated.
2. On unit model 199, gain access to the installer menu (See Section 16.14) and set parameter 2010 to HIGH. For models 399 to 1000, set parameter 2200 to "HIGH". Now boiler will run at high fire for 20 minutes. Be sure the heating system is able to dissipate all energy.
3. measure the capacity input to the gas meter. This should match with the value given in Section 18 header "Maximum heat input" with a tolerance of +/- 10%. (For the calculation of the btu/hr, for Natural gas, multiply the measured flow in ft³/hr by 1075. For LP gas multiply the measured flow in ft³/hr by 2500).

4. if the capacity input is too low, check:
 - a) that there are no obstructions in the combustion air and/or vent systems;
 - b) check that the flue and air intake length match with the rules of Section 12.3.;
 - c) check that the inlet air filter (see Figure 17-9 item B) is clean;
5. if the capacity input is within tolerance, bring parameter 2010 to OFF to return the heater to its normal running mode. On models 399 to 1000 set parameter 2200 to "OFF" to return the heater to its normal running mode;
6. if the capacity input is higher than the expected value, repeat the procedure as per Section 15.8.

15.10 - Minimum water flow

This unit is self protected against low water flow. A water flow meter (item "16", Figure 3-1) monitors continuously the water flow to each heat exchanger. If the water flow decrease below 11 GPM (models 199 and 399) or 12 GPM (models 500, 750 and 1000), the burner automatically shuts Off and after 3 minutes an error is displayed.

16 - USE

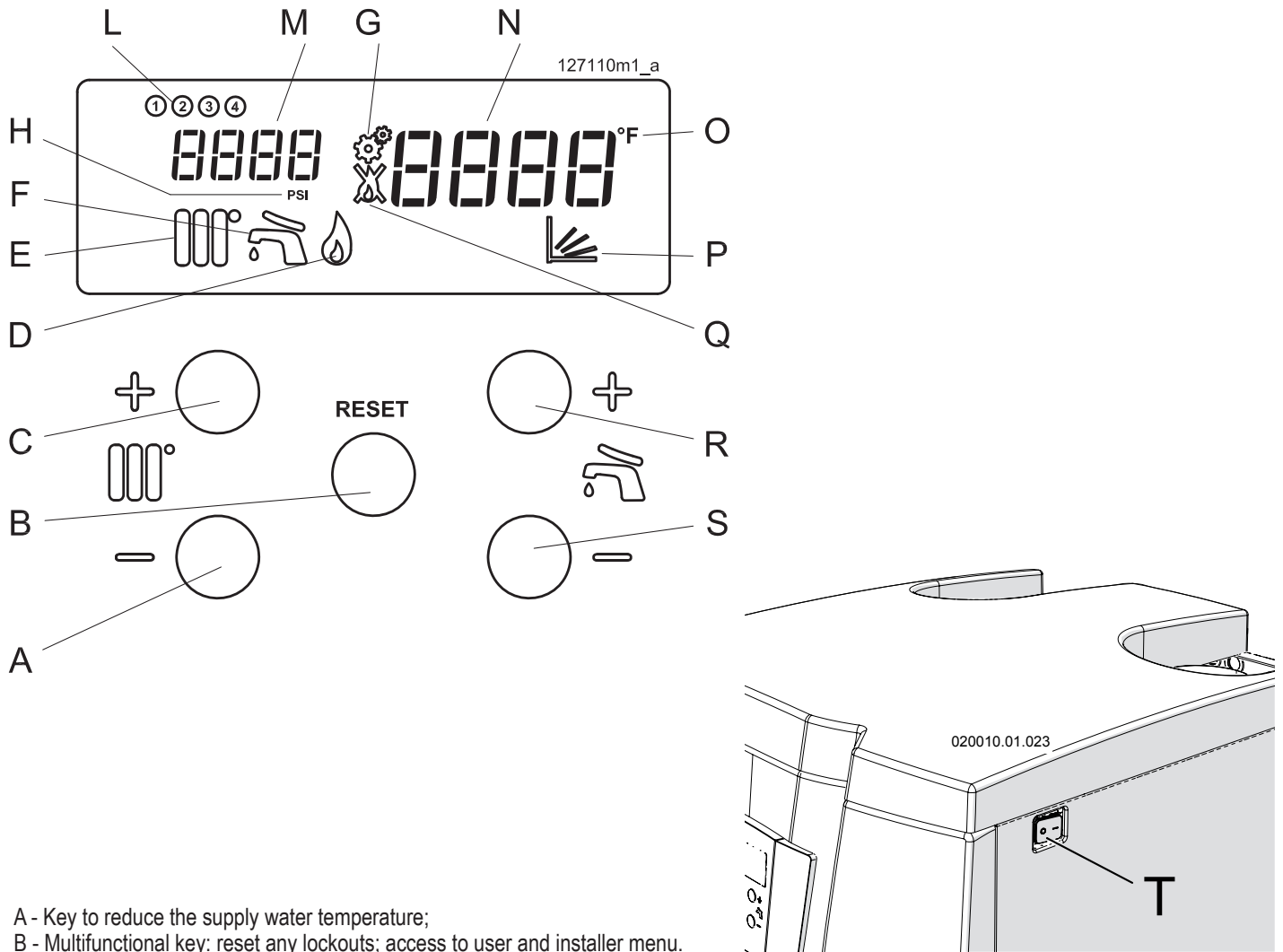

- A - Key to reduce the supply water temperature;
- B - Multifunctional key: reset any lockouts; access to user and installer menu.
- C - Key to increase the supply water temperature;
- D - Flame icon, is present when the flame is present;
- E - Radiator icon. Present when heater is enabled to work. Blinking when heater working;
- F - Faucet icon. Present when an indirect water heater (coil water heater) is enabled. Blinking when an indirect water heater (coil water heater) is loading;
- H - Unit of measure of the water system pressure
- L - Burner unit indicators: Light when burner is burning; blinking when burner is in lockout or in blocking error
 - ① = Burner 1 (master)
 - ② = Burner 2
 - ③ = Burner 3
 - ④ = Burner 4
- M - Water pressure gauge and indicator of the parameters
- G - Icon indicating access to the installer menu
- N - Supply water temperature gauge and indicator of the parameters value
- O - Unit of measure of the temperature
- P - Icon displayed when the outdoor sensor is active
- Q - Flame crossed icon: is present when the appliance is in lockout or blocking error condition
- R - Multifunctional key: increase the indirect water heater (coil water heater) temperature; scroll the parameters; increase the parameters' value;
- S - Multifunctional key: decrease the indirect water heater (coil water heater) temperature; scroll the parameters; decrease the parameters' value;
- T - On-Off Main power switch

Figure 16-1 Instrument panel and main power switch

16 - USE

16.1 - Check water pressure

16.1.1 - Check water pressure on IB boiler

If the pressure inside the water circuit falls below the minimum pressure for the system, the appliance switches off and the display "N" as per Figure 16-1, shows Err 59 to indicate that it is necessary to restore the correct pressure. Open the filling valve and check the pressure on the pressure gauge "M" of Figure 16-1, the word Err 59 will disappear when the pressure back at the right value. To prevent accidental relief valve openings, fill the circuit slowly.

CAUTION!!! During normal operations, the filling valve must always remain in the closed position.

If, with time, the pressure drops, restore the correct value. This operation may have to be repeated several times during the first month of operations to remove any air bubbles present.

If after one month the pressure continue to decrease, call a qualified service technician.

CAUTION!!! Continual fresh make-up water will reduce boiler life. Mineral buildup in the heat exchanger reduces heat transfer, overheats the stainless steel heat exchanger, and causes failure. Addition of oxygen carried in by makeup water can cause internal corrosion in system components. Leaks in boiler or piping must be repaired at once to prevent makeup water entering the boiler.

16.1.2 - Check water pressure on IW water heater

If the pressure inside the water circuit falls below the minimum pressure for the system, the appliance switches off and the display "N" as per Figure 16-1, shows Err 59 to indicate that it is necessary to restore the correct

pressure. Because water heater is installed in an open loop system, you have to check for the net water pressure or for any pressure reducer upstream of the water supply circuit. When the pressure is restored the Err 59 will disappear.

16.2 - Overview

The heater is pre-set with standard parameters. However, it is possible to make a number of changes or consult the parameters by means of using the "Users' Menu" (see Section 16.13) and the "Installers' Menu" (see Section 16.14).





During functioning display "N" of Figure 16-1, displays the supply temperature, and display "M" (see Figure 16-1) shows the pressure of the water. The various operating statuses are shown with other icons as per Figure 16-1.

16.3 - Displays

During normal operations, the display will remain permanently off, except when the appliance goes into Lockout, or in Blocking error.

In any case, pressing any key, display will light on and will stay light on for 5 minutes from the last pressing key.

16.4 - Start-up procedure

1. Open the manual gas shutoff valve;
2. switch on electric power to the heater;
3. If the display shows code Err 65, it means that the polarity has not been observed (Call service department to restore the situation, do not attempt to repair it);
4. press key  or  to setup the supply temperature desired, then press RESET key to save the change.
5. press key  and  to setup the indirect water heater desired temperature, then press RESET key to save the change.

The flame control appliance will start-up the burner.

If the burner fails to ignite within 60 seconds, the heater will automatically attempt ignition another four times,

after which if it fails to start-up, it will shut down and the display will show

Loc 1 together icon .



When multi-burner unit models 399 - 1000 go into any Lockout or Blocking error the display will show the icon  and the corresponding burner icon in fail (① ② ③ or ④) that blink.

Press the RESET key in order to re-set normal operating conditions. On units model 399 up to 1000, to restore the normal operating condition, press RESET key one time, display will show the type of lockout, than press RESET key again (to back in normal display mode, press and hold for at least 5 seconds RESET key).

The heater will automatically attempt another start-up.

CAUTION!!! If the appliance frequently shuts down, contact a qualified technician to restore normal running conditions. Do not attempt to repair it.

16.5 - IW supply water temperature adjustment

The water heater provides hot water at the temperature set by adjusting keys  or  as shown in Figure 16-1.



When the keys are pressed, the display, item "N" in Figure 16-1, shows the supply water setpoint being selected. The range within which the water can be set is 68°F (20°C) to 176°F (80°C).

WARNING!!! Water temperature over 125°F can cause severe burns instantly or death from scalds. Children, disabled and elderly are at highest risk of being scalded. Feel water before bathing or showering.

16 - USE

16.6 - IB - Indirect water heater temperature adjustment

If the heater is installed to perform double service (heating and domestic hot water by an indirect water heater), to control the indirect water heater temperature you have to use keys

 and . When the keys are pressed, the display, item "N" in Figure 16-1, shows the indirect water heater setpoint being selected. The range within which the indirect water heater can be set is 104°F (40°C) to 140°F (60°C).





WARNING!!!

Water temperature over 125°F can cause severe burns instantly or death from scalds. Children, disabled and elderly are at highest risk of being scalded. Feel water before bathing or showering.

16.7 - IB - Heating temperature adjustment

The boiler supplies hot water at the temperature set by adjusting keys

 or  as shown in Figure 16-1. The room thermostat turns the circulator pumps on in order to satisfy the heat demand of the rooms controlled by the thermostat. To maximize the heaters' performance, the heating temperature, should be set at a value that is just sufficient to maintain the desired temperature of the rooms. As the weather gets colder, progressively increase the heating water temperature by key . When the weather gets milder turn the water temperature down.

16.8 - IB - Outdoor reset adjustment

While in the "Installers' Menu" (Section 16.14), set the 2003 parameter to 01. In this mode the heating supply temperature, calculated temperature in Figure 16-2, will be adjusted automatically based on the input from the outdoor temperature sensor. The relationship between the outdoor temperature and the supply water temperature, corresponds with the graphs shown in Figure 16-2. In order to change the relationship between the supply water temperature and the outdoor temperature, all parameters listed in section 16.8.2 must be set.

16.8.1 - Outdoor reset applications

Outdoor reset is a sophisticated way to maximize comfort and boiler efficiency. When making adjustments to change the supply temperature, it is advisable to first set the suggested default values for the desired curve shown in Figure 16-2. If these default values do not produce a satisfactory result, then proceed to make the appropriate adjustments bearing in mind that:

- A - each parameter must be changed very gradually;
- B - after each parameter change, wait at least 24 hours in order to see the result;
- C - the closer the adjustment curve matches the actual load of the building, the greater the comfort and the energy savings will be;

16.8.2 - Outdoor reset: setting parameters

Refer to Section 16.14 and set:

- 2020 = "Warm weather shutdown temperature". When the outdoor temperature decrease below this value the heating system is forced to shut down. Suggested starting value is 72°F (22°C).
- 2021 = "Winter outdoor temperature". Is the design winter temperature used for the basic heat load calculation.

- 2022 = "Winter supply temperature". Is the supply temperature correspondent to the "Winter outdoor temperature" (parameter 2021). Suggested values are 104°F (40°C) for floor radiant panels or 158°F (70°C) for radiators heating systems.
- 2023 = "Spring outdoor temperature". Is the typical spring outdoor temperature you want the heating service to the minimum capacity. Suggested value is 64°F (18°C).
- 2024 = "Spring supply temperature". Is the supply temperature correspondent to the "Spring outdoor temperature" (parameter 2023). Suggested values are 86°F (30°C) for floor radiant panels or 108°F (42°C) for radiators heating systems.

Once selected, reset adjustment is completely automatic; when the outdoor temperature is higher than parameter 2020 ("Warm weather shutdown temperature") the heating service switches off. When the outdoor temperature reduce below parameter 2020 ("Warm weather shutdown temperature"), the heating service switches back on. If, for some reason the heating service doesn't match the load, using parameters 2022 (during cold winter) and 2024 (during spring season), to rise or lower the calculated temperature and match the desired room temperature.

16 - USE

105722m0_b

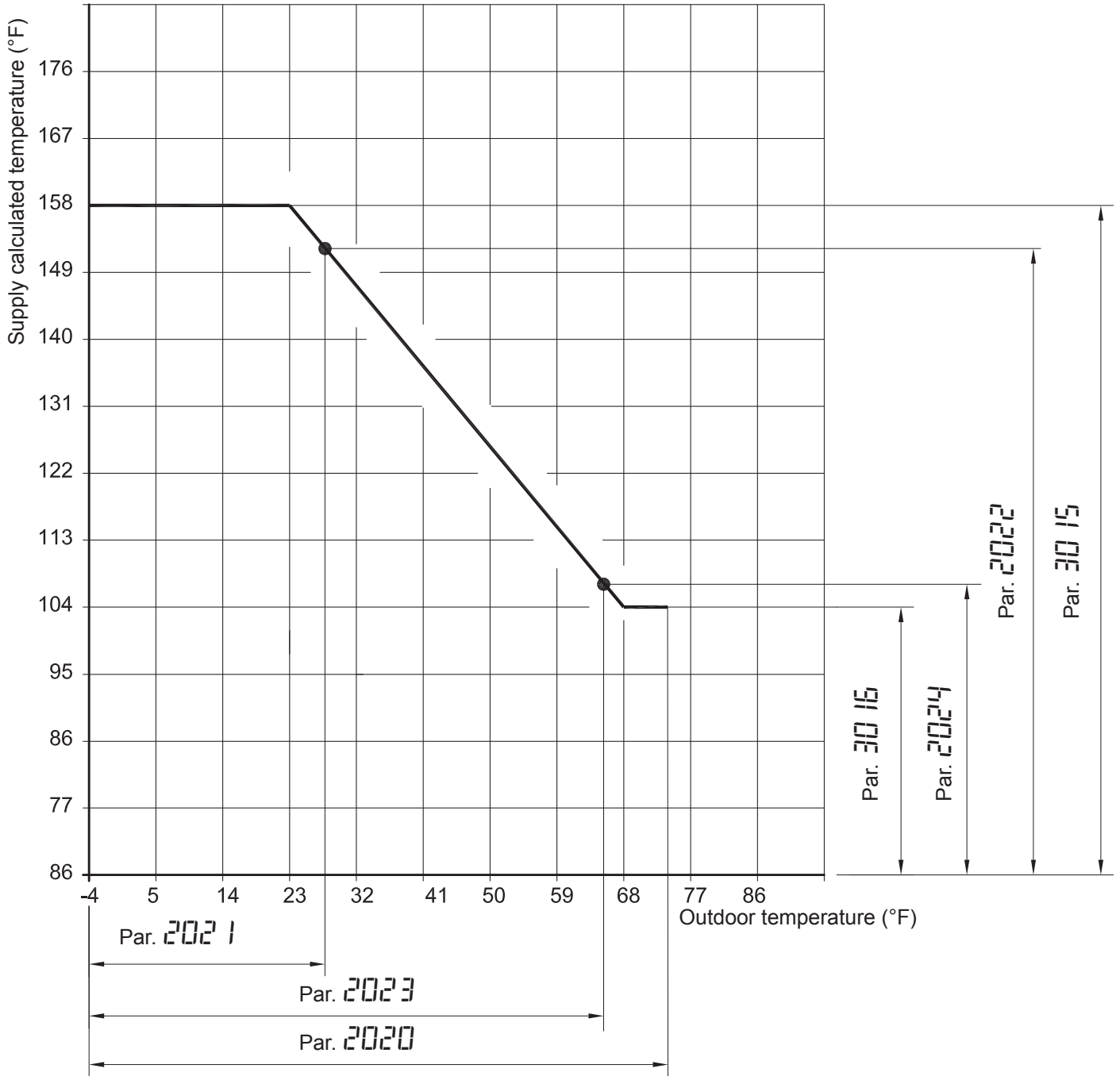

- Par. 30 15 = Maximum supply temperature
- Par. 30 16 = Minimum supply temperature
- Par. 2020 = Warm weather shutdown temperature
- Par. 202 1 = Winter outdoor temperature
- Par. 2022 = Winter supply temperature
- Par. 2023 = Spring outdoor temperature
- Par. 2024 = Spring supply temperature

Figure 16-2 - Graph of the outdoor reset settings

16.9 - Delays, alarms and protective actions

To protect the life of the appliance, improve comfort, and maximize energy savings, the following timings have been incorporated into the control logic:

- a - Pump delay: each time the room thermostat is satisfied, the circulator pump continues to run for 4 minutes;
- b - DHW delay: each time the domestic hot water demand is satisfied, a 4 minute delay pass before the end of the service (if a need for heating is present the 4 minute delay is bypassed);
- c - Time delay in restarting the burner: in its normal functioning state, every time the burner stops, there is a delay time of 3 minutes before the burner starts again.

16.10 - Circulator pump protection

During stand by state, circulator pumps run once a day for around 15 seconds to prevent them from seizing.

16.11 - Heater's Freeze protection

CAUTION!!! For the freeze protection function to work, the heater must remain connected to the electrical and gas supplies with DHW and heating service switched to OFF

CAUTION!!! This freeze protection function is conceived to protect the heater only, not the system.

Once the heater has reached a temperature of 50 °F (10 °C), the local pump will automatically come on. If the temperature falls below 41 °F (5 °C), the burner will light to prevent the heater from freezing.

If the heater will not be used for long time it should be drained per Section 17.9.



16.12 - Display in energy saver mode

The display, in Figure 16-1, is switched off each time no key is touched for at least 5 minutes, with the exception of when it displays errors or settings. If you want to leave the display continuously ON, set parameter 2100 to 0 (zero) (see Section 16.14).

16 - USE

16.13 - “Users’ menu”

Pressing RESET key for 2 seconds, you will enter the “Users’ menu”. When entering the “Users’ menu”, the display, item “M” in Figure 16-1, will

start showing parameters from 1000. Press keys  and  to scroll all parameters inside this menu. All parameters into this “Users’ menu” are reading only. For unit models 399 up to 1000, parameters addressed to “Burner

1 (Master)” are applicable for that burner only. If you want to see the same parameters for other burners you have to connect the display to the burner you want to see. To do this follow procedure in Section 17.7.

Parameter	Parameter’s description	Units
1001	Burner 1 supply temperature	°F
1002	Indirect water heater temperature	°F
1004	Outdoor sensor temperature	°F
1006	Burner 1 Flue gas temperature	°F
1007	Burner 1 Return temperature	°F
1008	Burner 1 Ionisation current	µA (micro ampere)
1009	State of the Local pump (and of the Burner 1 Motorized valve)	ON/OFF
1010	State of the CH pump	ON/OFF
1011	State of the DHW pump	ON/OFF
1012	Calculated CH setpoint (when outdoor sensor or 0-10Vdc input is enabled) (only for 199 model; for 399, 500, 750 and 1000 models see Parameter 1107)	°F
1040	Burner 1 Actual Fan speed	rpm/min
1041	Burner 1 Ignition fan speed	rpm/min
1042	Burner 1 Low power fan speed	rpm/min
1043	Burner 1 High power fan speed	rpm/min
1051	Burner 1 Last lockout number	\
1052	Burner 1 Last Blocking error	\
1053	Burner 1 Number of flame failures	no
1055	Burner 1 Number of failed ignitions	no
1056	Burner 1 Total hours of operation	Hr x 10
1057	Burner 1 Total hours of operation of the indirect water heater	Hr x 10
1059	**Burner 1 Interval between Lockouts. May be: 1:MIN; 2:HRS; 3:DAY; 4:WK	
1060	**Burner 1 Interval between Blocking errors. May be: 1:MIN; 2:HRS; 3:DAY; 4:WK	
1062	Burner 1 Water flow	GPM
1101	MULTIBURNER: number of burners ON	n
1102	MULTIBURNER: header temperature	°F
1103	MULTIBURNER: any Burner into Lockout	/
1104	MULTIBURNER: any Burner into Blocking Error	/
1106	MULTIBURNER: system is in emergency mode	/
1107	MULTIBURNER: current multiburner setpoint	°F
1120	MULTIBURNER: burner 1 modulating level	%
1121	MULTIBURNER: burner 2 modulating level	%
1122	MULTIBURNER: burner 3 modulating level	%
1123	MULTIBURNER: burner 4 modulating level	%

** How to read the timer values:

- Eg: If it shows 1:29, it means 29 minutes;
- Eg: If it shows 2:12, it means 12 hours;
- Eg: If it shows 3:15, it means 15 days;
- Eg: If it shows 4:26, it means 26 weeks;

16 - USE

16.14 - “Installer’s menu”

CAUTION!!!







Changing these parameters could cause the heater and therefore the system to malfunction. For this reason, only a qualified technician who has in-depth knowledge of the heater should change them.

The heater’s micro-processor makes this menu of parameters available to the qualified technician for diagnostic and adjustment of the appliance to the system.

When entering the “Installers’ Menu”, the display in Figure 16-1, will start to

show the icon  and parameters over 2000 indicating that a change of mode has taken place.

To access the “Installers’ Menu” (see also Section 20 to better understand the several menus) proceed as follows:

1. press and hold together buttons RESET and  for 5 seconds until the  icon is displayed;
2. release the two precedent buttons;
3. press and release the  and  buttons to scroll through the list of the parameters;
4. once the parameter has been displayed, it can be changed pressing the RESET button (value start to blinking) and using the  and  keys you can change the value;
5. press and release the RESET button to confirm the amended data before moving to the next parameter.

6. To exit the “installers’ Menu”, press and hold RESET button for more than 5 seconds until the  icon stops to be displayed.

NOTICE! If no key is pressed for more than 60 seconds, the control automatically exits the “Installers’ menu”. Any parameter change not saved using the RESET button, will be lost.

For heaters models 399 up to 1000 parameters addressed to “Burner 1” are applicable for that burner only. If you want to see the same parameters for the other burners you have to connect the display to the burner you want to see. To do this follow procedure in Section 17.7. The next table lists each parameter, what it affects and its adjustment range. Custom value column is at your convenience to record changed values in the event you need to change the control board.



Parameter	Parameter’s description	M.U.	Range	Boilers’ factory settings	W.Heat. factory settings	Custom. value
2001	Burner 1 minimum Power	%	1 to 50	1	1	
2002	Burner 1 maximum Power	%	1 to 100	100	100	
2003	CH mode	nn	0: CH with thermostat; 1: CH with outdoor reset; RT opening will stops heating; 2: CH with outdoor reset; RT closure will reduce setpoint of par 2027; 3: CH with permanent heat demand; RT closure will reduce setpoint of par 2027 4: CH with 0-10Vcc input; 5: N/A	0	0	
2004	Burner 1 Wait time after max differential	sec	10 to 30	30	30	
2005	Post CH pump time	sec	10 to 260	240	240	
2010	System test: For model 199	\	Off, Low, Ign, High (Set back parameter to OFF to exit from this state)	OFF	OFF	
2011	System test: Local pump (and of the Burner 1 Motorized valve)	\	On or OFF	OFF	OFF	
2012	System test: CH pump	\	On or OFF	OFF	OFF	
2013	System test: DHW pump	\	On or OFF	OFF	OFF	
2014	Display test (when RESET button is pushed all display icons will light-on. Next RESET buttons back in settings menu)	\	\	\	\	
2020	Warm weather shutdown temperature	°F	32 to 95	69	N/A	
2021	Reset curve design: winter outdoor temperature	°F	-4 to 41	24	N/A	
2022	Reset curve design: winter supply temperature	°F	32 to 176	176	N/A	
2023	Reset curve design: spring outdoor temperature	°F	32 to 86	69	N/A	

16 - USE

2024	Reset curve design: spring supply temperature	°F	32 to 104	104	N/A	
2027	Night setback temperature	°F	2 to 90	18	N/A	
2040	N/A					
2041	N/A					
2042	Burner 1 anti cycling: time	sec	10 to 900	180	180	
2043	Burner 1 anti cycling: differential temperature	°F	0 to 36	28	28	
2062	DHW post pump time	sec	10 to 255	240	N/A	
2063	DHW max priority time	min	1 to 60	30	N/A	
2067	DHW priority		0 = (TIME), DHW has priority to CH during DHW max priority time (2063) 1 = (OFF), CH always has priority to DHW. 2 = (ON), DHW always has priority to CH	2	N/A	
2100	Display: delay to shut off	min	0 to 30	5	5	
2101	MULTIBURNER Emergency mode (If sensor 1102 fail)	\	no or yES	Yes	Yes	
2102	MULTIBURNER Emergency setpoint	°F	68 to 149	113	113	
2103	MULTIBURNER start delay time	sec	1 to 900	180	15	
2104	MULTIBURNER stop delay time	sec	1 to 900	180	15	
2105	MULTIBURNER start burner diff.	°F	0 to 36	9	9	
2106	MULTIBURNER stop burner diff.	°F	0 to 36	9	9	
2107	MULTIBURNER calculated setpoint. Max offset up.	°F	1 to 36	18	9	
2108	MULTIBURNER calculated setpoint. Max offset down.	°F	1 to 36	36	9	
2109	MULTIBURNER next burner start rate	%	1 to 100	70	70	
2110	MULTIBURNER next burner stop rate	%	1 to 100	10	10	
2111	MULTIBURNER rotation interval	Days	0 to 9	6	6	
2113	MULTIBURNER start modulation delay factor	min	0 to 60	5	0	
2114	Burner 1 post local pump time	sec	0 to 255	240	240	
2200	System test: all burners together.	\	Off, Low, Ign, High	OFF	OFF	
2201	System test: Burner 1 (Master).	\	Off, Low, Ign, High	OFF	OFF	
2202	System test: Burner 2.	\	Off, Low, Ign, High	OFF	OFF	
2203	System test: Burner 3.	\	Off, Low, Ign, High	OFF	OFF	
2204	System test: Burner 4.	\	Off, Low, Ign, High	OFF	OFF	

16.15 - Diagnostic



During normal operation display can show the information below:

Parameter	Parameter description	Visualization on display "N" (see Figure 16-1)
	Heater is doing antifreezing protection	Supply temperature (°F)
	Light fixed = Indirect water heater enabled Blinking = indirect water heater loading	Supply temperature (°F)
	Light fixed = Hot water supply enabled Blinking = Hot water supply active	Supply temperature (°F)

16.16 - Diagnostic: Lockouts “Loc”

To RESET a lockout on units model 199, simply press RESET key. On multi-burner unit models 399 up to 1000, when the heater goes into lockout state you'll see  icon and the corresponding burner icon

(① ② ③ or ④) if failing, will blink. To reset the lockout press the RESET key, the display will show the Lockout number, you can try to reset the lockout by pushing the RESET key again. Press and hold the RESET key for 5 seconds to go back into normal display condition.

Loc	Description	Checks	Solutions
Loc 1	No flame detected after five ignition attempts.	a-correct gas supply pressure (see section 15.7); b-ignition spark (see section 17.4); c-correct amount of gas (see sections 15.7 and 15.8); d-120Vac at the gas valve; e-resistance of the two gas valve coils should be 0.18 kohm and 1.1 kohm; f- If the burner lights, but goes out at the end of the ignition attempt, check: that the ionization current is set at a value greater than 4uA (follow procedure in section 17.1.10)	a-If the gas supply pressure is incorrect, it must be adjusted to the correct pressure; b-If spark is not present, check for correct ignition electrode position and gap as per section 17.4; If position is correct, check for 120Vac at the supply of the spark generator. c-inspect the vent system and eliminate any obstructions; d-if the voltage to the gas valve is not 120Vac the power control board must be replaced; e-if the resistance of the gas valve coils is not 0.18 kohm and/or 1.10 kohm, the gas valve must be replaced. f-If the ionization current is not greater than 4uA, confirm that the CO2 content is adjusted properly (see section 15.8). Check the flame detection electrode (section 17.4) and if necessary replace it, check the integrity of the flame detection electrode electrical wires.
Loc 2	Gas valve not supplied before try to ignition (When this error happens to burner 1 (MASTER) stops all other burners)	a - Check High limit temperature switch b - Check High limit flue temperature fuse	 WARNING!!! If the high limit temperature fuse melt, before any replacement, it is mandatory to contact the appliance manufacturer to prevent any permanent damages to the heat exchanger. Failure to comply with this requirement can result in excessive levels of carbon monoxide which can result in severe personal injury or death!
Loc 3	Gas valve lost cable connection during fire	a - Check the integrity of the wires connections between gas valve and control board	a - If wires are interrupted, replace the wires b - If wires are ok try to replace the gas valve or the power control board
Loc 4	Gas valve relay not closing	a - Check the integrity of the wires connections between gas valve and control board	a - If wires are interrupted, replace the wires b - If wires are ok try to replace the gas valve or the power control board
Loc 5	Gas valve circuit (When this error happens to burner 1 (MASTER) stops all other burners)	a - Check High limit temperature switch b - Check High limit flue temperature fuse	 WARNING!!! If the high limit temperature fuse melt, before any replacement, it is mandatory to contact the appliance manufacturer to prevent any permanent damages to the heat exchanger. Failure to comply with this requirement can result in excessive levels of carbon monoxide which can result in severe personal injury or death!
Loc 6	Safety relay open error		Replace the power control board
Loc 7	Safety relay closed error		Replace the power control board
Loc 11	Blocking error over 20 hr	Press RESET button to see the Blocking error reference and proceed follow it	
Loc 12	Fan error	a - Check for 120Vac power connection of the fan b - Check PWM connection of the fan	a - If no 120Vac is present replace the power control board b - If no PWM signal, replace power control board c - Try to replace the fan
Loc 13	Internal software error		Replace the power control board
Loc 14	Internal software error		Replace the power control board
Loc 15	Internal software error		Replace the power control board
Loc 16	Internal software error		Replace the power control board
Loc 17	Internal software error		Replace the power control board
Loc 18	Internal software error		Replace the power control board

16 - USE

Loc 19	Internal software error		Replace the power control board
Loc 20	Flame lost three times	Control: that the ionisation current is at a value over 60 (see parameter 1008) Control: that the fumes exhaust must be protected with a wind-proof grid	If the ionisation current is not over 60, the CO2 must be checked (see chapter 15.8) and restore the correct value. Check the ionisation electrode and replace it if necessary. Check the integrity of the ionisation current electric circuit cables. If the fumes exhaust is placed in a vertical wall it must be protected with a wind-proof grid. If the fumes exhaust is positioned on the roof, make sure that it is not in an area of reflux and that any windproof chimney pot is really efficient.
Loc 21	Internal software error		Replace the power control board
Loc 22	Internal software error		Replace the power control board
Loc 23	Internal software error		Replace the power control board
Loc 24	Internal software error		Replace the power control board
Loc 25	Gas valve circuit (When this error happens to burner 1 (MASTER) stops all other burners)	a - Check High limit temperature switch b - Check High limit flue temperature fuse	 WARNING!!! If the high limit temperature fuse melt, before any replacement, it is mandatory to contact the appliance manufacturer to prevent any permanent damages to the heat exchanger. Failure to comply with this requirement can result in excessive levels of carbon monoxide which can result in severe personal injury or death!
Loc 26	Internal software error		Replace the power control board
Loc 27	Flame present with closed gas valve		Replace the gas valve
Loc 28	Flame present with closed gas valve		Replace the gas valve
Loc 29	Interlock input (When this error happens to burner 1 (MASTER) stops all other burners)	a - Check LWCO connection b - Check flue blocked pressure switch	a - If LWCO intervenes, try to reset it b - Check if flue gas line is free from any blockage
Loc 30	Internal software error		Replace the power control board
Loc 31	Five times flame lost during one demand	a) Check detection electrode; b) Check for any obstruction on air inlet / flue exhaust system c) Check for any air inlet contamination from combustion gas (Eg. flue exhaust terminal too much near air inlet terminal)	a) Try to replace detection electrode b) Remove any obstruction c) Remove the cause of the air inlet contamination
Loc 32	Internal software error		Replace the power control board
Loc 33	Internal software error		Replace the power control board
Loc 34	Internal software error		Replace the power control board
Loc 35	Internal software error		Replace the power control board
Loc 36	Internal software error		Replace the power control board
Loc 37	Internal software error		Replace the power control board
Loc 38	flue gas sensor does not increase	a - Check flue gas sensor match section 17.10 b - Check if flue gas sensor (parameter 1006) increases its temperature when burner is on	a - If it does not match, it must be replaced b - If temperature does not increase, replace the flue gas sensor or the control board

16.17 - Diagnostic: Blocking errors “Err”

Blocking errors are generated by a permanent fault. There is no way to unlock the unit other than to resolve the cause of the fault.

On multi-burner unit models 399 up to 1000, when the burner goes into a

blocking error state, you'll see  icon

and the corresponding burner icon

(① ② ③ or ④) if failing will blink. To see the blocking error code, press the RESET key and display will show the blocking error code. Press and hold the RESET key to go back into normal display condition.

Err	Description	Checks	Solutions
Err 0	Self checking	Not needed	During start up, display shows “Err 0” temporarily because it is doing its self checking
Err 45	Internal software error		Replace the power control board
Err 46	Internal software error		Replace the power control board
Err 47	Internal software error		Replace the power control board
Err 48	Internal software error		Replace the power control board
Err 49	Internal software error		Replace the power control board
Err 50	Internal hardware error		Replace the power control board
Err 51	Internal hardware error		Replace the power control board
Err 52	Internal hardware error		Replace the power control board
Err 53	Internal hardware error		Replace the power control board
Err 54	Flame is detected in a state in which no flame is allowed to be seen.		Replace the power control board
Err 55	Low water pressure error	Check pressure sensor	Replace the pressure sensor
Err 56	Low water pressure error	Check pressure sensor	Replace the pressure sensor
Err 57	Low water pressure error	Check pressure sensor	Replace the pressure sensor
Err 58	Low water pressure error	Check pressure sensor	Replace the pressure sensor
Err 59	Low water pressure error (This error stops all modules)	a - Check the pressure into the water system and eventually increase it	a - If water system pressure is over parameter 3022, replace the water pressure sensor
Err 60	High flue gas temperature error	a - Check if return temperature is higher than 145°F (62°C) at high fire (see also section 4.1); b - Check the combustion efficiency of the burner in fail. Combustion Efficiency must be higher than 88%; c - Check the flue gas temperature sensor match section 17.10.	a - If return temperature is higher than 145°F (62°C) downrate the capacity or reduce the water flow; b - If combustion efficiency is lower than 88%, try to clean the flue gas side and the water side of the heat exchanger; c - If flue temperature sensor do not match section 17.10, it must be replaced.
Err 61	Return temperature is higher than 176°F (80°C)	a - Check if temperature sensor match section 17.10 b - Check if supply and return pipe are reversed	If temperature sensor do not match section 17.10, it must be replaced.
Err 62	Block drain switch is active (This error stops all modules)	a - Check if the condensate drain is blocked b - Check if the condensate box is blocked	a - Remove any obstruction from the condensate drain b - check the condensate box, if medium is exhaust it must be replaced
Err 64	No correct Frequency signal or no correct ground connection or no communication with the WD	a - Check the frequency signal. It must be between 55 and 65Hz b - Check the ground connection (between ground and neutral it must be 0 volt)	a - If out of range, ask your electrical supplier. b - If the ground connection is not right ask to your electrical supplier Diversely try to replace the power contro board
Err 65	Hot neutral reversed	Check supply voltage polarity	Reverse supply voltage polarity, if it's the case
Err 66	Net freq. error detected in the main	Check the frequency signal. It must be between 55 and 65Hz	If out from range, ask your electrical supplier. Diversely try to replace the power contro board
Err 67	Faulty earth connection	Check the earth connection to the appliance	Repristinate the earth connection
Err 68	Watchdog communication error		Replace the power control board
Err 72	Supply sensor open	Check if temperature sensor match section 17.10	If temperature sensor do not match section 17.10, it must be replaced.
Err 73	Return sensor open	Check if temperature sensor match section 17.10	If temperature sensor do not match section 17.10, it must be replaced.
Err 76	DHW sensor open	Check if temperature sensor match section 17.10	If temperature sensor do not match section 17.10, it must be replaced.
Err 80	Supply sensor shorted	Check if temperature sensor match section 17.10	If temperature sensor do not match section 17.10, it must be replaced.
Err 81	Return sensor shorted	Check if temperature sensor match section 17.10	If temperature sensor do not match section 17.10, it must be replaced.
Err 84	DHW sensor shorted	Check if temperature sensor match section 17.10	If temperature sensor do not match section 17.10, it must be replaced.
Err 86	Flue sensor shorted	Check if temperature sensor match section 17.10	If temperature sensor do not match section 17.10, it must be replaced.

16 - USE

Err 87	Reset button error	Too many reset button pushing in 60 sec	
Err 93	Appliance selection error	Check the list of 3000 parameters (Section 21)	
Err 107	Internal software error		Replace the power control board
Err 108	Internal software error		Replace the power control board
Err 109	Error happening to burners 2, 3 or 4	When burner 1 (MASTER) goes in a general error, will stops burners 2, 3 and 4 generating an "Err 109"	Resolve the error to the burner 1 (MASTER)
Err 110	Flapper valve not open error	a) Check for any obstruction into the exhaust system b) Check if the fan is running c) Check the flapper valve and its control sensor (See Figure 3-2 items 32 and 33)	a) Remove the obstruction from flue exhaust b) Replace the fan or the power control board c) Replace the flapper valve or its control sensor (See Figure 3-2 items 32 and 33)
Err 111	Flapper valve not closed error	Check the flapper valve and its control sensor (See Figure 3-2 items 32 and 33)	Replace the flapper valve or its control sensor (See Figure 3-2 items 32 and 33)
Err 112	Internal software error		Replace the power control board
Err 113	Internal software error		Replace the power control board
Err 114	Too low water flow	a - Check water flow into the system (parameter 1062), it must be higher than parameter 3035.	a - Increase the water flow into the system b - Check for any obstruction into the water system
Err 115	Multiple burner master failure		Reset via 3013 parameter
Err 116	Multiple burner communication failure (This error will stops all modules)	a - Bus communication interrupted b - Burner is not working	a - Check for the bus communication b - Repristiniate the burner that is light off.
No Conn	Microprocessor in lockout	a - Check wires of the water pressure sensor are not in short circuit b - Check wires of the water flow sensor are not in short circuit c - Check display wires are connected to the burner 1 (MASTER)	a - If wires are not in short circuit, replace the pressure sensor b - If wires are not in short circuit, replace the water flow sensor c - If display wires are connected to burner 2, 3 or 4 and the relative board is off, display shows "No Conn"

16.18 - Flue blocked pressure switch

This appliance is equipped with a safety flue blocked pressure switch (see Figures 3-3 through 3-9, item "24") that shut-off the unit when the flue exhaust vent pipe is blocked. If this pressure switch shuts off the unit (Loc 2, Loc 5 or Loc 25), do not attempt to place the heater in operation but contact a qualified service agency that will reset the unit after checking for any potential dangerous situation.

! WARNING!!! If the safety flue blocked pressure switch shuts off the system do not attempt to reset or repair the unit. It is mandatory to contact a Qualified service agency. Failure to comply with this requirement can result in excessive levels of carbon monoxide which can cause severe personal injury or death!

16.19 - Shuts heater down

1. Follow "To Turn Off Gas to Appliance" on page 3 of this manual.
2. Do not drain the system unless exposure to freezing temperatures will occur.
3. Do not drain the system if it is filled with an antifreeze solution.

16.20 - How to clean the appliance jacket

To clean the appliance jacket, use only a soft cloth dampened with water. Do not use aggressive or abrasive agents.

17 - MAINTENANCE

17.1 - Care and maintenance

This section must be brought to the attention of the user by the installer so that the user can make the necessary arrangements with a qualified service agency for the periodic care and maintenance of the heater. User must check its heater follow Figure 17-1 column "User maintenance".

The installer must also inform the user that the lack of proper care and maintenance of this heater and any fuel burning equipment may result in an hazardous condition.

Installer should discuss contents of Section 16 (User's section) with the user.

A trained and qualified service technician should perform the inspection listed in these instructions before each heating season and at regular intervals.

! WARNING!!! Servicing, inspection and adjustment must be done by a trained technician in accordance with all applicable local and national codes. Improper servicing or adjustment could damage the heater! Failure to comply with this warning can result in a fire or explosion causing property damage, personal injury or loss of life!

Service and maintenance schedules	
Service Technician	User maintenance
<p>Annual Startup:</p> <ul style="list-style-type: none"> - Address reported problems (Follow Section 17.1.1); - Check all piping for gas leaks (Follow Section 17.1.2) - Verify flue and air lines in good condition and sealed tight (Follow Section 17.1.3); - Check system water pressure/system piping/expansion tank (Follow Section 17.1.4); - Check control settings (Follow Section 17.1.5); - Check ignition and flame sense electrodes (Follow Section 17.1.6); - Check wiring and connections (Follow Section 17.1.7); - Perform start up checkout and performance verification (Follow Section 17.1.8); - Flame inspection (Follow Section 17.1.9); - Check flame signal (Follow Section 17.1.10); - Inspect combustion chamber. Clean and vacuum if ther's presence of debris and/or products of the combustion (Follow Section 17.3). - Inspect thermal insulations inside the combustion chamber and replace them if they are cracked or damaged (Follow Section 17.3.1) - Clean condensate box and fill with fresh water (Follow Section 17.6). - Clean air filter (Follow Section 17.5) - Check the capacity input (Follow Section 15.9). - Check relief valve (Follow Section 17.1.11); 	<p>Daily:</p> <ul style="list-style-type: none"> - Check heater area (Follow Section 17.1.12); - Check pressure gauge (Follow Section 17.1.13); <p>Monthly:</p> <ul style="list-style-type: none"> - Check vent piping and vent termination screen (Follow Section 17.1.14); - Check air piping and air termination screen (Follow Section 17.1.15); - Check condensate drain system (Follow Section 17.1.16); - Check any air vents on the system that no leaks are present <p>Periodically:</p> <ul style="list-style-type: none"> - Test low water cut-off (if used) (Follow Section 17.1.19); - Reset low water cut-off button (if used) (Follow Section 17.1.20) <p>Every six month:</p> <ul style="list-style-type: none"> - Check heater piping (gas and water) for leaks (Follow Section 17.1.17); <p>End of season months:</p> <ul style="list-style-type: none"> - Shut heater down (unless heater used for domestic hot water) (Follow Section 17.1.18);

Figure 17-1 - Service and Maintenance Schedules

17 - MAINTENANCE

! WARNING!!! Never store combustible materials, gasoline or any product containing flammable vapors and liquids in the vicinity of the heater. Failure to comply with this warning can result in extensive property damage, severe personal injury or death!

! WARNING!!! Never obstruct the flow of combustion and ventilation air. Failure to provide adequate combustion air for this heater can result in excessive levels of carbon monoxide which can result in severe personal injury or death!

! WARNING!!! If maintenance is performed on the vent-air intake system it must be properly reassembled and sealed. Failure to properly maintain the vent-air system can result in excessive levels of carbon monoxide which can result in severe personal injury or death!

! WARNING!!! Before performing any maintenance operations, shut the heater off, close the manual gas shut-off valve (Figure 14-1) and shut electrical power off to the heater. Follow the Operating Instructions outlined in the section "SAFETY INSTRUCTIONS" (Page 3 of this manual).

17.1.1 - Address reported problems

Inspect any problems reported by the owner and correct before proceeding.

17.1.2 - Check all piping for gas leaks

1. Inspect all gas piping and verify to be leak free.
2. Check for gas leaks: using soap solution, check for gas leaks

from meter to appliance including all pipes and fittings and heater connection. Use liquid soap solution for all gas testing.

! WARNING!!! Do not check for gas leaks with an open flame. Use the bubble test. Failure to use the bubble test or check for gas leaks with an open flame can cause explosion, severe personal injury, death, or substantial property damage.

17.1.3 - Verify flue and air lines in good condition and sealed tight;

1. Check for obstruction, condensation, corrosion and physical damage, water stains, any signs of rust, other corrossions or separation of the vent and air intake piping.
2. Check outside terminations. Screens and louvers should be free of any debris and must be cleaned as required.

17.1.4 - Check system water pressure/system piping/expansion tank;

1. Check water piping and accessories for leaks. Slightest leaks should be corrected.
2. Check the system to be full of water and pressure to remain stable at correct setting on gauge.

CAUTION!!! Eliminate all system or heater leaks. Continual fresh makeup water will reduce heater life. Minerals can build up in sections, reducing heat transfer, overheating heat exchanger, and causing heat exchanger failure. Leaking water may also cause severe property damage.

17.1.5 - Check control settings

1. Set heaters setpoint low enough to end call for heat (see Sections 16.6 and 16.7. Gas valve should close

and burner should stop firing. Fan will go into a post purge, then shuts off.

2. Control Safety Shutdown test: with the burner firing, close the manual gas shut off valve (Figure 14-1). Gas valve should close and burner should stop firing. The boiler will try for ignition five times, then should lock out with a "Loc 1" error shown on the display. Open the manual gas shut-off valve, and verify your gas meter. Gas flow must be zero.

! WARNING!!! If gas flow occurs, close the manual gas shutoff valve and troubleshoot the system to determine why there is gas flow when the gas valve should be deenergized. Do not operate the boiler until the problem is resolved or a fire or explosion causing property damage, personal injury or loss of life may occur!

3. Press the "Reset" key to return to normal operation.

17.1.6 - Check ignition and flame sense electrodes

1. Remove the fan-burner assembly unit (see Section 17.3);
2. Remove any deposits accumulated on the ignition/flame sense electrode using sand paper;
3. Check electrodes positioning meet Section 17.4.

17.1.7 - Check wiring and connections

Inspect all heater wiring, making sure wires are in good condition and securely attached.

17.1.8 - Perform performance verification.

1. Run the unit at maximum input following Section 15.9. When in steady state, check the efficiency using as per recognized methods. Efficiency shall be not less than 88%.
2. Verify cold water pressure is correct and that operating pressure does not go too high (could be a problem on the expansion tank).

17 - MAINTENANCE

17.1.9 - Flame inspection

1. Inspect flame through sight glass.
2. If the flame is unsatisfactory at either high fire or low fire, clean the burner following Section 17.3.

17.1.10 - Check flame signal

1. Start unit and perform the procedure of Section 15.8 to check the flame signal.
2. At high fire and low fire the flame signal (parameter 1008) should be within values given in Section 18, header "ionisation current". A lower flame signal may indicate a fouled or damaged flame sense electrode. If cleaning the flame sense electrode does not improve, ground wiring is in good condition, and ground continuity is satisfactory, replace the flame sense electrode.

17.1.11 - Check relief valve

Inspect the relief valve and lift the lever to verify flow. Before operating any relief valve, ensure that it is piped with its discharge in a safe area to avoid severe scald potential. Read Section 7.2.2 and 8.2.2 before proceeding further. Relief valve should be re-inspected at least once every three years, by a licensed plumbing contractor or authorized inspection agency, to ensure that the product has not been affected by corrosive water conditions and to ensure that the valve and discharge line have not been altered or tampered with illegally. Certain naturally occurring conditions may corrode the valve or its components over time, rendering the valve inoperative. Such conditions are not detectable unless the valve and its components are physically removed and inspected. This inspection must only be conducted by a plumbing contractor or authorized inspection agency – not by the user.

! WARNING!!! Failure to re-inspect the relief valve as directed could result in unsafe pressure buildup, which can result in severe personal injury, death, or substantial property damage.

17.1.12 - Check heater area

! WARNING!!! To prevent potential of severe personal injury, death, or substantial property damage, eliminate all materials discussed below from the heater vicinity and the vicinity of the heater combustion air inlet.

If contaminants are found: Remove products immediately from the area. If they have been there for an extended period, call a qualified service technician to inspect the heater for possible damage from acid corrosion.

If products cannot be removed, immediately call a qualified service technician to re-pipe vent and air piping and locate vent termination/air intake away from contaminated areas.

1. Combustible/flammable materials -- Do not store combustible materials, gasoline or any other flammable vapors or liquids near the heater. Remove immediately if found.
2. Air contaminants -- Products containing chlorine or fluorine, if allowed to contaminate the heater intake air, will cause acidic condensate in the heater. This will cause significant damage to the heater if allowed to continue. Read the list of potential materials listed in Section 5.1.1. If any of these products are in the room from which the heater takes its combustion air, they must be removed immediately or the heater combustion air (and vent termination) must be relocated to another area.

17.1.13 - Check pressure gauge

1. Make sure the pressure reading on the heater pressure gauge (item "M" of Figure 16-1) does not exceed the maximum working pressure. Higher pressure may indicate a problem with the expansion tank.
2. Contact a qualified service technician if problem persists.

17.1.14 - Check vent piping

1. Visually inspect the vent outlet termination to be sure it is unobstructed. Visually inspect the entire length of the flue gas vent piping for any signs of blockage, leakage, or deterioration of the piping. Notify your qualified service technician at once if you find any problems.

! WARNING!!! Failure to inspect the vent system as noted above and have it repaired by a qualified service technician can result in vent system failure, causing severe personal injury or death.

17.1.15 - Check air piping

1. Visually inspect the air inlet termination to be sure it is unobstructed. Inspect the entire length of air piping to ensure piping is intact and all joints are properly sealed.
2. Call your qualified service technician if you notice any problems.

17.1.16 - Check condensate drain system

1. Inspect the condensate drain line, condensate fittings and condensate trap for signs of weeping or leakage.
2. If you detect signs of leakage, immediately contact your qualified service technician to inspect the heater and system.

17.1.17 - Check heater piping (gas and water)

1. If gas odor or leak is detected, immediately shut down the heater following the procedures on page 3. Call a qualified service technician.
2. Visually inspect for leaks around water piping. Also inspect the circulators, relief valve, and fittings. Immediately call a qualified service technician to repair any leaks.

! WARNING!!! Have leaks fixed at once by a qualified service technician. Failure to comply could result in severe personal injury, death, or substantial property damage.

17 - MAINTENANCE

17.1.18 - Shut heater down

1. Follow "To Turn Off Gas to Appliance" on page 3 of this manual.
2. Do not drain the system unless exposure to freezing temperatures will occur.
3. Do not drain the system if it is filled with an antifreeze solution.

17.1.19 - Test low water cutoff (if installed)

If the system is equipped with a low water cutoff, test the low water cutoff periodically, following the low water cutoff manufacturer's instructions.

17.1.20 - Reset button (low water cutoff)

Testing the low water cut-off shuts the unit off. Press the RESET button on the low water cutoff to turn the unit back on.

17.2 - Removing the casing

In order to remove the casing, follow the steps below while referring to Figure 17-2:

1. Lift up by hands cover "A"
2. remove screws "B";
3. pull back for 2 inches the upper side of cover "C";
4. pull up for one inch cover "C" and remove it from appliance;
5. pull back for 2 inches the upper side of cover "E";
6. pull up for one inch cover "E" and remove it from appliance;
7. pull back from left side the door "D"
8. pull up the fan cover "H";

Now you can gain access to all components inside heater.

To gain access to the junction box:

9. Remove screw "G";
10. Take away cover "F".

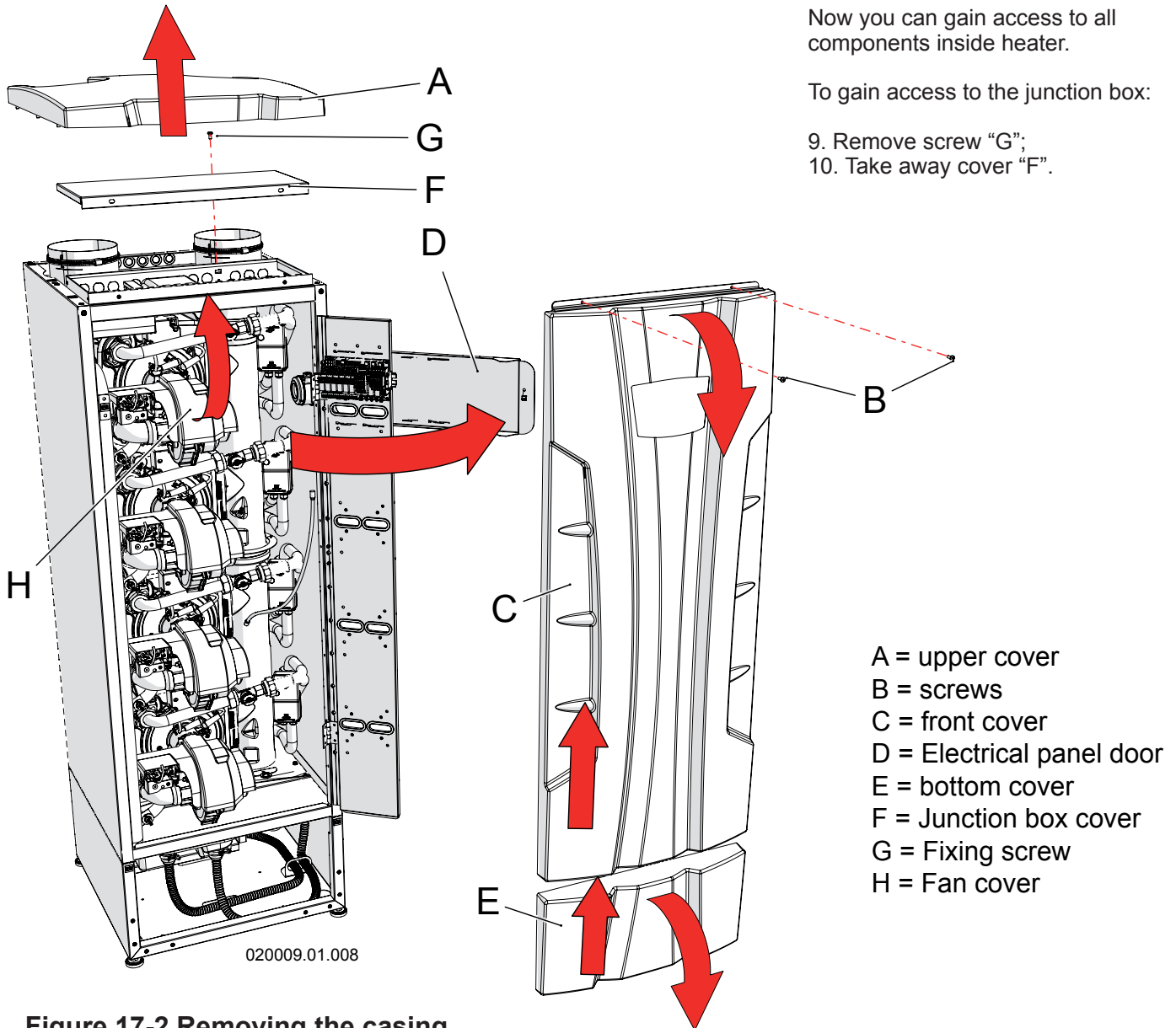

- A = upper cover
- B = screws
- C = front cover
- D = Electrical panel door
- E = bottom cover
- F = Junction box cover
- G = Fixing screw
- H = Fan cover

Figure 17-2 Removing the casing

17 - MAINTENANCE

17.3 - Cleaning the burner and primary heat exchanger, flue gas side

Burner and primary heat exchanger must be checked every year and cleaned if there is presence of debris or products of the combustion. To correctly clean the burner and the flue gas side of the heat exchanger follow the steps below:

! WARNING!!! Before proceeding to the next step, verify that the electrical supply to the heater, and any other electrical supply near the heater, is off. Verify that the manual gas shut off valve is closed. Failure to comply with this warning can cause extensive property damage, severe personal injury or death!

1. follow the steps in Section 17.2 to gain access to the internal components;
2. for units 399 up to 1000, prepare a suitable cover for the burner units below your actual site (if any) so that no dirt, water, or other foreign objects can fall into the burner unit below;
3. loosen screws "D" (Figure 17-3) and move up the spark generator "A" (Figure 17-3);
4. disconnect the two wires "D" (Figure 17-4) from the ignition electrodes and the wire "E" (Figure 17-4) from the flame detection electrode;
5. rotate the air inlet silencer "B" (Figure 17-4) in the up direction;
6. pull in the left direction "C" (Figure 17-4) the air inlet silencer and remove it from the fan;
7. unscrew nut "H" (Figure 17-5). Pay attention to the gasket between nut "H" (Figure 17-5) and the gas valve.
8. take away the spring "A" as per Figure 17-5. Help yourself with a screwdriver;
9. remove the electrical plug from the gas valve;
10. Remove the gas valve from its position (see Figure 17-6). Take care attention to the o-ring "L" of Figure 17-6;

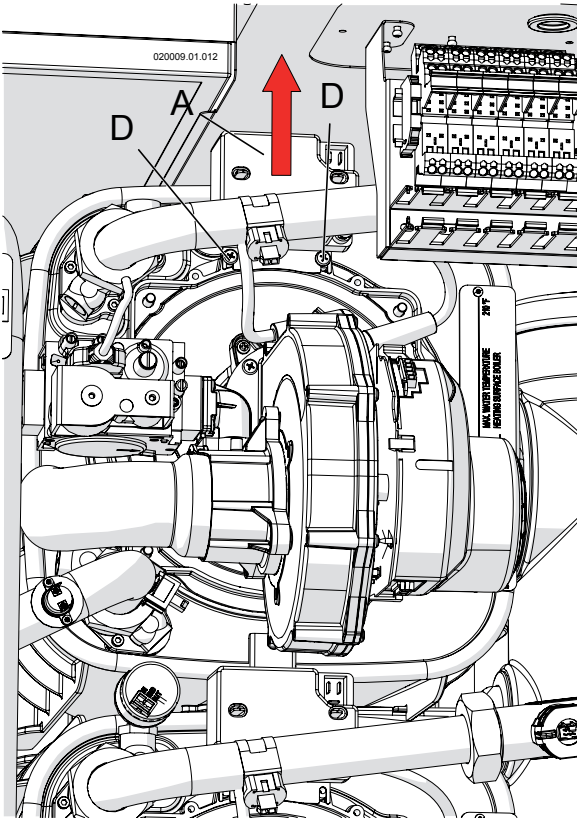

Figure 17-3 Remove the spark generator

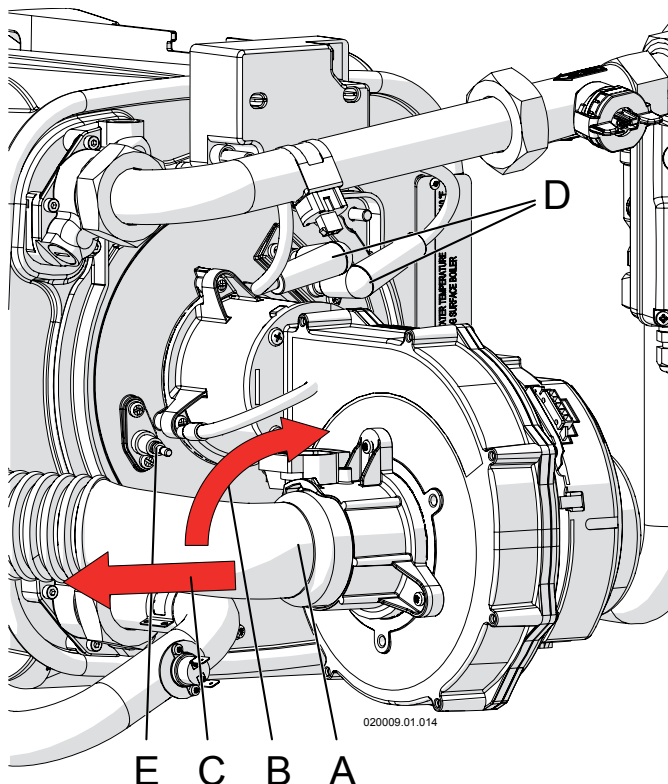

Figure 17-4 Remove the air inlet silencer

17 - MAINTENANCE

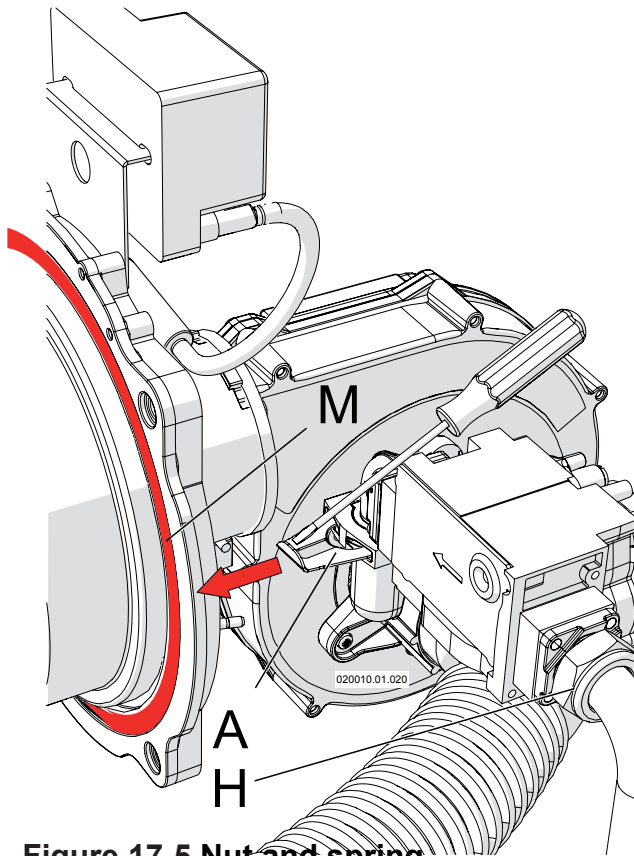

Figure 17-5 Nut and spring that fixes the gas valve

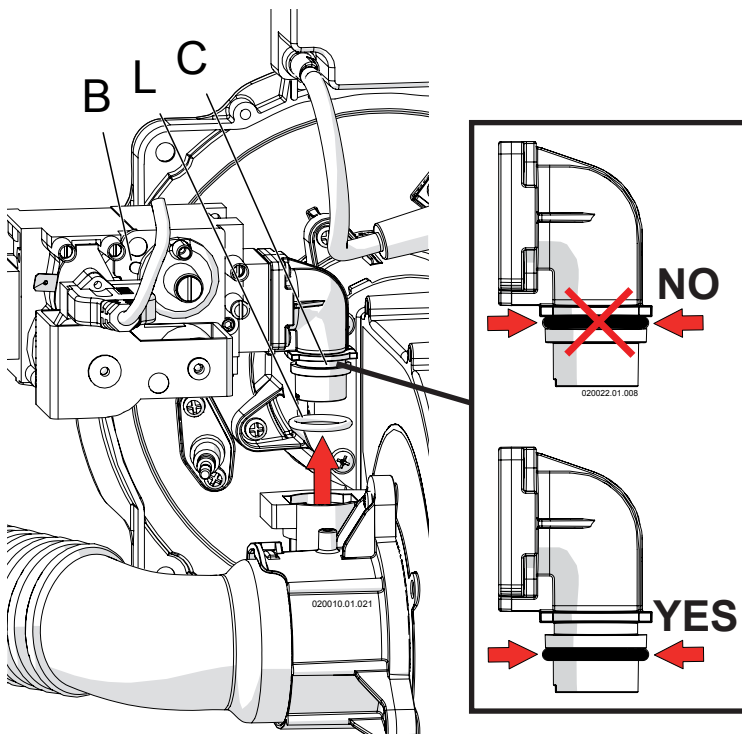

Figure 17-6 Remove the gas valve

11. unscrew the four nuts "B" in Figure 17-7;
12. remove the entire fan - burner assembly, detail "C" in Figure 17-7;
13. use a cylindrical brush with plastic bristles to clean the inside of the combustion chamber, detail "H" in Figure 17-7;
14. use a vacuum cleaner to remove any unburned residue from the combustion chamber "H" in Figure 17-7;
15. using the same vacuum cleaner, clean the surfaces of the burner and around the electrodes;

⚠ WARNING!!! While performing the next step, carefully wash only the inside of the combustion chamber "H" of Figure 17-7, and do not get water on the outside of the combustion chamber opening. Failure to comply with this warning can cause extensive property damage, severe personal injury or death!

16. using only water, wash the inside of the combustion chamber, detail "H" in Figure 17-7. The water, will drain into the condensate drain;
17. replace gasket "M" as per Figure 17-5 (Part number for this gasket is 60703047). Take care that the gasket and its site are clean.

⚠ WARNING!!! Pay attention to the gasket "M" (Figure 17-5) during reassemble. When finished, perform a leakage test with the burner firing. Always use an approved leak detection method. Failure to comply with this warning can cause fire, extensive property damage, severe personal injury or death!

18. reassemble the components by proceeding in reverse order. Pay attention in the reinstalling of gasket between nut "H" of Figure 17-5 and of the o-ring "L" of Figure 17-6. These must be in good condition. If not they must be replaced with;
19. open the manual gas shutoff valve;
20. check that there are no gas leaks;

⚠ WARNING!!! Never use an open flame to test for gas leaks. Always use an approved leak detection method. Failure to comply with this warning can cause fire, extensive property damage, severe personal injury or death!

21. restore electrical power to the heater.

17 - MAINTENANCE

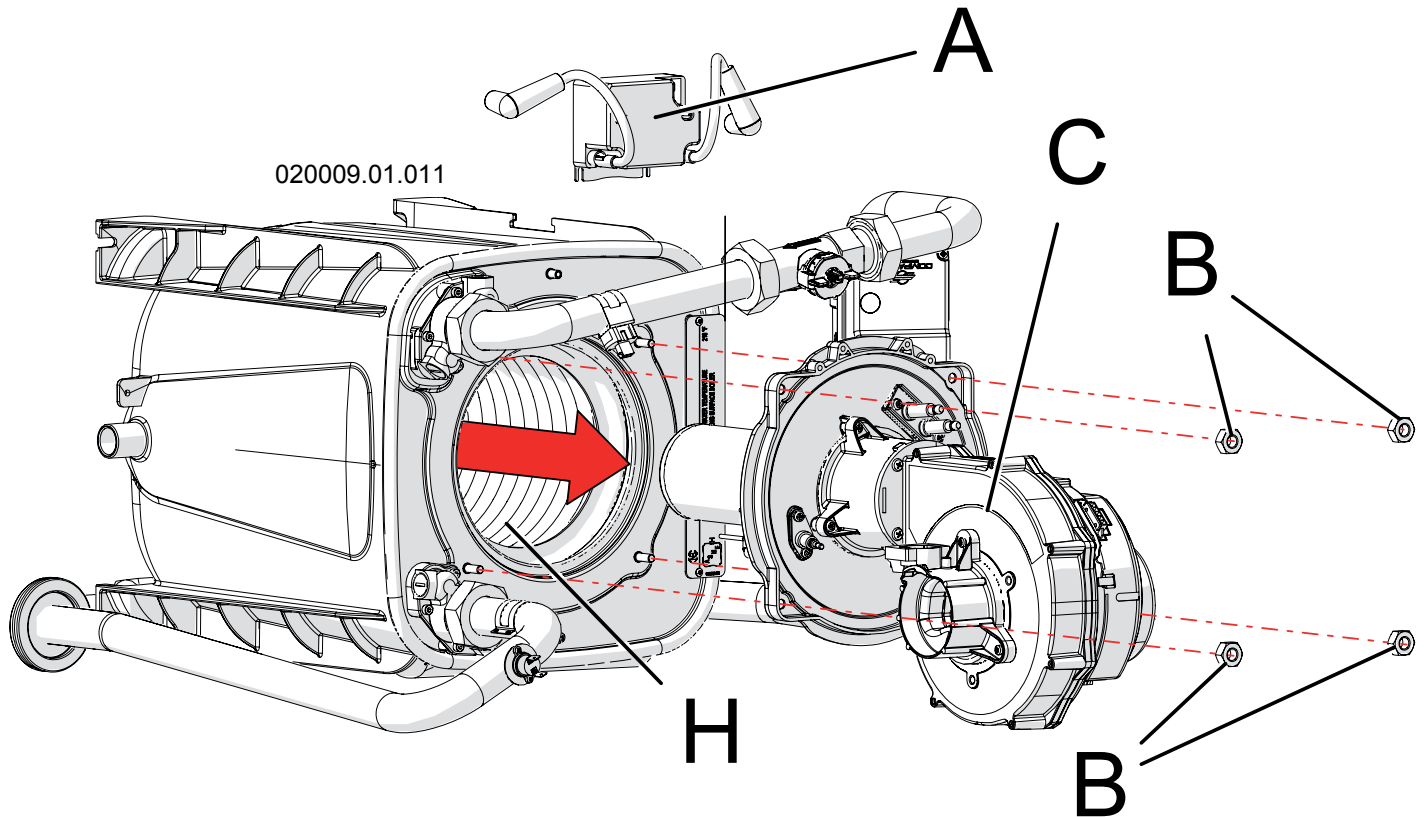
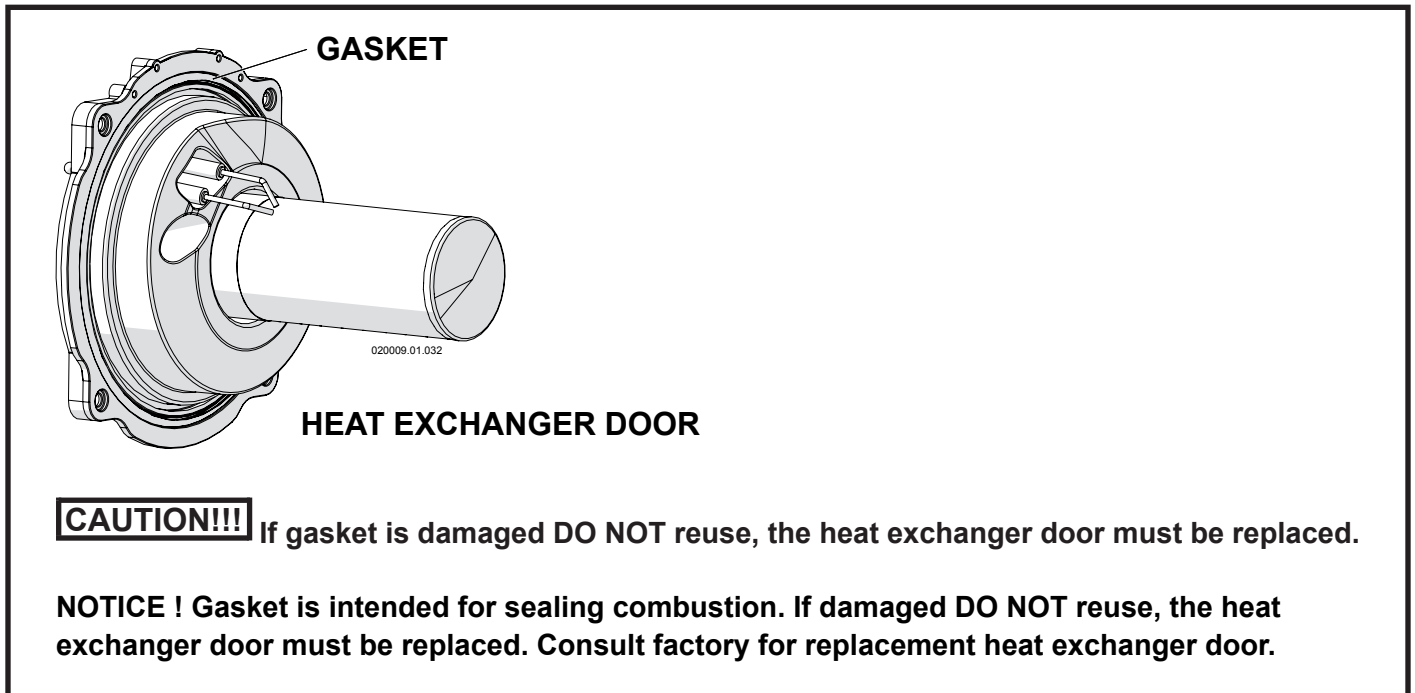

Figure 17-7 Remove the fan burner assembly



17 - MAINTENANCE

17.3.1 - Thermal insulations

Thermal insulations must be checked every year and replaced if they are cracked or damaged. See Figures below where the thermal insulations (items "C" and "E" are shown already disassembled from heat exchanger).

- A = Fixing screw
- B = Washer
- C = Thermal Insulation
- D = Stainless steel tube
- E = Thermal Insulation
- F = White thermal insulation
- G = Burner
- H = Gasket
- L = Ignition electrodes
- M = Screws
- N = Detection Electrode
- Q = White thermal insulation
- R = Gasket
- S = Gasket

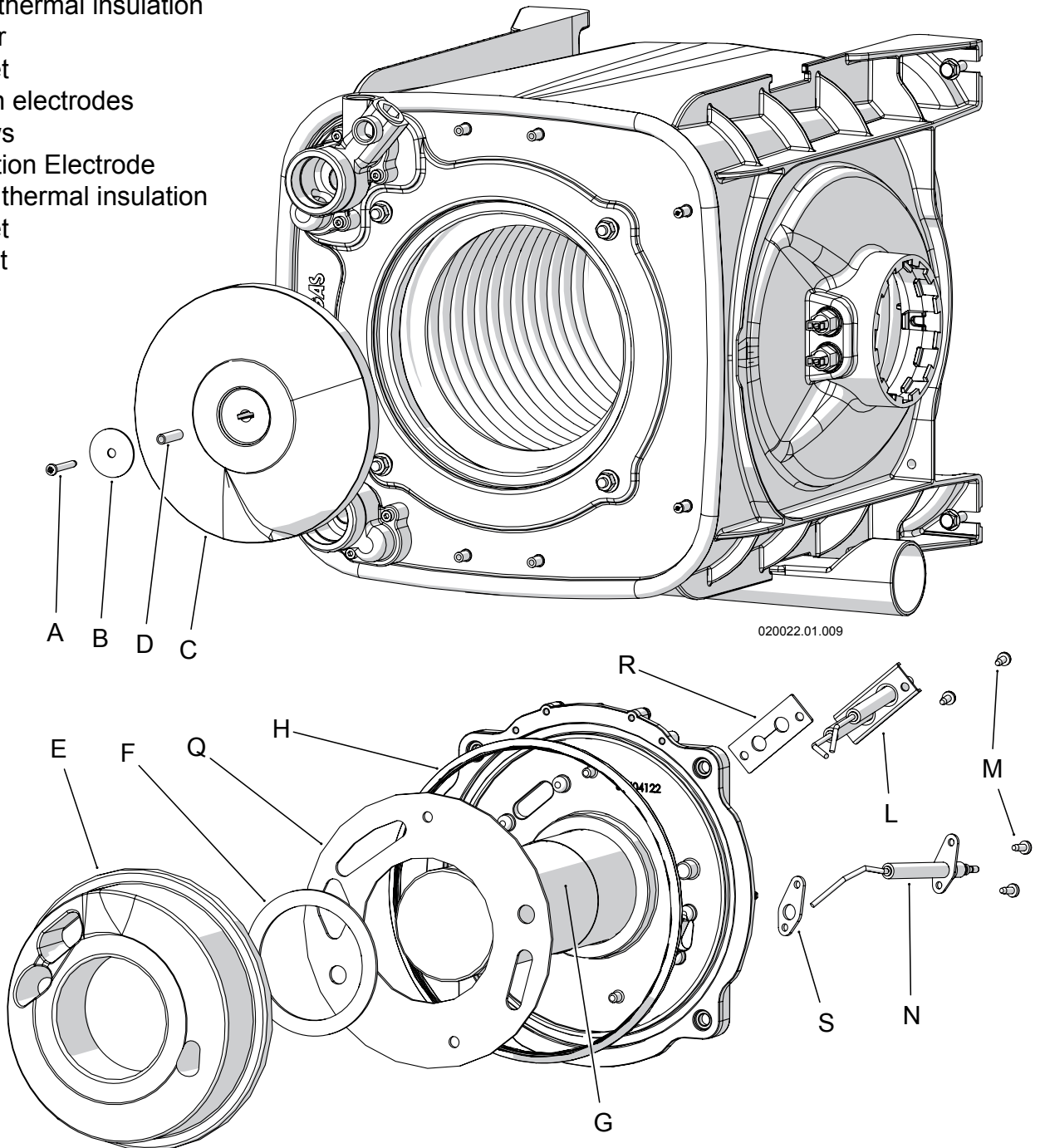

17 - MAINTENANCE

17.4 - Correct positioning of the ignition and flame detection electrodes

For the heater to work properly the electrodes must be positioned as shown in Figure 17-8:

NOTICE! To insure correct functioning of heater the distances listed above shall be verified very carefully also using a hand caliper.

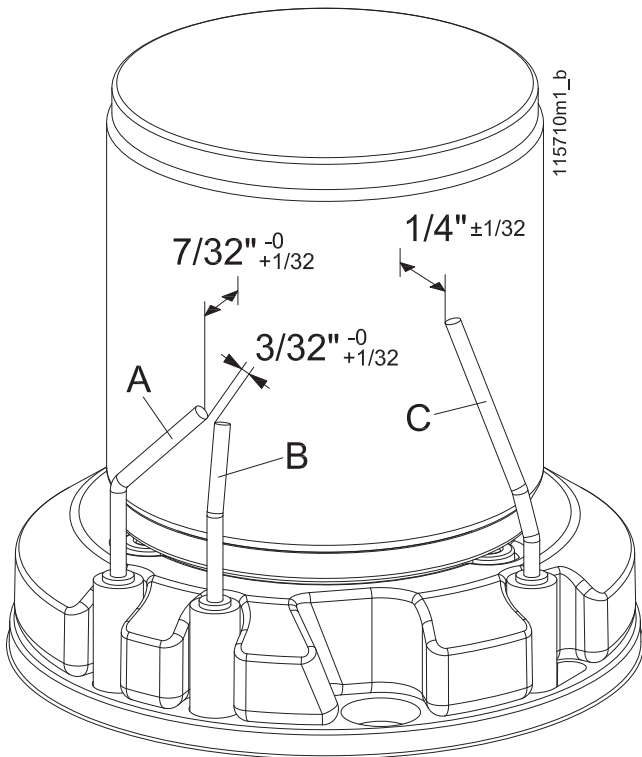

A = Left ignition electrode
B = Right ignition electrode
C = Flame detection electrode

**Figure 17-8 Positioning electrodes on burner
(Use a hand caliper to verify the distances)**

17.5 - Clean the air filter

For the heater to work properly, the air filter must be clean. A dirty air filter can cause a power input reduction of the unit, resulting in system malfunctions. Operate as follows in order to clean the air filter:

1. follow the steps in Section 17.2 to gain access to the internal components;
2. pull down with a rotation the air filter "B" as per Figure 17-9
3. pull back the air filter and remove it from the unit;
4. with compressed air, clean the surface of the air filter;
5. reassemble the air filter.

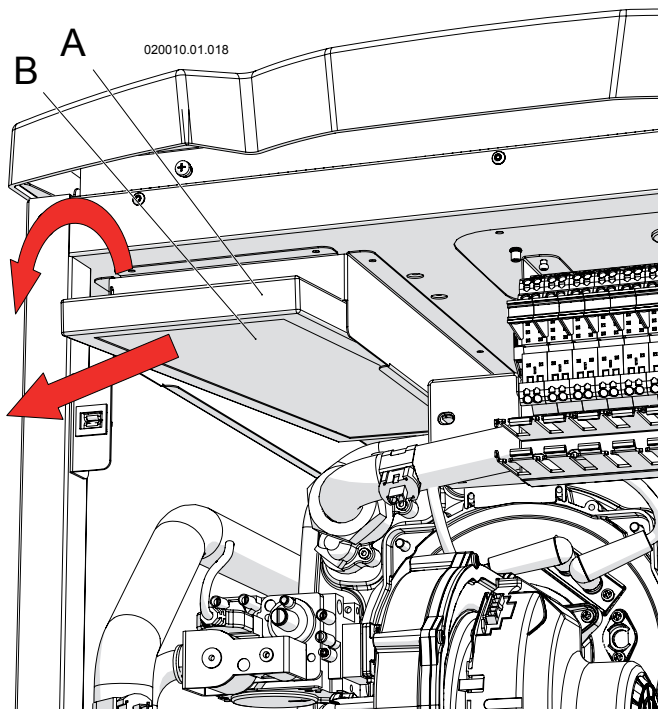

Figure 17-9 Remove the air filter "B"

17 - MAINTENANCE

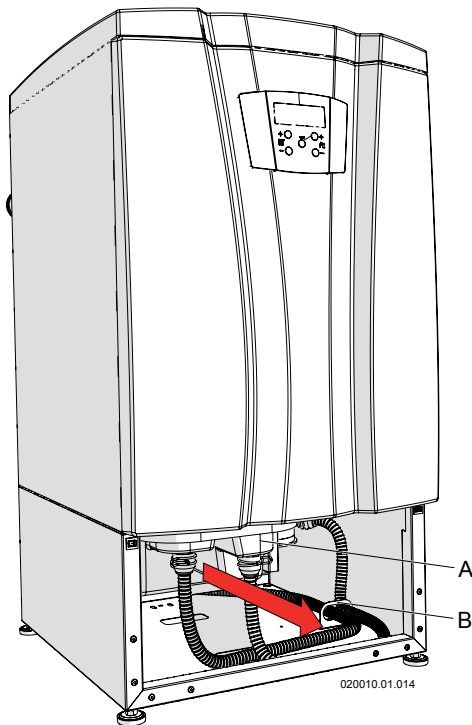

Figure 17-10 Condensate trap and neutralizing box removing

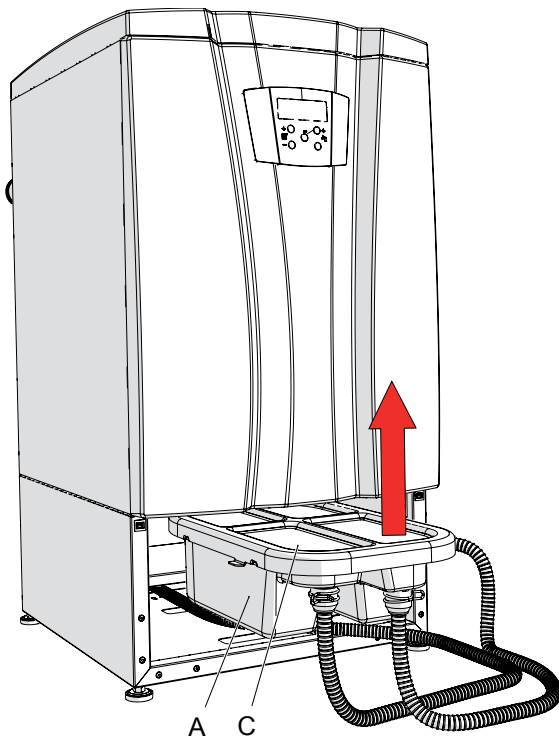

Figure 17-11 Condensate trap and neutralizing box removing

17.6 - Condensate trap and neutralizing box maintenance and cleaning

The condensate trap and neutralizing box must be checked every year and cleaned if required. Follow the steps below to properly inspect, recharge or substitute condensate neutralizing box and media:

Monitor the level of the neutralization media in the box periodically. The pH can be checked after the condensate has exited from pipe "A" of Figure 9-2. Check the pH level every three months for the first year. Use a suitable pH test strip paper or an electronic pH meter for precise measurement. The frequency of checking the pH level can be reduced to every six months or every year depending on the readings obtained compared to local water authority requirements. The neutralizing media should be replaced when the pH level drops below the minimum level of the local water authority. For replacement media contact your local sales representative. How to operate:

1. follow the steps in Section 17.2 to remove cover "E" of Figure 17-2;
2. pull out the condensate box "A" (Figure 17-10);

CAUTION!!!

When the box is pulled out pay attention when placing on the floor, it is full of condensate water. To avoid any leakage from the top, it is suggested to bend box 2 to 5% in the direction of discharge pipes to empty some condensate water. Leaking condensate water may cause severe property damage.

3. open cover "C" (Figure 17-11) in the upper direction;
4. inspect the condensate box making sure the collection box is intact;
5. examine neutralizer media and refill as necessary with fresh media;
6. fill with fresh water until the water begins to flow out of drain;
7. re-install the condensate box;

! WARNING!!!

The condensate collection box must be filled with water to prevent flue gas emissions from escaping during unit operation. Failure to comply with this requirement can result in excessive levels of carbon monoxide which can cause severe personal injury or death!

8. open the manual gas shutoff valve;
9. restore electrical power to the heater.

! WARNING!!!

The condensate neutralizer box must be kept correctly installed into the unit, like shown in Figures 3-3 through 3-10 item "3". Correctly reinstall the condensate collection into its position. Incorrectly reinstall the condensate collection box into position will result in combustion gases entering the room. This can result in excessive levels of carbon monoxide which can cause severe personal injury or death!

17 - MAINTENANCE

17.7 - Connection of the display to other burners

On multi-burner unit models 399 up to 1000, display of Figure 16-1, is always connected directly to "Burner 1 (Master)". All parameters read in the display (see Sections 16.13, 16.14 and 21), addressed to "Burner 1 (Master)" are related exclusively to this burner. If you want to see/change, the same parameters for other burners, you have to move the display connection from "Burner 1 (Master)" to the corresponding burner. To do so, operate as follows (make reference to Figure 17-12):

1. turn off the electrical power;
2. follow the steps in Section 17.2 to remove the cover and gain access to the internal components;
3. disconnect plug "B" (plug coming from display) from plug "A" (plug coming from "Burner 1 (Master)");
4. connect plug "B" to the plug "C", "D", or "E" follow which burner you want to question, considering that: plug "C" is for "Burner 2"; plug "D" is for "Burner 3" and plug "E" is for "Burner 4";
5. once you moved the display plug, turn on power to the appliance;
6. now display will show all information related to the burner where it is connected. To make any change follow Sections 16.13, 16.14 and 21;
7. once you terminate the query, connect again the plug "B" on the original plug "A".

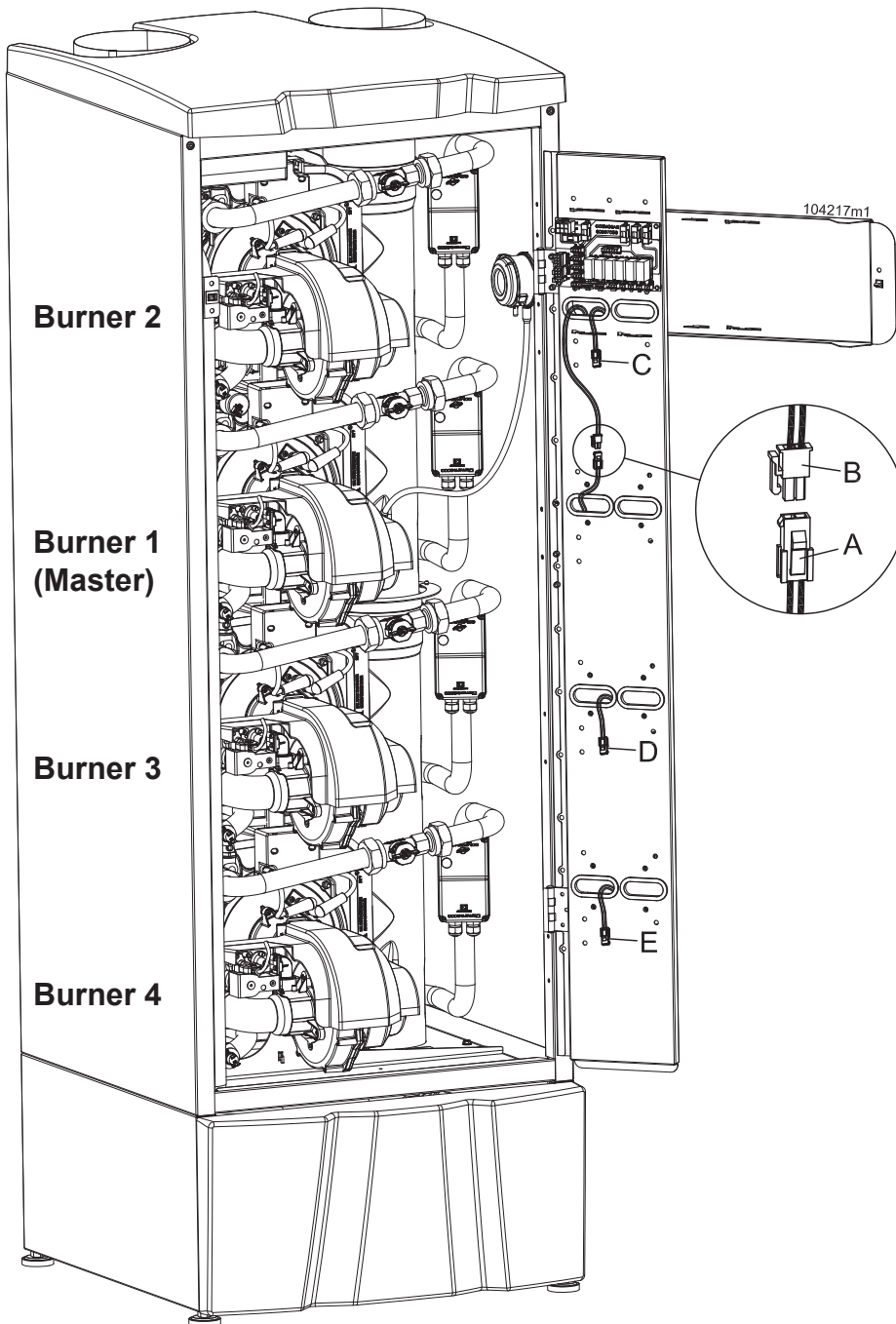

- A = Connector coming from Burner 1 (Master)
- B = Connector coming from display
- C = Connector coming from Burner 2
- D = Connector coming from Burner 3 (Present only on models 750 and 1000)
- E = Connector coming from Burner 4 (Present only on model 1000)

Figure 17-12 Connection of the display in other burner units

17 - MAINTENANCE

17.8 - How to move a control board

Multi-burner unit models 399 to 1000 are configured to be driven by one control board (named Burner 1 (Master)). On this board all external devices are connected, such as: room thermostat, outdoor sensor, pumps commands, LWCO, and some internal safety devices such as: blocked drain magnetic switch, flue blocked pressure switch, etc.

If Burner 1 control board fails, the complete unit stops working. If the installer doesn't have a replacement part, it can replace Burner 1 control board for another installed on the unit and reactivate it.

To do so, operate as follows:

1. turn off the electrical power;
2. follow the steps in Section 17.2 to remove the cover and gain access to the internal components;
3. disconnect plug "B" (plug coming from display) from plug "A" (plug coming from "Burner 1 (Master)");
4. disconnect all other plugs from Burner 1 (Master) control board;
5. remove the Burner 1 (Master) control board from the appliance;
6. following step 3 to 5 above to remove the board located in the lower side of the unit;
7. install this last control board in the site where there where the Burner 1 (Master) control board;
8. reconnect all plugs to this board;
9. move "Switch S4" as per Figure 17-13, from OFF position to ON position;
10. pay attention that all connections of the board removed are not in short circuit or in a dangerous position;
11. electrically insulate each one of these plugs;
12. close the external jacket of the unit;
13. turn the electrical power on to the unit;
14. gain access to the Factory menu, by following Section 21 and set all parameters by following column "Burner 1 (Master)" (pay attention to parameter 3050. Because you are moving a board to the master, the 3050 value must be reduced by one unit);
15. shut off electrical power to the unit;
16. turn on the power to the unit. Now the new Burner 1 control board should drive the unit correctly.

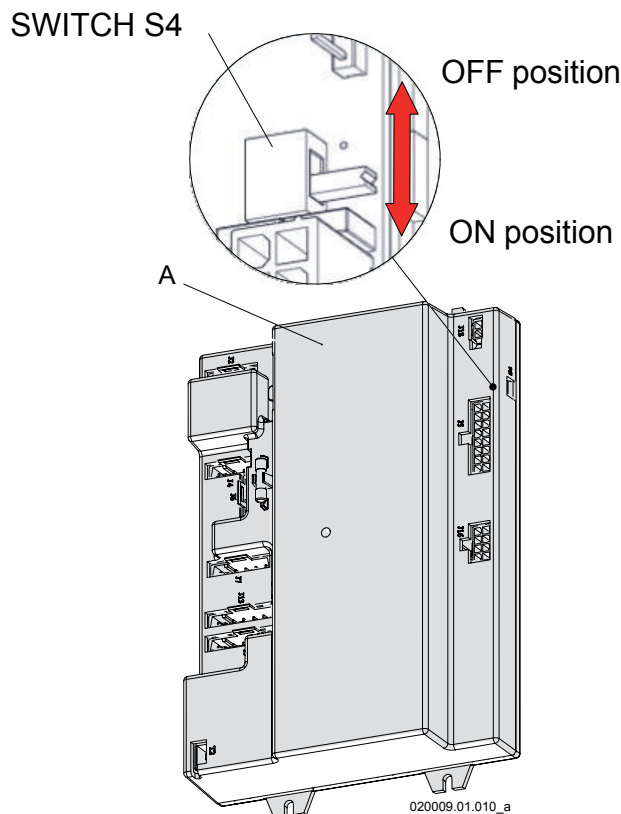

Figure 17-13 Control board "A"

17- MAINTENANCE

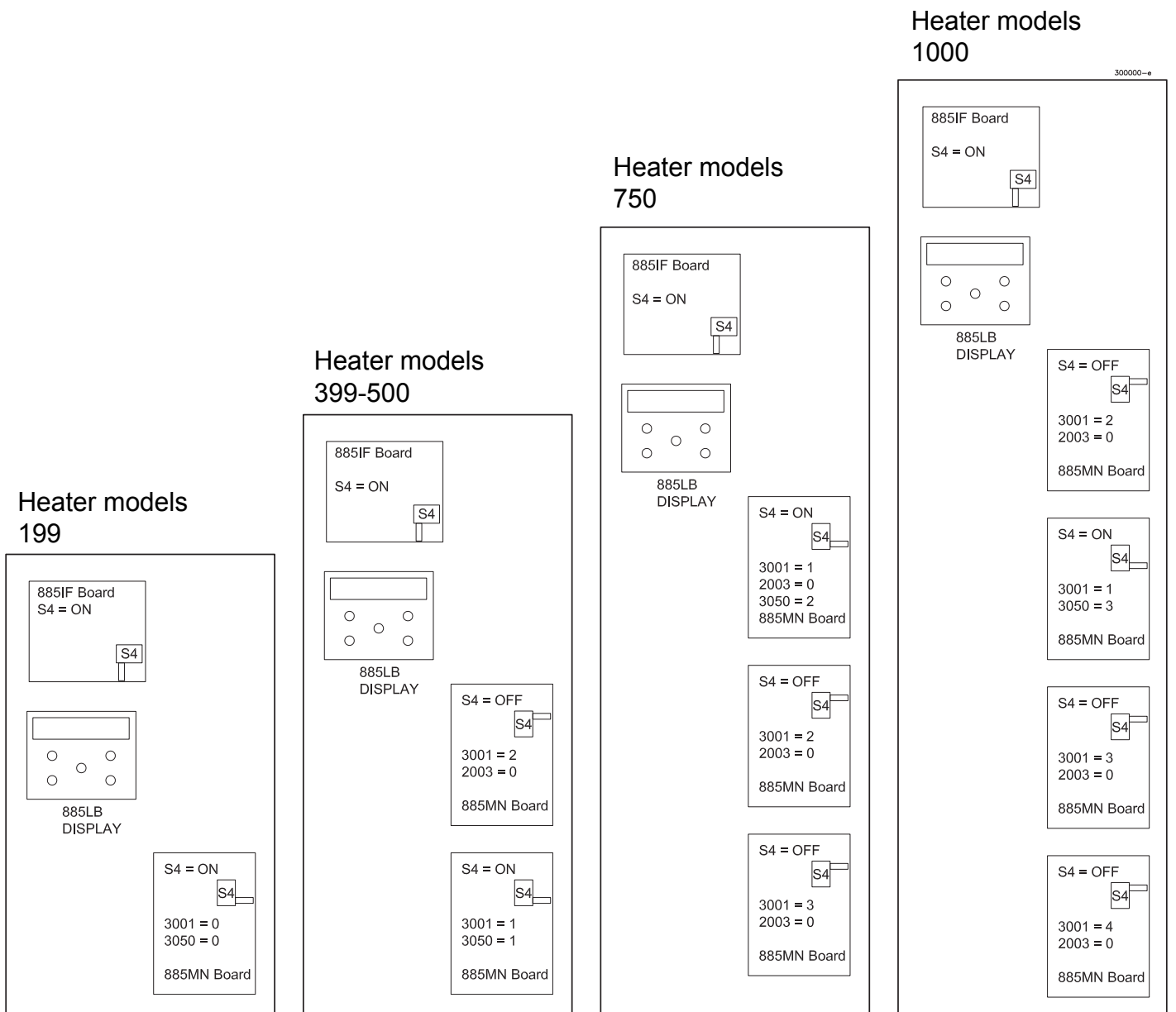



Figure 17-14 Complete situation of addresses and switches S4

17.9 - Draining the water from the heater

To drain the water from the unit, follow the steps below:

1. set the control temperature to the maximum (see section 16.6 and 16.7) and wait for all icons relative to the burners (items "L" of Figure 16-1) to light. This indicates the eventual motorized valves (item "17" of Figure 3-1) are open;
2. turn the power off to the heater in a way that all the motorized valves stop in open position;
3. close the manual gas shutoff valve, Figure 14-1;
4. wait until the water temperature decreases to below 104°F (40°C);
5. close the heater isolation valves, in the heating system. If isolation valves haven't been installed, the entire heating system will have to be drained;
6. check that the heating system fill valve is closed;
7. connect a hose to the drain valves item "38" of Figures 3-5, 3-8 and 3-11 and place the other end of the hoses in a sink or some other suitable drain;
8. open the drain valves and wait for all water to drain;
9. if unit isolation valves have not been installed, open any bleed valves at the highest point of the system;
10. after draining out all the water, close the bleed valves and the unit drain valves.

NOTICE! The heater cannot be drained completely of water without purging the unit with an air pressure of 30 psi.

 **WARNING!!!** Do not recover and/or re-use water drained from the heating circuit for any purpose as it could be contaminated. Failure to comply with this warning can cause extensive property damage, severe personal injury or death!

17- MAINTENANCE

17.10 - Water and flue temperature sensor

The heater has a number of sensors that measure temperature. The electrical resistance between the sensor wires must correspond with the values shown in Figure 17-15.

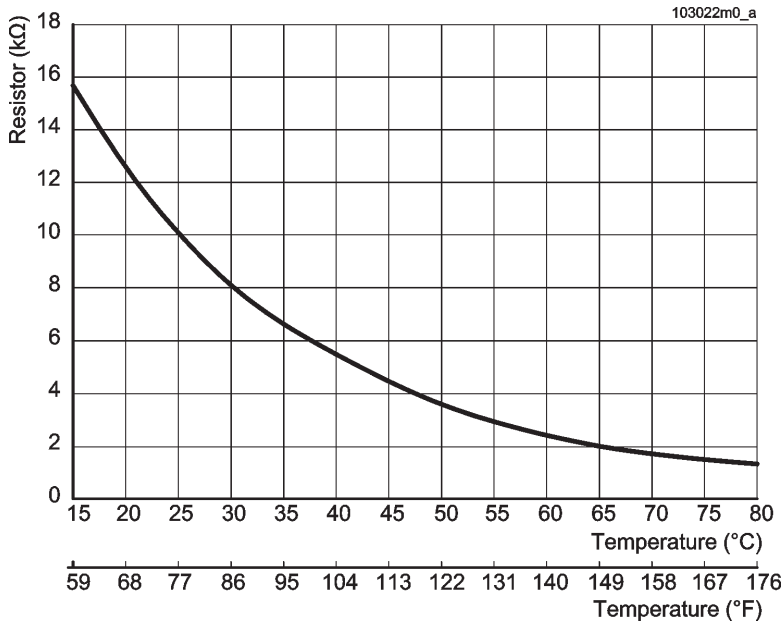

Figure 17-15 Water and flue temperature sensors' curve

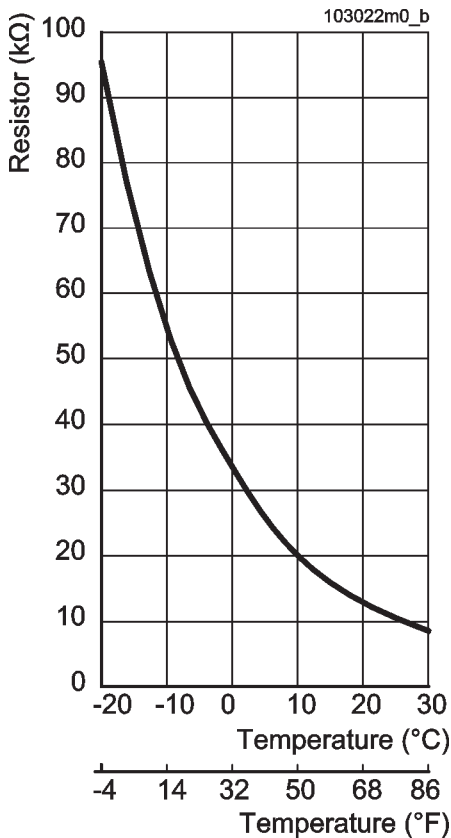

Figure 17-16 Outdoor temperature sensor curve

17.11 - Outdoor temperature sensor

An outdoor temperature sensor can be connected to the heater (see section 10.1.3). The electrical resistance existing between the sensor wires must correspond with the values shown in Figure 17-16.

17 - MAINTENANCE

17.12 - 199 model wiring diagram

For the legend see section 17.13.

! WARNING!!! Label all wires prior to disconnection when servicing controls. Wiring errors can cause improper and dangerous operation! Verify proper operation after servicing. Failure to comply with this warning can cause extensive property damage, severe personal injury or death!

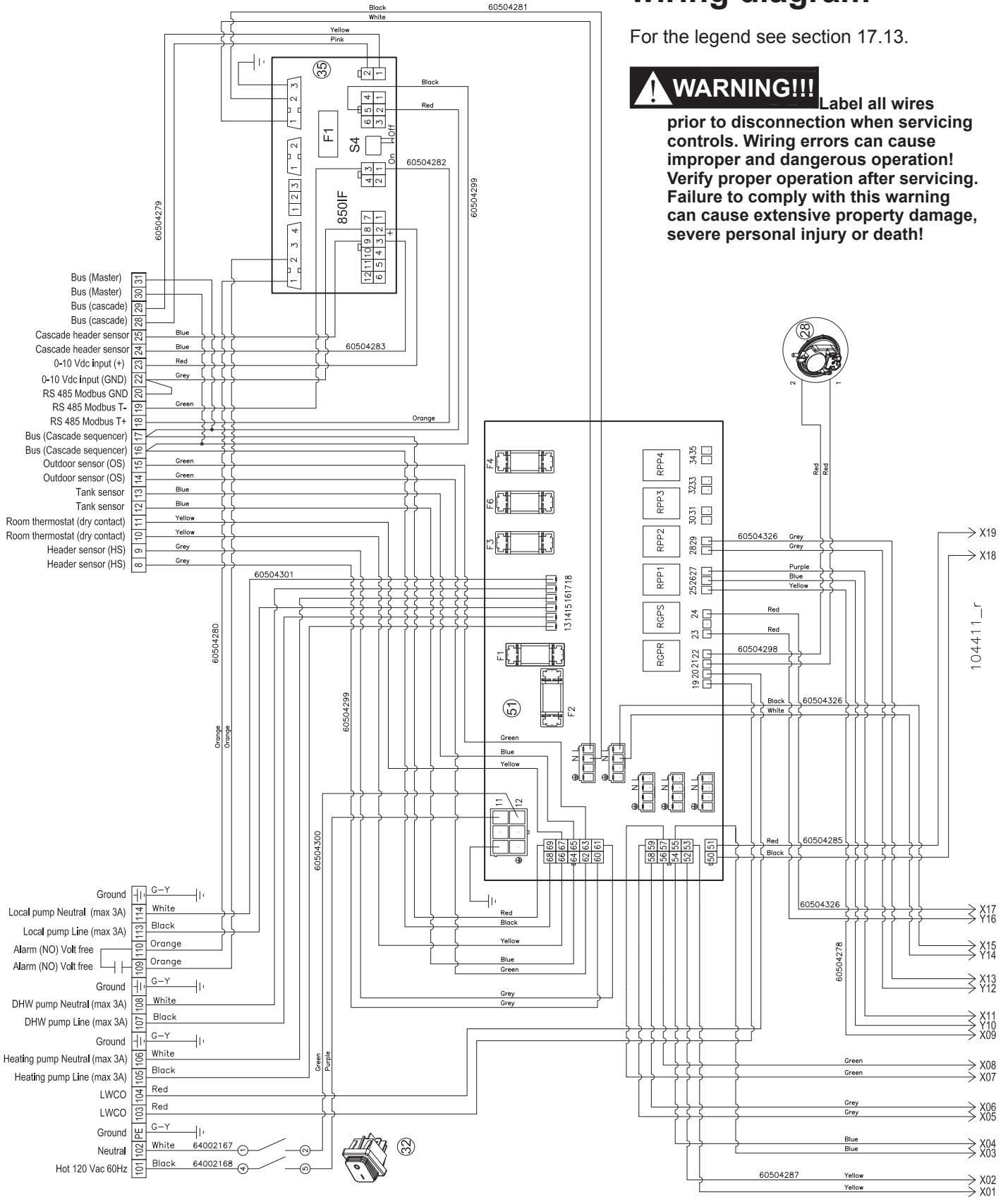

17 - MAINTENANCE



ATTENTION!!!

Au moment de l'entretien des commandes, étiquetez tous les fils avant de les débrancher. Des erreurs de câblage peuvent entraîner un fonctionnement inadéquat et dangereux. S'assurer que l'appareil fonctionne adéquatement une fois l'entretien est terminé.

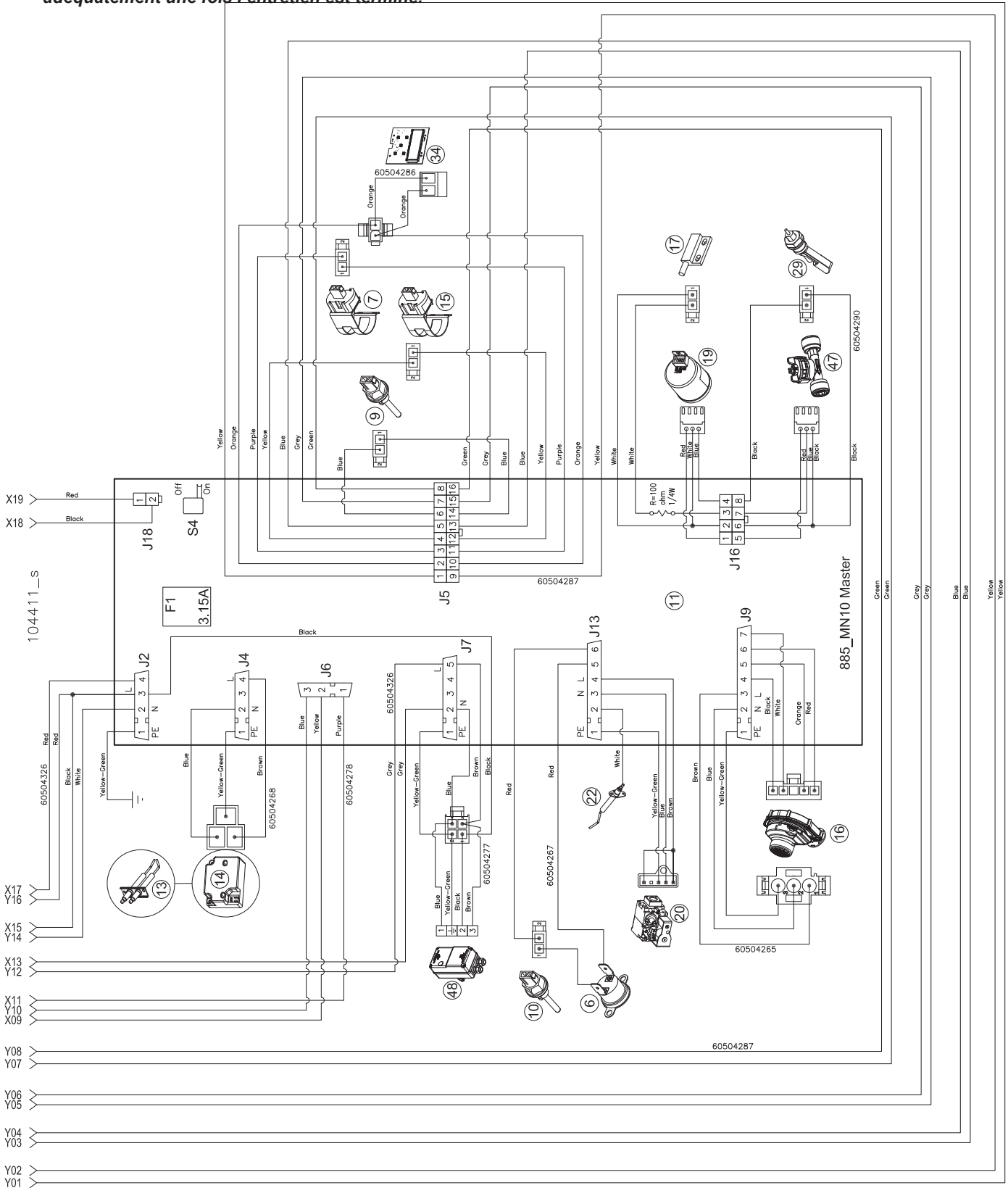

17 - MAINTENANCE

17.13 - 399 to 1000 models wiring diagram



WARNING!!! Label all wires prior to disconnection when servicing controls. Wiring errors can cause improper and dangerous operation! Verify proper operation after servicing. Failure to comply with this warning can cause extensive property damage, severe personal injury or death!

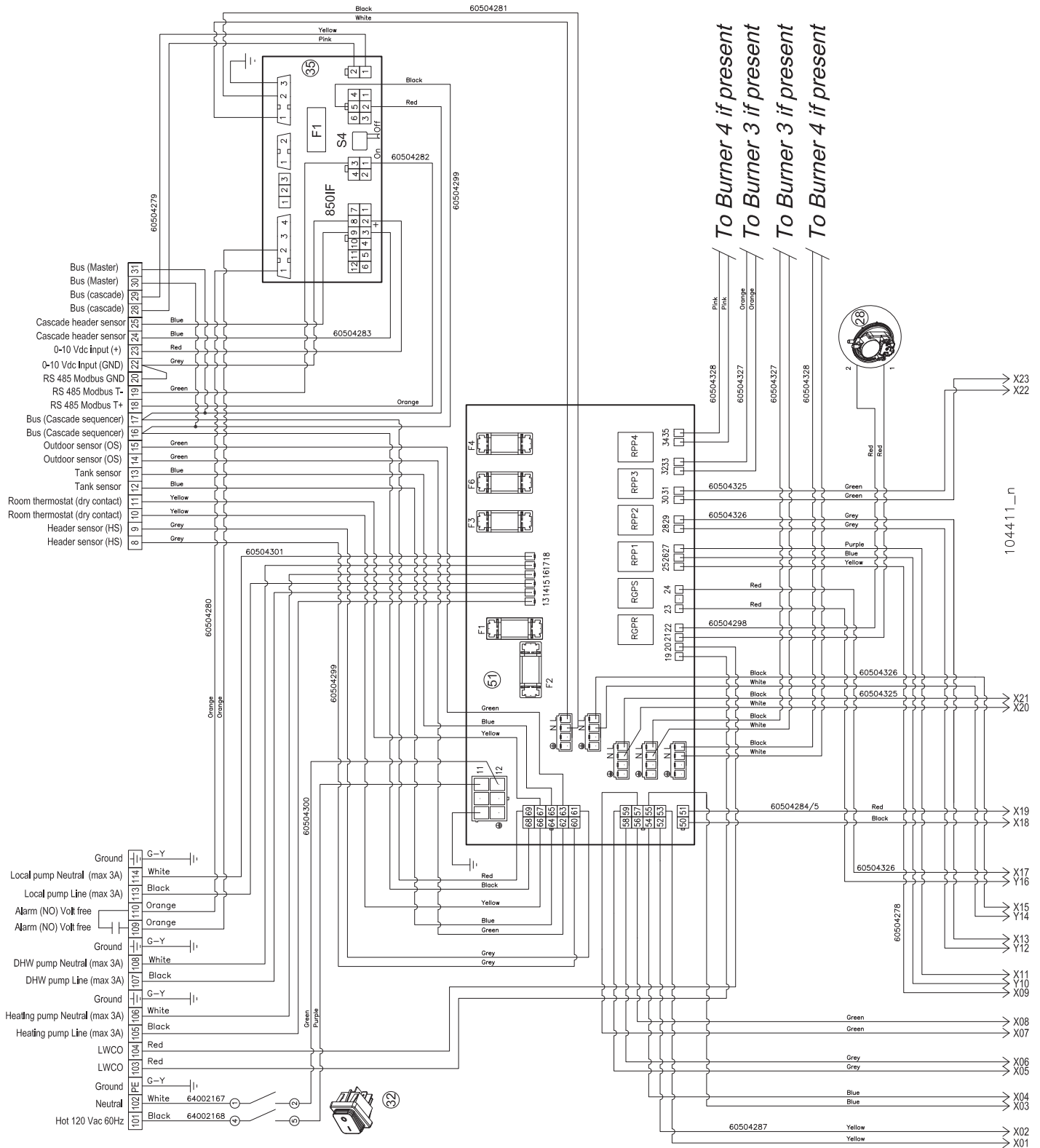

17 - MAINTENANCE



ATTENTION!!!

Au moment de l'entretien des commandes, étiquetez tous les fils avant de les débrancher. Des erreurs de câblage peuvent entraîner un fonctionnement inadéquat et dangereux. S'assurer que l'appareil fonctionne adéquatement une fois l'entretien est terminé.

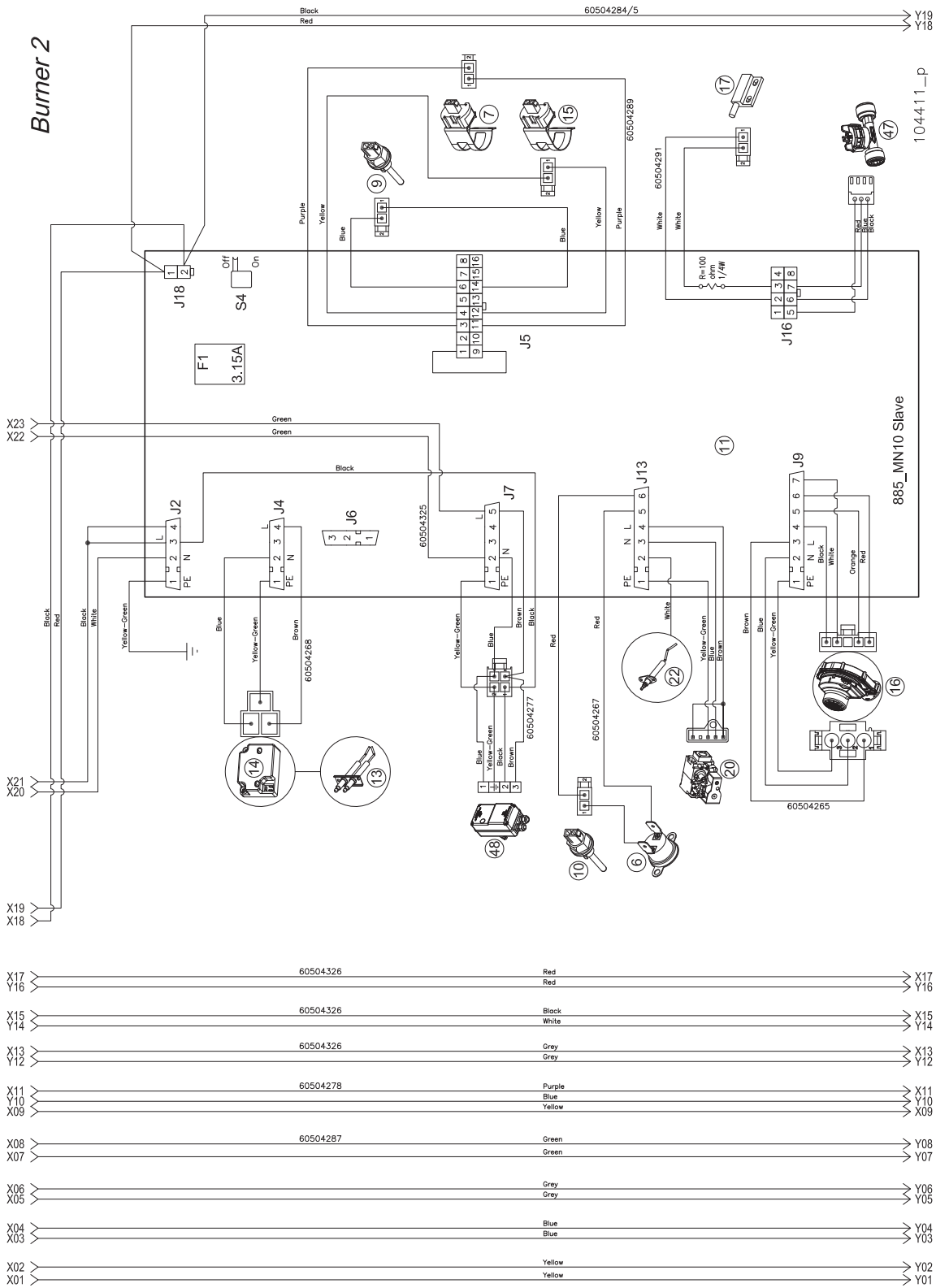

17 - MAINTENANCE

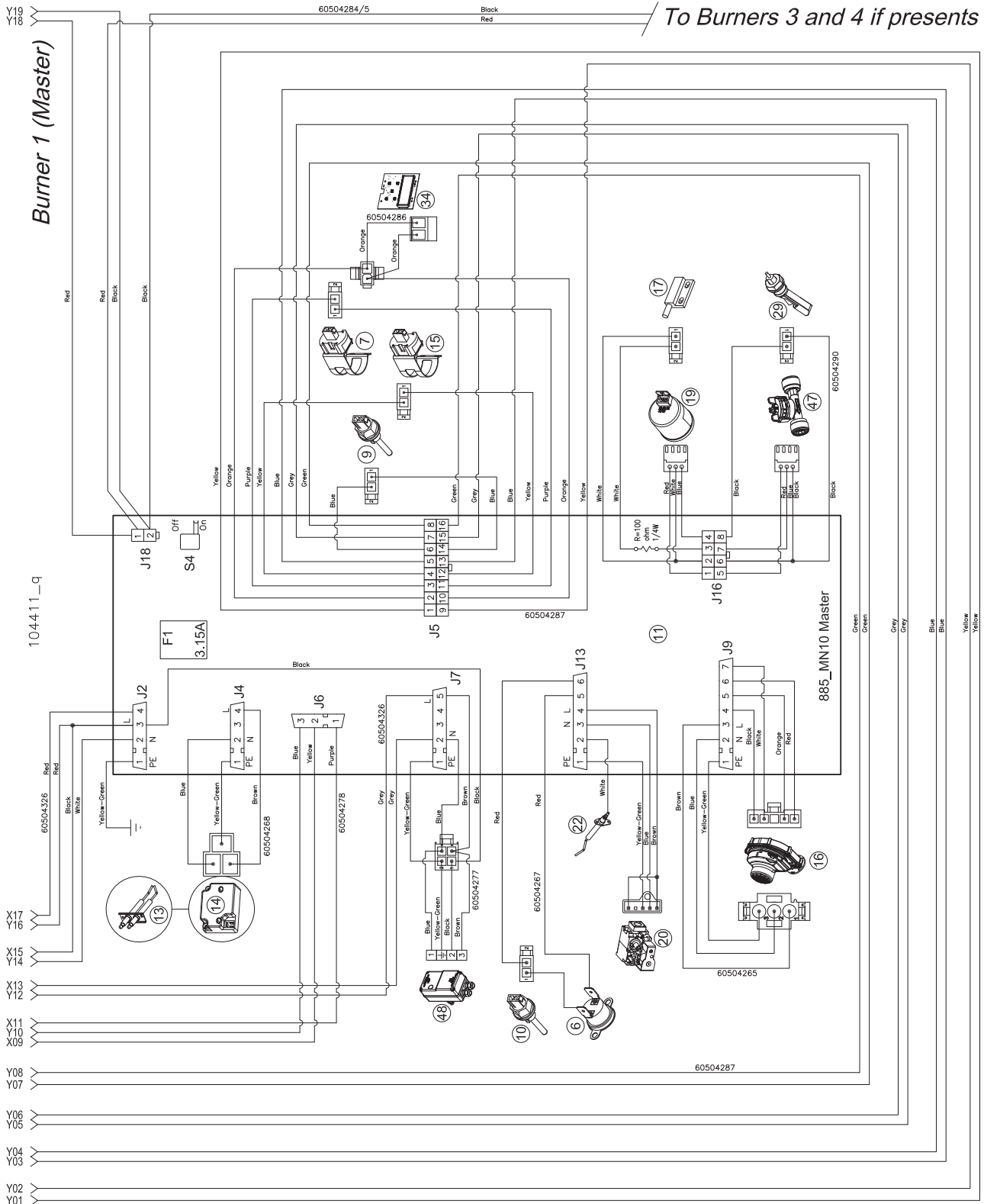

17 - MAINTENANCE

Legend to electrical schemes:

- 6 - High limit supply temperature switch
- 7 - Supply temperature sensor
- 9 - Flue gas temperature sensor
- 10 - High limit flue gas temperature fuse
- 11 - Control board
 - Fuse - F1 5x20 3A
- 13 - Ignition electrodes
- 14 - Spark generator
- 15 - Return temperature sensor
- 16 - Modulating PWM fan
- 17 - Back flue preventer switch (Flapper valve switch)
- 19 - Water pressure sensor
- 20 - Gas valve
- 22 - Detection electrode
- 28 - Blocked flue pressure switch
- 29 - Condensate blocked drain switch
- 32 - Main electrical switch
- 34 - Display
- 35 - IF 885 board (Optional on 199 version)
 - Fuse - F1 5x20 3A
- 47 - Water Flow meter
- 48 - Motorized valve (optional)
- 51 - Connection board
 - Fuse - F1 5x20 10A
 - Fuse - F2 5x20 10A
 - Fuse - F3 5x20 3A
 - Fuse - F4 5x20 3A
 - Fuse - F6 5x20 3A
- RGPR - CH pump relay
- RGPS - DHW pump relay
- RPP1 - Local pump relay of Burner 1 (Master)
- RPP2 - Local pump relay of Burner 2
- RPP3 - Local pump relay of Burner 3
- RPP4 - Local pump relay of Burner 4

18 - TECHNICAL DATA

Heater MODEL		199
Category of discharge chimney		II and IV
Maximum heat input	Btu/hr	199,500
Minimum heat input	Btu/hr	50,000
Turndown ratio		4:1
Number of burners		1
Gas flow rate (Natural gas)	ft ³ /hr	199.5
Gas flow rate (LP gas)	ft ³ /hr	80
Min / Max gas pressure (Nat. and LP)	In.W.C.	3 / 13
Min / Max water temperature	°F	68 / 180
Min / Max water pressure	PSI	8 / 160
Minimum water flow with motorized valves	GPM	11
Minimum water flow without motorized valves	GPM	11
Content of water	gal	1.7
Supply voltage / Frequence		120Vac 60Hz
Absorbed electric power	W	110
Air intake / Flue gas pipes diameter	inch	3
Max. length venting system	ft	120
CO (Carbon monoxide) with natural gas	ppm	<150
CO (Carbon monoxide) with LP gas	ppm	<250
NOx (0% O ₂ with natural gas)	ppm	<30
CO ₂ (Carbon dioxide) for Natural gas at high fire	%	8.4 to 8.7
CO ₂ (Carbon dioxide) for Natural gas at low fire	%	8.4 to 8.7
CO ₂ (Carbon dioxide) for LP gas at high fire	%	9.5 to 10
CO ₂ (Carbon dioxide) for LP gas at low fire	%	10.5 to 11.5
O ₂ (Oxygen) for Natural gas at high fire	%	5.9 to 5.4
O ₂ (Oxygen) for Natural gas at low fire	%	5.9 to 5.4
O ₂ (Oxygen) for LP gas at high fire	%	6.4 to 5.6
O ₂ (Oxygen) for LP gas at low fire	%	4.8 to 3.4
Ionisation current	uA (Micro Amps)	4 to 7
Maximum flue gas temperature	°F	203
Max. negative pressure allowed in the fumes exhaust/intake system	InWC	0.2
Maximum water condensate flow	GPM	0.032
Average acidity of condensation	PH	4
Heater weight (empty of water)	lb	211
Recovery Rating (100°F rise) (water heater only)	Gal/hr	227
DHW delivery (75°F rise) (water heater only)	GPM	5

18 - TECHNICAL DATA

399	500	750	1000
II and IV	II and IV	II and IV	II and IV
399,000	500,000	750,000	999,000
50,000	50,000	50,000	50,000
8:1	10:1	15:1	20:1
2	2	3	4
399	500	750	999
160	200	300	400
3 / 13	3 / 13	3 / 13	3 / 13
68 / 180	68 / 180	68 / 180	68 / 180
8 / 160	8 / 160	8 / 160	8 / 160
11	12	12	12
22	24	36	48
3.4	4	7	9
120Vac 60Hz	120Vac 60Hz	120Vac 60Hz	120Vac 60Hz
220	300	430	591
4	4	6	6
120	120	120	120
<150	<150	<150	<150
<250	<250	<250	<250
<30	<30	<30	<30
8.4 to 8.7	8.8 to 9.1	8.8 to 9.1	8.8 to 9.1
8.4 to 8.7	8.8 to 9.1	8.8 to 9.1	8.8 to 9.1
9.5 to 10	9.5 to 10	9.5 to 10	9.5 to 10
10.5 to 11.5	10.5 to 11.5	10.5 to 11.5	10.5 to 11.5
5.9 to 5.4	5.2 to 4.7	5.2 to 4.7	5.2 to 4.7
5.9 to 5.4	5.2 to 4.7	5.2 to 4.7	5.2 to 4.7
6.4 to 5.6	6.4 to 5.6	6.4 to 5.6	6.4 to 5.6
4.8 to 3.4	4.8 to 3.4	4.8 to 3.4	4.8 to 3.4
4 to 7	4 to 7	4 to 7	4 to 7
203	203	203	203
0.2	0.2	0.2	0.2
0.064	0.077	0.116	0.154
4	4	4	4
312	323	464	548
455	570	855	1138
10.1	12.7	19	25.4

Spare parts

Spare parts for models:

199

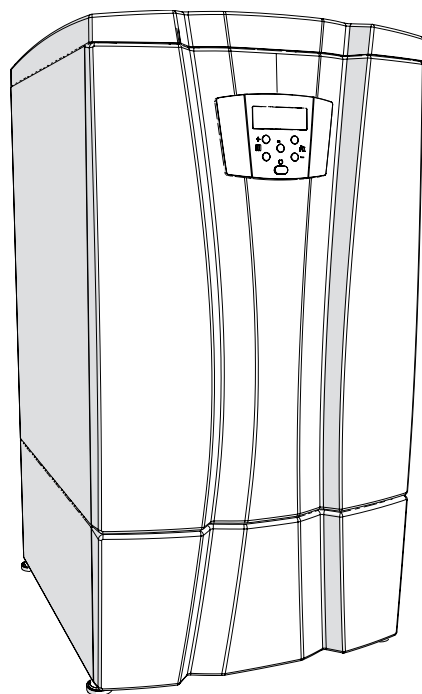

DESCRIPTION	MOD	DESCRIPTION	MOD
BOILER 199	A	WATER HEATER 199	C

WARNING!!! Only use the heater in combinations and with the spare parts listed in this manual. Failure to do so can cause severe personal injury or death.

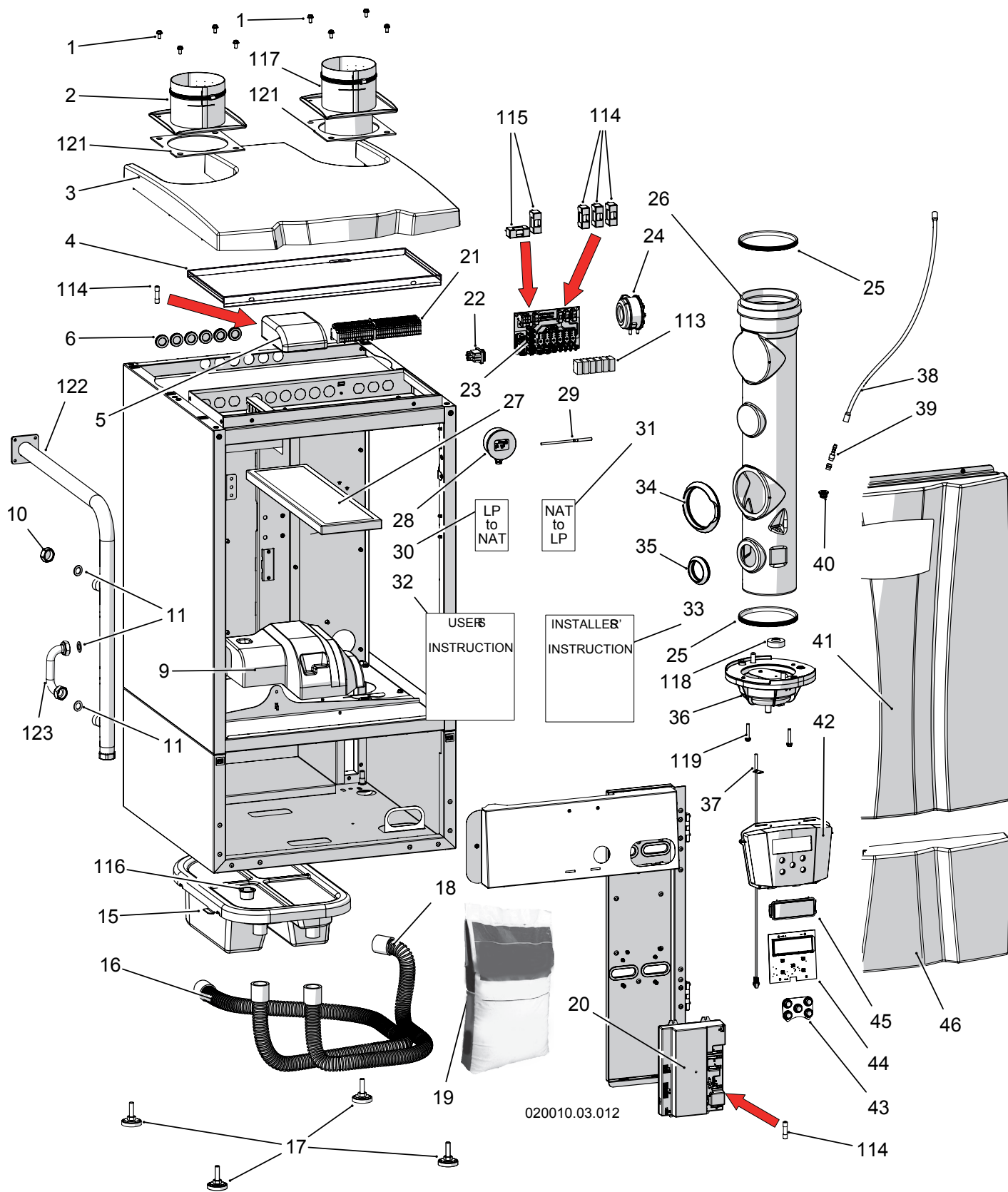

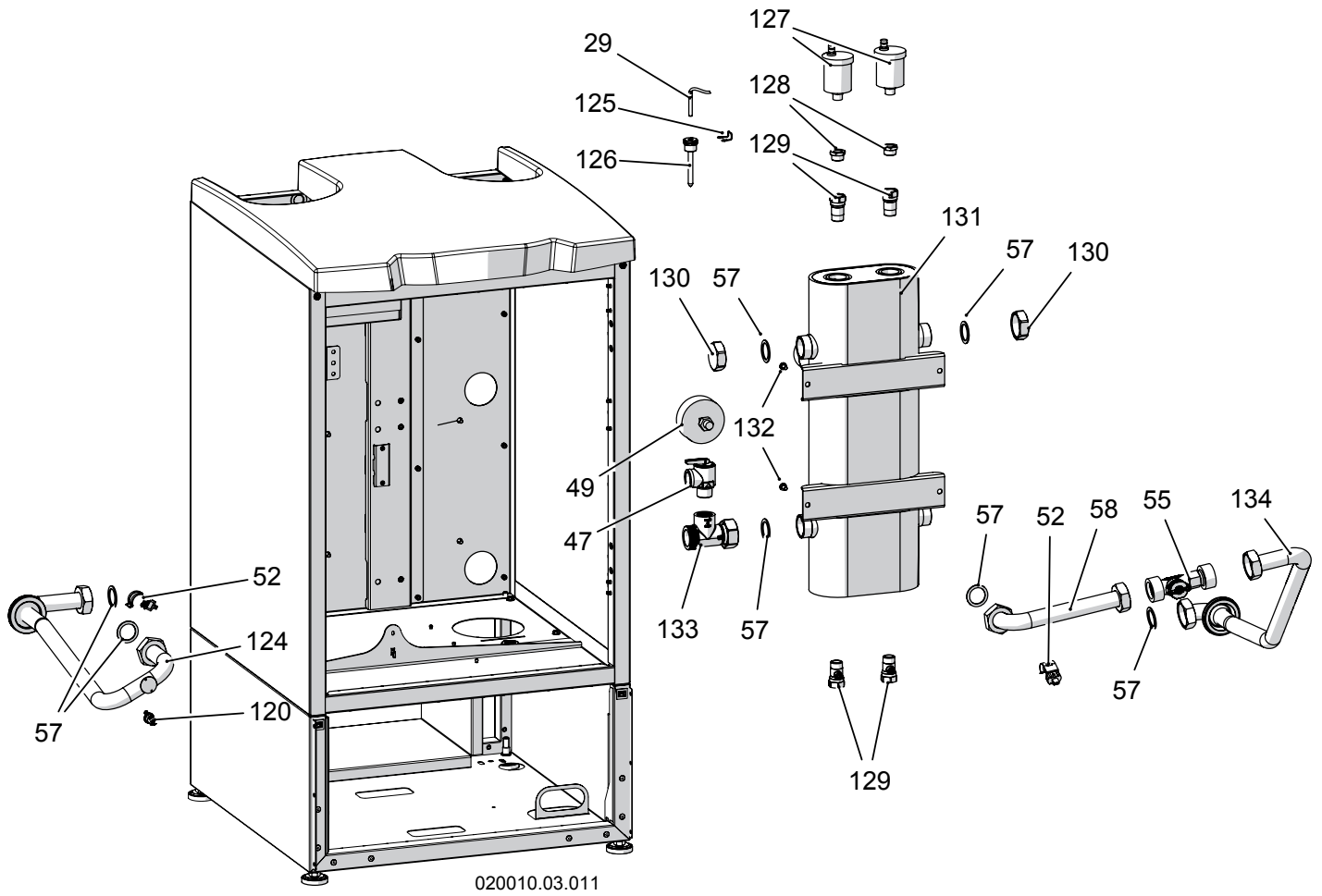

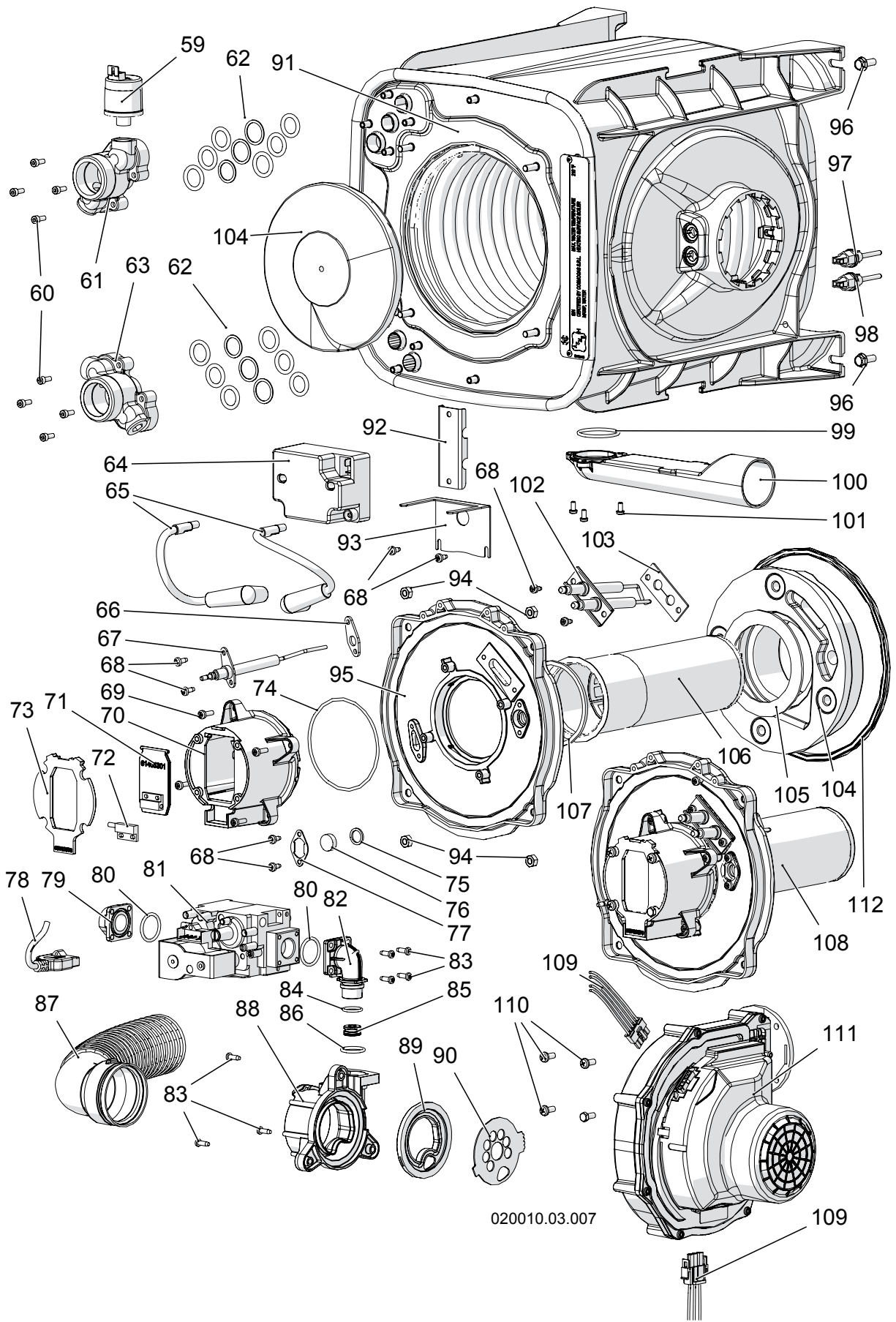

020010.03.007

DESCRIPTION	MOD.	DESCRIPTION	MOD.
BOILER 199	A	WATER HEATER 199	C

N	CODE	DESCRIPTION	MOD
1	60801146	SCREW 6X14 GALVANISED	AC
2	62617330	3" COMPLETE AIR INLET CONNECTION	AC
3	62610091	BLACK UPPER COVER	AC
3	62610098	GREY UPPER COVER	AC
4	60404391	BENT BOX COVER	AC
5	62118037	0-10V INTERFACE 885 120V 2D	AC
6	61103015	PVC CLAMPER INTERNAL DIAM. 22	AC
9	61405347	WATER PROTECTION COVER FAN GROUP	AC
10	60107014	3/4P F BRASS PLUG	AC
11	60701006	GASKET 3/4P 24X15X2 KLINSIL	AC
15	62801023	CONDENSE ACIDITY NEUTRALIZER UNTIL 280 KW BOX	AC
16	60322021	CORRUGATED TUBE DIAM 28 L 1250	AC
17	60805006	ADJUSTABLE FOOT	AC
18	60322020	CORRUGATED TUBE DIAM 28 L 800	AC
19	62801022	NEUTRALISING LIMESTONE 10 KG	AC
20	62612786	REPLACEMENT KIT 885MN10 110 V	AC
21	60502085	SINGLE GREY BOARD CLAMP	AC
21	60502086	ON FLOOR YELLOW-GREEN BOARD CLAMP	AC
21	60502101	SINGLE BLUE BOARD CLAMP	AC
22	60506031	BLACK 2 POLES SWITCH	AC
23	60507059	CONNECTION BOARD 160X100	AC
24	62113046	PRESSURE SWITCH ON 3,2 INWC	AC
25	60703034	GASKET EPDM D.125	AC
26	61405373	D.125 H.703 COLLECTOR-1 EXCHANGER	AC
27	62801021	SYNTHETIC PLATE FILTER	AC
28	62110067	OUTDOOR SENSOR	AC
29	62110071	SENSOR 10K D6X45 L=2500 T	AC
30	62630210	LP-NAT CONV KIT 199 AND 399 RBI	AC
31	62630209	NAT-LP CONV KIT 199-1000 RBI	AC
32	62417021	IB AND IW-RBI 199-1000 USER INSTRUCTION	AC
33	62403588	IB AND IW-RBI 199-1000 INST INSTRUCTION	AC
34	60702097	GASKET D.119 H.18 I.94	AC
35	60702096	GASKET D120.2 H20.5 I92	AC
36	62651066	CONDENSATE BLOCKED DRAIN SWITCH	AC
37	62111051	MAGNETIC SENSOR D5,8X38	AC
38	60320001	SILICONE PIPE D.4X8	AC
39	61405339	RIGHT REDUCED TAP 1/4"-3/8"	AC
40	60702059	EPDM CLAMPER	AC
41	62610094	COMPLETE BLACK FRONT COVER H80	AC
41	62610097	COMPLETE GREY FRONT COVER H80	AC
41	62610094	COMPLETE BLACK FRONT COVER H80	AC
41	62610097	COMPLETE GREY FRONT COVER H80	AC
41	62610097	COMPLETE GREY FRONT COVER H80	AC
41	62610094	COMPLETE BLACK FRONT COVER H80	AC
41	62610097	COMPLETE GREY FRONT COVER H80	AC
42	61405320	NO LOGO FRONT COVER	AC

DESCRIPTION	MOD.	DESCRIPTION	MOD.
BOILER 199	A	WATER HEATER 199	C

N	CODE	DESCRIPTION	MOD
43	61405254	6 BUTTONS SWITCH	AC
44	62110089	DISPLAY TYPE 885LB01	AC
45	61405264	DISPLAY GLASS	AC
46	62610100	ABS 287X600 BASE BLACK	AC
46	62610099	ABS 287X600 BASE GREY	AC
47	61205024	SAFETY VALVE 3/4P M ASME NPT 125 PSI	C
49	62115005	THERMOMANOM. D.80 0-200 PSI 60-320°F	C
52	62111026	CLIP SENSOR NTC 10 KOHM D. 28	AC
55	61212014	VORTEX FLOW SENSOR	AC
57	60701007	1"1/4 GASKET	AC
58	62621154	COPPER TUBE D28 F/F 1'1/4 1'1/4	AC
59	62113045	PRESSURE GAUGE 0-10 BAR	AC
60	60801151	SCREW 4X10 GALVANIZED	AC
61	61408014	BRASS CONNECTION 1"1/4 SUPPLY	AC
62	62616111	KIT FOR 6 OR AND 3 WASHERS	AC
63	61408013	BRASS CONNECTION 1"1/4 RETURN	AC
64	60510022	SPARK GENERATOR	AC
65	60504206	CABLE UL IGNITOR CONN 90° L155	AC
66	60701023	GASKET KERASIL 325R SQ 38X17X2	AC
67	62632007	GRP DETECTION ELECTRODE	AC
68	60801081	SELFTAPPING SCREW 4X8 TC S-TT UNI-8112	AC
69	60801108	SELFTAPPING SCREW 4X14 TCC-NP UNI-8112	AC
70	61404123	AXIAL FAN COLLECTOR H.69	AC
71	62651043	MAGNET CLAP GROUP	AC
72	62111044	REED MAGNETIC POSITION SENSOR	AC
73	60702078	GASKET SHAPED FOR FAN	AC
74	60702077	OR RING 3325 SIL 2,62 X 82,22	AC
75	60701013	GASKET FRIZITE D15,5 F11,5 SP1,5	AC
76	60815013	PIREX GLASS D15,5 SP5	AC
77	60404253	FLANGE L21,2 H34 SP1	AC
78	60504266	MASTER GAS CABLE UL 885	AC
79	60101224	FLANGE GAS 32X32 3/4P	AC
80	60702029	O-RING 130 2,62 X 22,22	AC
81	62632024	GRP SPARE GAS VALVE USA	AC
82	61404121	90° INTERNAL ELBOW	AC
83	60801136	SCREW SELFTAPPING 4X12 TC S-TT UNI-8112	AC
84	60702052	O-RING 2050 EPDM 1,78 X 12,42	AC
85	60114093	GAS DIAPHRAGM D.15,5 H8 HOLE D.7	AC
86	60702065	O-RING 2,62 X 17,86	AC
87	62651054	HIGH POWER SILENCER GROUP	AC
88	61404120	COSMOMIX GAS MIXER	AC
89	60702064	SHAPED GASKET DIAM. 71,2 H. 9,2	AC
90	60406142	AIR MIXER DIAPHRAGM 7 D.10-1 D.17	AC
91	62649053	CONDENSING HEAT EXCHANGER 58KW 12T ASME H	AC
91	62649050	CONDENSING HEAT EXCHANGER 58KW 12T ASME HLW	C
92	60434036	EXCHANGERS BRACKET	AC

DESCRIPTION	MOD.	DESCRIPTION	MOD.
BOILER 199	A	WATER HEATER 199	C

N	CODE	DESCRIPTION	MOD
93	60406137	SHAPED BRACKET 67X54X36	AC
94	60802005	NUT ZINC COATED 6MA	AC
95	61404122	FAN COLLECTOR BASE	AC
96	60801093	SCREW 6X16 8.8 WITH WASHER UNI 6921	AC
97	62111041	BAYONETTE SENSOR NTC 10K 2P MOLEX	AC
98	62111042	BAYONETTE FUSE 102°C 2P MOLEX	AC
99	60702083	OR RING 3137 EPDM 2,62 X 34,60	AC
100	61405300	CONDENSATION DISCHARGE PIPE D.46.7	AC
101	60801138	SCREW 4X8 ZINC TC-CR DIN4042	AC
102	62632008	GRP IGNITION ELECTRODE	AC
103	60701022	GASKET KERASIL 325R SQ 56X22X2	AC
104	62632006	KIT THERMAL INSULATIONS	AC
105	60701021	GASKET S.WOLL PLUS D.100 SP.2	AC
106	62629045	FIBER BURNER D.70 H200	AC
107	60701019	KERASIL GASKET 325R SQ Ø 80.5 MM	AC
108	62651052	AXIAL BURNER GROUP 58-70KW	AC
109	60504265	FAN CABLE UL 885	AC
110	60801021	BOLT 5X12 CROSS HEAD	AC
111	61901036	BOILER FAN 135 KW 115V	AC
112	60703047	SIL. GASKET D.200 F.188 H.7,2	AC
113	60503064	RELAY 115V 16A EXCHANGE	AC
114	60503026	FUSE 3A DELAYED GLASS	AC
115	60503065	FUSE 10 A DELAYED GLASS	AC
116	61405348	CONICAL PLUG TAB D.29.2-32,7	AC
117	62617355	CONNECTION STAIN 3P PVC H252MM	AC
118	62111052	FLOAT D40X16X8,6	AC
119	60801106	SCREW 6X25 GALVANIZED	AC
120	62101079	AUTOMATIC SAFETY THERMOSTAT 95°C	AC
121	60702085	POLY PROP EXHAUST GASKET 170X170	AC
122	60338042	GAS COLLECTOR 1P NPT 4 HOLE FLANGE	AC
123	62626008	GAS VALVE PIPE	AC
124	62621151	COPPER TUBE D28 F/F 1'1/4 H=550	AC
125	60807002	SPRING FOR 3/4" RING NUT	AC
126	60108006	SENSOR TRAP	AC
127	61206002	AIR VENT VALVE	AC
128	60101072	BRASS REDUCTION 3/8 INCH	AC
129	61204005	SCREWDRIVER 1/2" CHARGE FAUCET	AC
130	60107020	1P1/4 F BRASS PLUG	AC
131	60338036	SUP/RET COLLECTOR 2P NPT CARB	A
131	60338033	SUP/RET COLLECTOR 2P NPT INOX	C
132	60801065	6X12MM TC CR SCREW	AC
133	60113009	BRASS CONNECTION 1P1/4 - 1P1/4	AC
134	62621187	COPPER TUBE D28 F/F 1'1/4 1'1/4 NO VALV	AC

Spare parts for models:

399

500

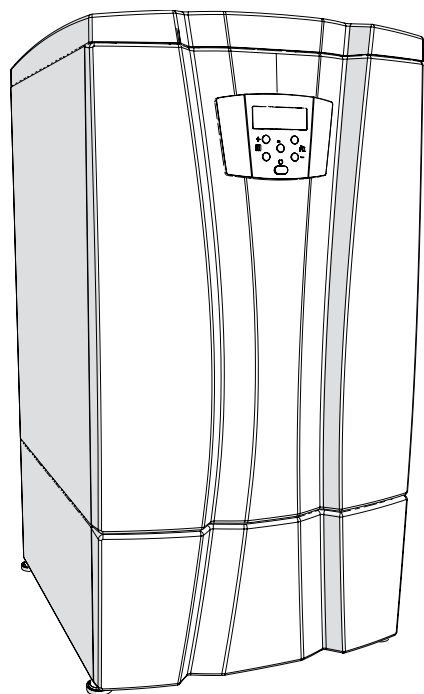

DESCRIPTION	MOD	DESCRIPTION	MOD
BOILER 399	A	WATER HEATER 399	C
BOILER 500	B	WATER HEATER 500	D

WARNING!!! Only use the heater in combinations and with the spare parts listed in this manual. Failure to do so can cause severe personal injury or death.

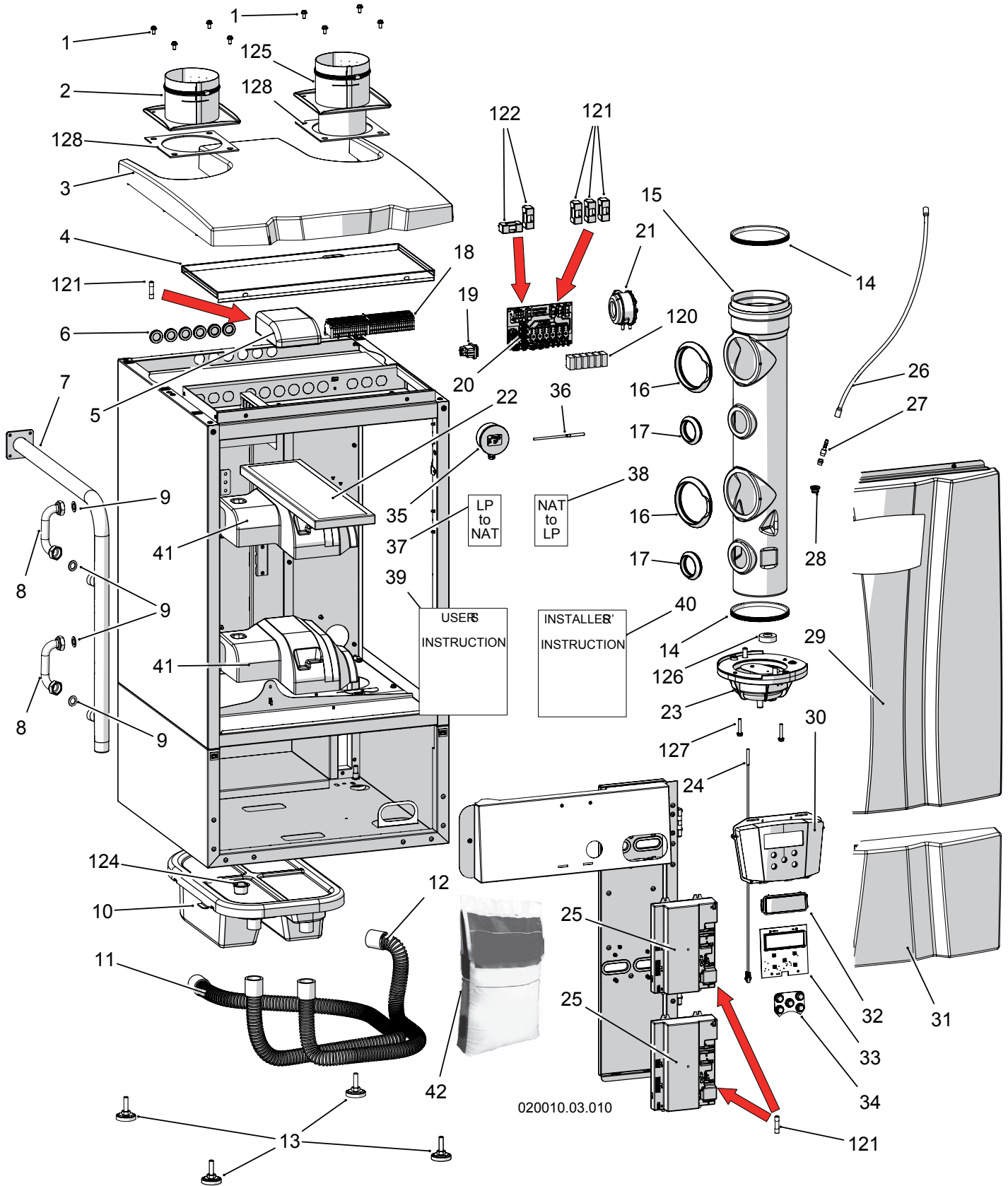

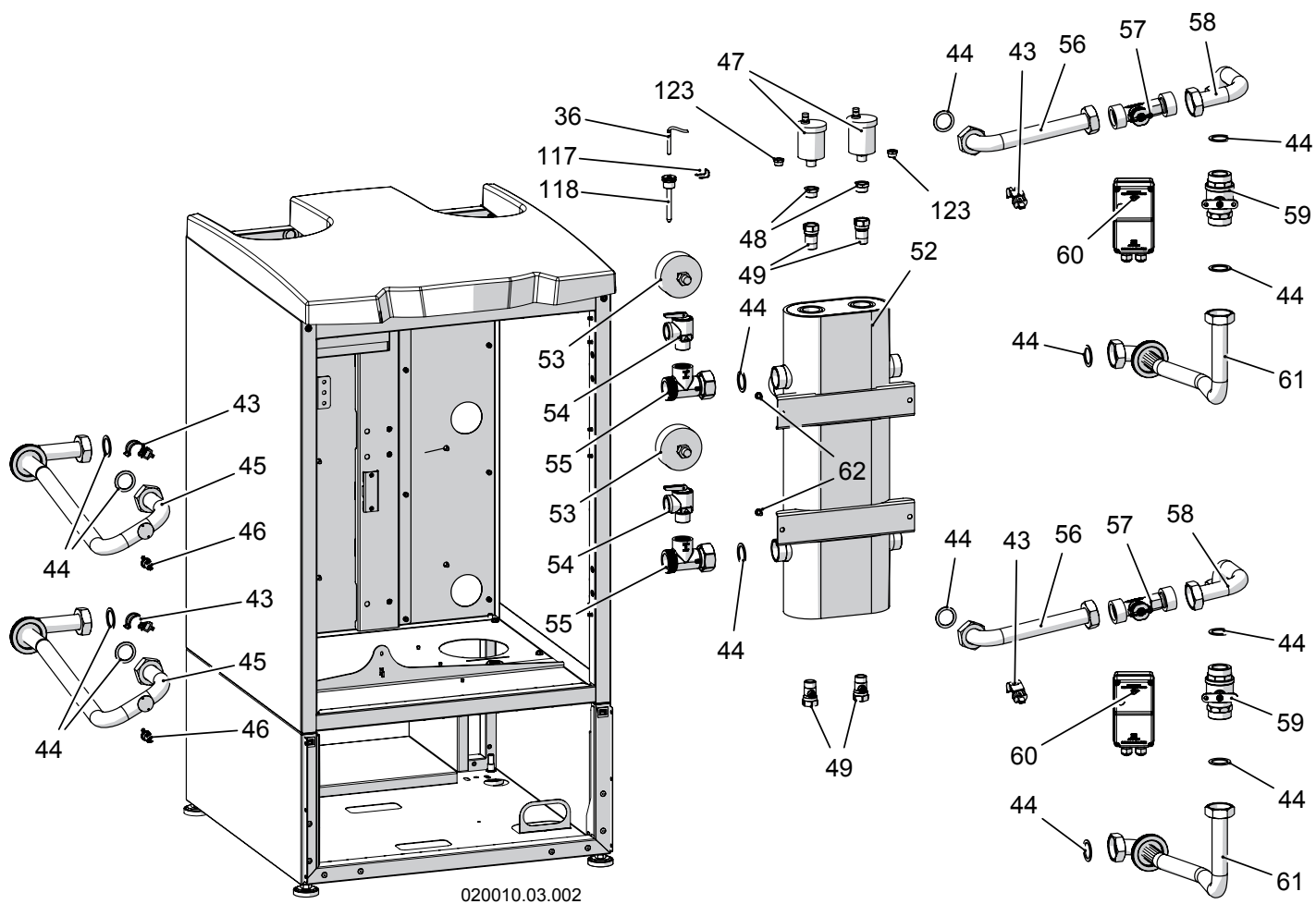

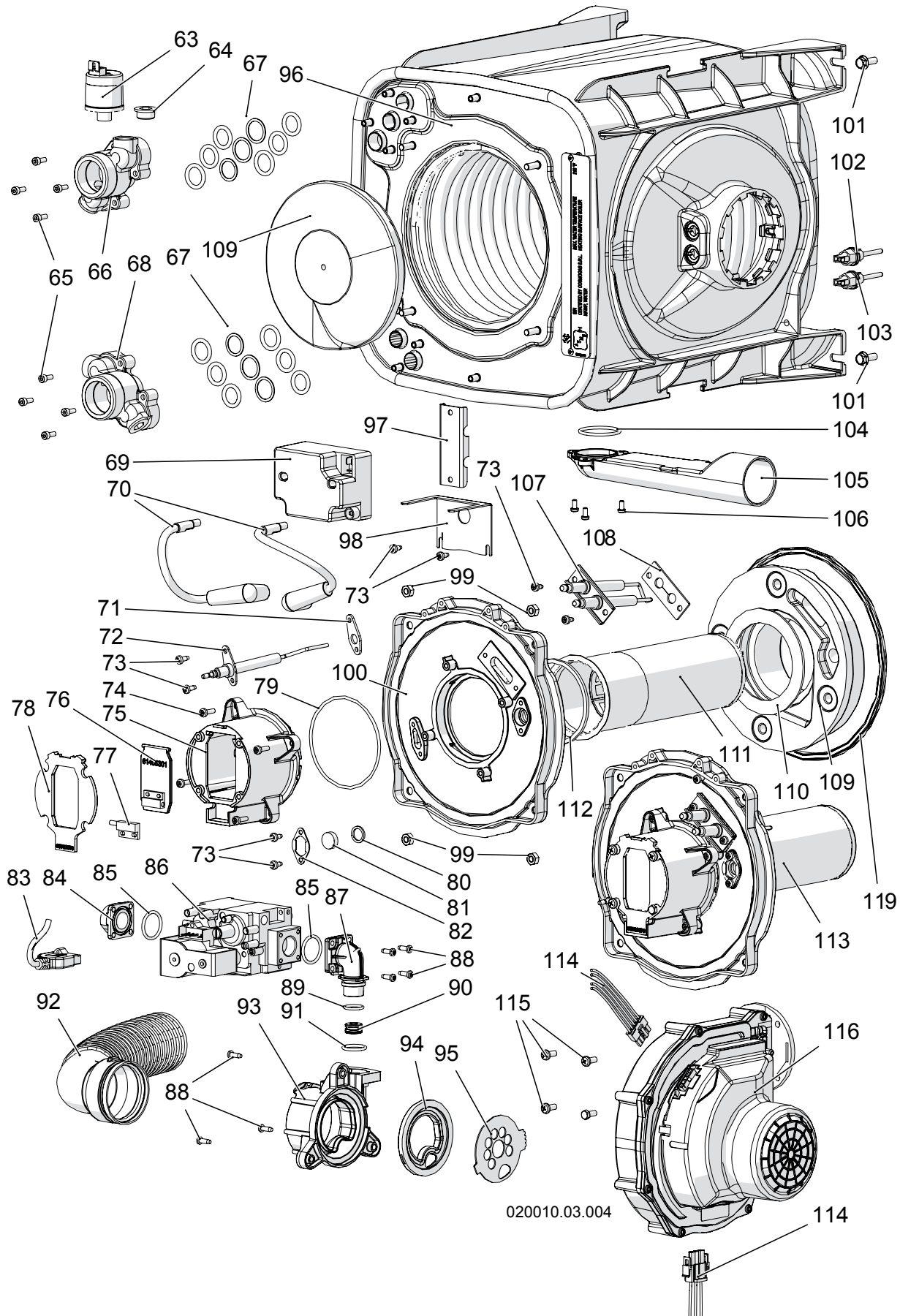

020010.03.004

19 - SPARE PARTS

399 to 500

DESCRIPTION	MOD.	DESCRIPTION	MOD.	DESCRIPTION	MOD.
BOILER 399	A	WATER HEATER 399	C	ALL MODELS WITH MOTORIZED VALVE	E
BOILER 500	B	WATER HEATER 500	D	ALL MODELS WITHOUT MOTORIZED VALVE	F

N	CODE	DESCRIPTION	MOD
1	60801146	SCREW 6X14 GALVANISED	ABCD
2	62617327	4" COMPLETE AIR INLET CONNECTION	ABCD
3	62610091	BLACK UPPER COVER	ABCD
3	62610098	GREY UPPER COVER	ABCD
4	60404391	BENT BOX COVER	ABCD
5	62118037	0-10V INTERFACE 885 120V 2D	ABCD
6	61103015	PVC CLAMPER INTERNAL DIAM. 22	ABCD
7	60338042	GAS COLLECTOR 1P NPT 4 HOLE FLANGE	ABCD
8	62626008	GAS VALVE PIPE	ABCD
9	60701006	GASKET 3/4P 24X15X2 KLINSIL	ABCD
10	62801023	CONDENSE ACIDITY NEUTRALIZER UNTIL 280 KW BOX	ABCD
11	60322021	CORRUGATED TUBE DIAM 28 L 1250	ABCD
12	60322020	CORRUGATED TUBE DIAM 28 L 800	ABCD
13	60805006	ADJUSTABLE FOOT	ABCD
14	60703034	GASKET EPDM D.125	ABCD
15	61405374	D.125 H.703 COLLECTOR-2 EXCHANGERS	ABCD
16	60702097	GASKET D.119 H.18 I.94	ABCD
17	60702096	GASKET D120.2 H20.5 I92	ABCD
18	60502085	SINGLE GREY BOARD CLAMP	ABCD
18	60502086	ON FLOOR YELLOW-GREEN BOARD CLAMP	ABCD
18	60502101	SINGLE BLUE BOARD CLAMP	ABCD
19	60506031	BLACK 2 POLES SWITCH	ABCD
20	60507059	CONNECTION BOARD 160X100	ABCD
21	62113046	PRESSURE SWITCH ON 3,2 INWC	ABCD
22	62801021	SYNTHETIC PLATE FILTER	ABCD
23	62651066	CONDENSATE BLOCKED DRAIN SWITCH	ABCD
24	62111051	MAGNETIC SENSOR D5,8X38	ABCD
25	62612786	REPLACEMENT KIT 885MN10 110 V	ABCD
26	60320001	SILICONE PIPE D.4X8	ABCD
27	61405339	RIGHT REDUCED TAP 1/4"-3/8"	ABCD
28	60702059	EPDM CLAMPER	ABCD
29	62610094	COMPLETE BLACK FRONT COVER H80	ABCD
29	62610097	COMPLETE GREY FRONT COVER H80	ABCD
30	61405320	NO LOGO FRONT COVER	ABCD
31	62610100	ABS 287X600 BASE BLACK	ABCD
31	62610099	ABS 287X600 BASE GREY	ABCD
32	61405264	DISPLAY GLASS	ABCD
33	62110089	DISPLAY TYPE 885LB01	ABCD
34	61405254	6 BUTTONS SWITCH	ABCD
35	62110067	OUTDOOR SENSOR	ABCD
36	62110071	SENSOR 10K D6X45 L=2500 T	ABCD
37	62630210	LP-NAT CONV KIT 199 AND 399 RBI	AC
37	62630211	LP-NAT CONV KIT 500-750-1000 RBI	BD
38	62630209	NAT-LP CONV KIT 199-1000 RBI	ABCD
39	62417021	IB AND IW-RBI 199-1000 USER INSTRUCTION	ABCD
40	62403588	IB AND IW-RBI 199-1000 INST INSTRUCTION	ABCD
41	61405347	WATER PROTECTION COVER FAN GROUP	ABCD

19 - SPARE PARTS

399 to 500

DESCRIPTION	MOD.	DESCRIPTION	MOD.	DESCRIPTION	MOD.
BOILER 399	A	WATER HEATER 399	C	ALL MODELS WITH MOTORIZED VALVE	E
BOILER 500	B	WATER HEATER 500	D	ALL MODELS WITHOUT MOTORIZED VALVE	F

N	CODE	DESCRIPTION	MOD
42	62801022	NEUTRALISING LIMESTONE 10 KG	ABCD
43	62111026	CLIP SENSOR NTC 10 KOHM D. 28	ABCD
44	60701007	1"1/4 GASKET	ABCD
45	62621151	COPPER TUBE D28 F/F 1'1/4 H=550	ABCD
46	62101079	AUTOMATIC SAFETY THERMOSTAT 95°C	ABCD
47	61206002	AIR VENT VALVE	ABCD
48	60101072	BRASS REDUCTION 3/8 INCH	ABCD
49	61204005	SCREWDRIVER 1/2" CHARGE FAUCET	ABCD
52	60338033	SUP/RET COLLECTOR 2P NPT INOX	ABCD
52	60338036	SUP/RET COLLECTOR 2P NPT CARB	AB
53	62115005	THERMOMANOM. D.80 0-200 PSI 60-320°F	CD
54	61205024	SAFETY VALVE 3/4P M ASME NPT 125 PSI	CD
55	60113009	BRASS CONNECTION 1P1/4 - 1P1/4	ABCD
56	62621154	COPPER TUBE D28 F/F 1'1/4 1'1/4	ABCD
57	61212014	VORTEX FLOW SENSOR	ABCD
58	62621153	COPPER TUBE D28 F/F 1'1/4 1'1/4 RIT 2	E
58	62621187	COPPER TUBE D28 F/F 1'1/4 1'1/4 NO VALV	F
59	61202043	SPHERE 2 WAY VALVE	E
60	61203024	2 WAY VALVE MOTOR	E
61	62621152	COPPER TUBE D28 F/F 1'1/4 1'1/4 RIT	E
62	60801065	6X12MM TC CR SCREW	ABCD
63	62113045	PRESSURE GAUGE 0-10 BAR	ABCD
64	60107005	PLUG BRASS 1/4P M WITH O-RING	ABCD
65	60801151	SCREW 4X10 GALVANIZED	ABCD
66	61408014	BRASS CONNECTION 1"1/4 SUPPLY	ABCD
67	62616111	KIT FOR 6 OR AND 3 WASHERS	ABCD
68	61408013	BRASS CONNECTION 1"1/4 RETURN	ABCD
69	60510022	SPARK GENERATOR	ABCD
70	60504206	CABLE UL IGNITOR CONN 90° L155	ABCD
71	60701023	GASKET KERASIL 325R SQ 38X17X2	ABCD
72	62632007	GRP DETECTION ELECTRODE	ABCD
73	60801081	SELFTAPPING SCREW 4X8 TC S-TT UNI-8112	ABCD
74	60801108	SELFTAPPING SCREW 4X14 TCC-NP UNI-8112	ABCD
75	61404123	AXIAL FAN COLLECTOR H.69	ABCD
76	62651043	MAGNET CLAP GROUP	ABCD
77	62111044	REED MAGNETIC POSITION SENSOR	ABCD
78	60702078	GASKET SHAPED FOR FAN	ABCD
79	60702077	OR RING 3325 SIL 2,62 X 82,22	ABCD
80	60701013	GASKET FRIZITE D15,5 F11,5 SP1,5	ABCD
81	60815013	PIREX GLASS D15,5 SP5	ABCD
82	60404253	FLANGE L21,2 H34 SP1	ABCD
83	60504266	MASTER GAS CABLE UL 885	ABCD
83	60504267	SLAVE GAS CABLE UL 885	ABCD
84	60101224	FLANGE GAS 32X32 3/4P	ABCD
85	60702029	O-RING 130 2,62 X 22,22	ABCD
86	62632024	GRP SPARE GAS VALVE USA	ABCD
87	61404121	90° INTERNAL ELBOW	ABCD

19 - SPARE PARTS

399 to 500

DESCRIPTION	MOD.	DESCRIPTION	MOD.	DESCRIPTION	MOD.
BOILER 399	A	WATER HEATER 399	C	ALL MODELS WITH MOTORIZED VALVE	E
BOILER 500	B	WATER HEATER 500	D	ALL MODELS WITHOUT MOTORIZED VALVE	F

N	CODE	DESCRIPTION	MOD
88	60801136	SCREW SELFTAPPING 4X12 TC S-TT UNI-8112	ABCD
89	60702052	O-RING 2050 EPDM 1,78 X 12,42	ABCD
90	60114093	GAS DIAPHRAGM D.15,5 H8 HOLE D.7	ABCD
90	60114100	GAS DIAPHRAGM D.15,5 H8 HOLE D.9,3	BD
91	60702065	O-RING 2,62 X 17,86	ABCD
92	62651054	HIGH POWER SILENCER GROUP	ABCD
93	61404120	COSMOMIX GAS MIXER	ABCD
94	60702064	SHAPED GASKET DIAM. 71,2 H. 9,2	ABCD
95	60406142	AIR MIXER DIAPHRAGM 7 D.10-1 D.17	ABCD
96	62649053	CONDENSING HEAT EXCHANGER 58KW 12T ASME H	AC
96	62649050	CONDENSING HEAT EXCHANGER 58KW 12T ASME HLW	C
96	62649018	CONDENSING HEAT EXCHANGER 70KW 15T ASME H	BD
96	62649051	CONDENSING HEAT EXCHANGER 70KW 15T ASME HLW	D
97	60434036	EXCHANGERS BRACKET	ABCD
98	60406137	SHAPED BRACKET 67X54X36	ABCD
99	60802005	NUT ZINC COATED 6MA	ABCD
100	61404122	FAN COLLECTOR BASE	ABCD
101	60801093	SCREW 6X16 8.8 WITH WASHER UNI 6921	ABCD
102	62111041	BAYONETTE SENSOR NTC 10K 2P MOLEX	ABCD
103	62111042	BAYONETTE FUSE 102°C 2P MOLEX	ABCD
104	60702083	OR RING 3137 EPDM 2,62 X 34,60	ABCD
105	61405300	CONDENSATION DISCHARGE PIPE D.46.7	ABCD
106	60801138	SCREW 4X8 ZINC TC-CR DIN4042	ABCD
107	62632008	GRP IGNITION ELECTRODE	ABCD
108	60701022	GASKET KERASIL 325R SQ 56X22X2	ABCD
109	62632006	KIT THERMAL INSULATIONS	ABCD
110	60701021	GASKET S.WOLL PLUS D.100 SP.2	ABCD
111	62629045	FIBER BURNER D.70 H200	ABCD
112	60701019	KERASIL GASKET 325R SQ Ø 80.5 MM	ABCD
113	62651052	AXIAL BURNER GROUP 58-70KW	ABCD
114	60504265	FAN CABLE UL 885	ABCD
115	60801021	BOLT 5X12 CROSS HEAD	ABCD
116	61901036	BOILER FAN 135 KW 115V	ABCD
117	60807002	SPRING FOR 3/4" RING NUT	ABCD
118	60108006	SENSOR TRAP	ABCD
119	60703047	SIL. GASKET D.200 F.188 H.7,2	ABCD
120	60503064	RELAY 115V 16A EXCHANGE	ABCD
121	60503026	FUSE 3A DELAYED GLASS	ABCD
122	60503065	FUSE 10 A DELAYED GLASS	ABCD
123	60101119	3/8G MALE TO 1/8NPT FEMALE BUSHING	ABCD
124	61405348	CONICAL PLUG TAB D.29.2-32,7	ABCD
125	62617353	CONNECTION STAIN 4P PVC H252MM	ABCD
126	62111052	FLOAT D40X16X8,6	ABCD
127	60801106	SCREW 6X25 GALVANIZED	ABCD
128	60702085	POLY PROP EXHAUST GASKET 170X170	ABCD

Spare parts for gas-fired condensing hot water heaters series:

750
1000

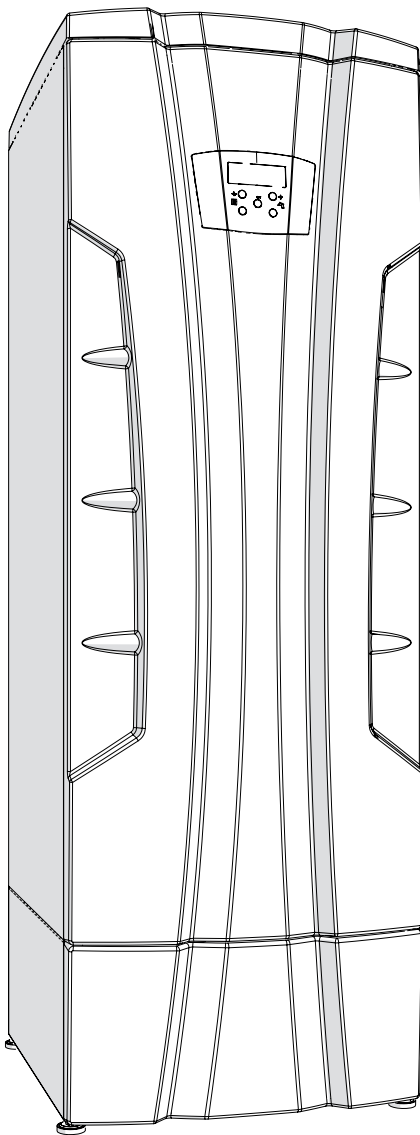

DESCRIPTION	MOD	DESCRIPTION	MOD
BOILER 750	A	WATER HEATER 750	C
BOILER 1000	B	WATER HEATER 1000	D

WARNING!!! Only use the heater in the combinations and with the spare parts listed in this manual. Failure to do so can cause severe personal injury or death.

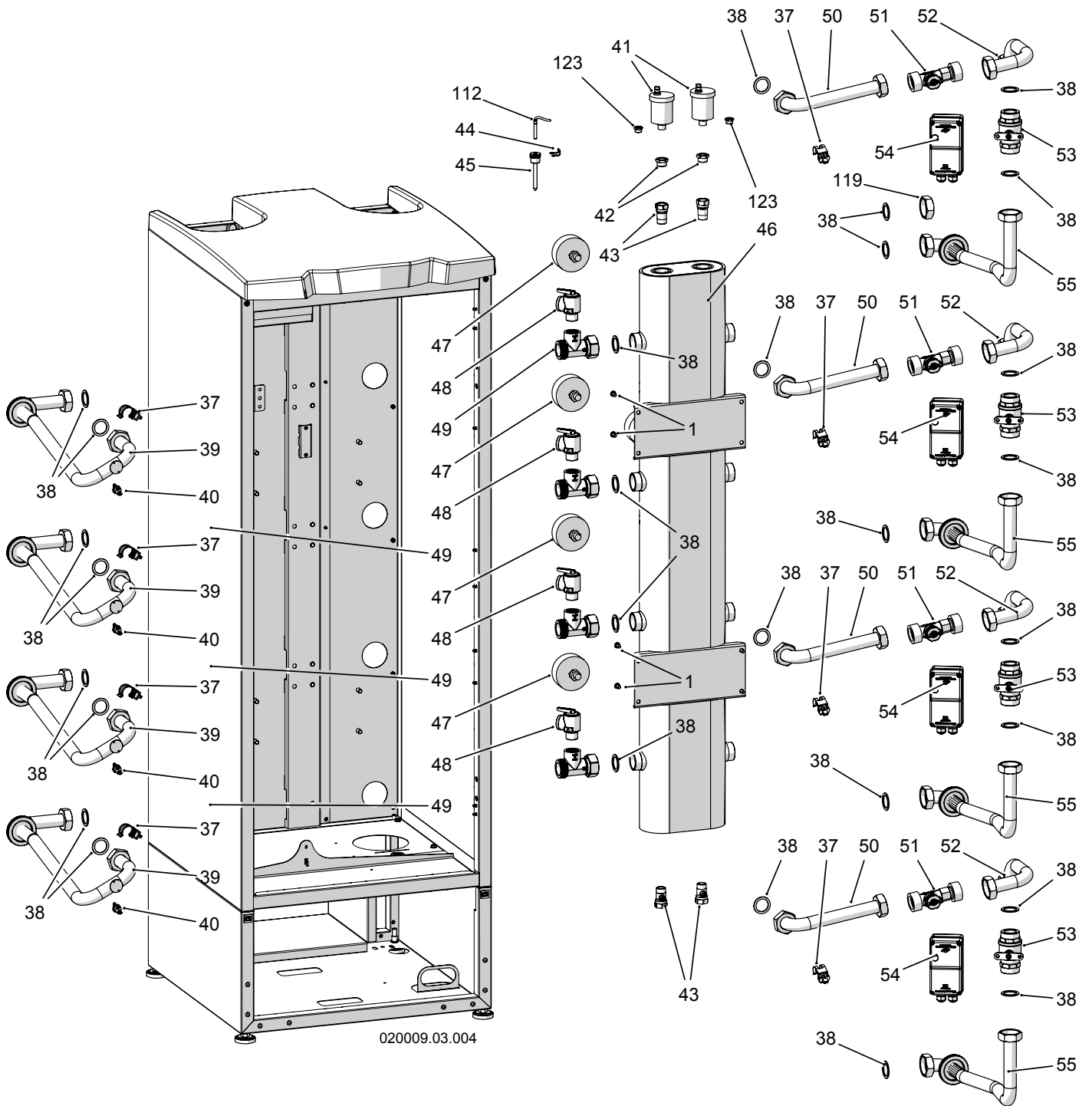

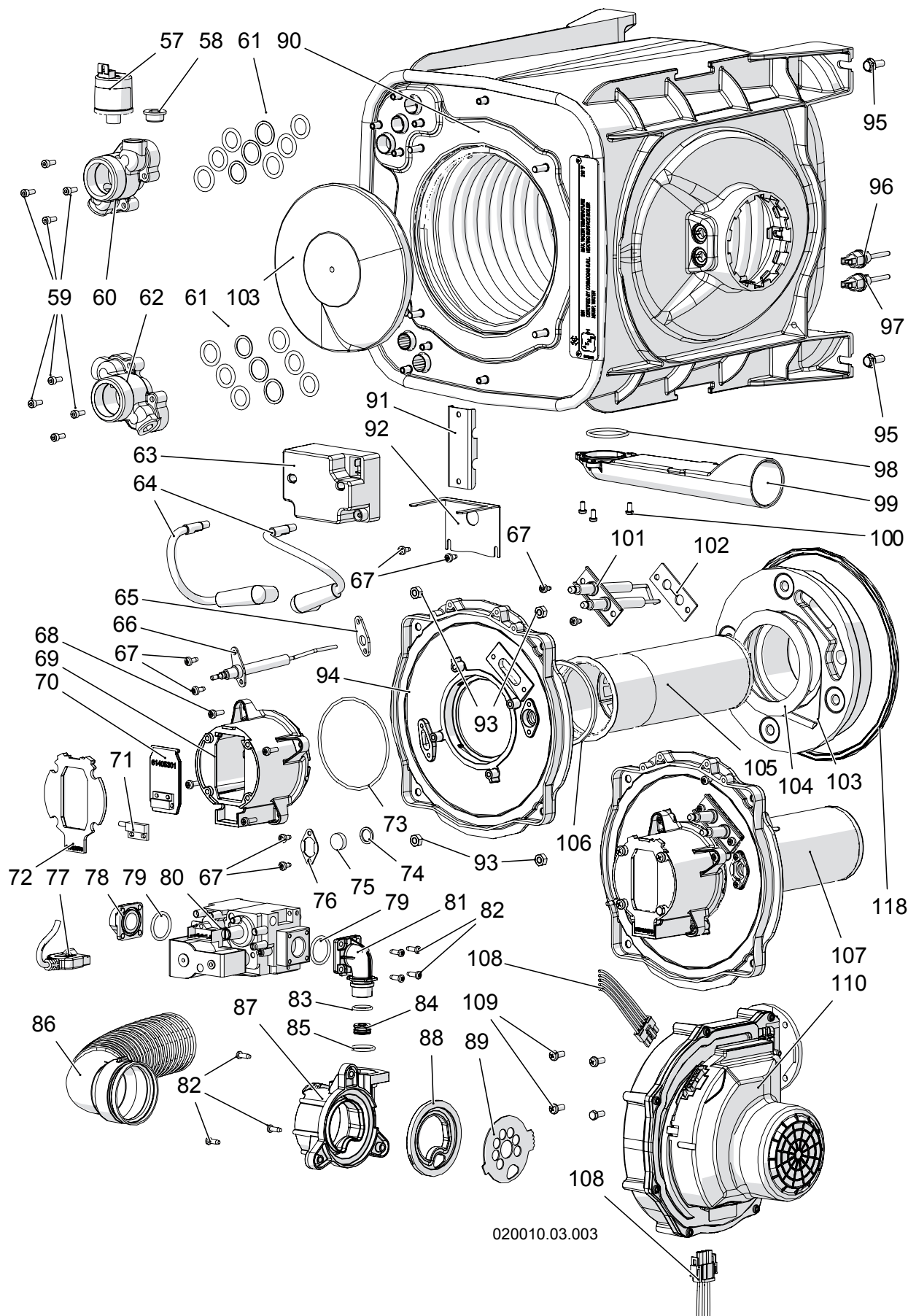

19 - SPARE PARTS

750 and 1000

DESCRIPTION	MOD.	DESCRIPTION	MOD.	DESCRIPTION	MOD.
BOILER 750	A	WATER HEATER 750	C	ALL MODELS WITH MOTORIZED VALVE	E
BOILER 1000	B	WATER HEATER 1000	D	ALL MODELS WITHOUT MOTORIZED VALVE	F

N	CODE	DESCRIPTION	MOD
1	60801146	SCREW 6X14 GALVANISED	ABCD
2	62617326	6" COMPLETE AIR INLET CONNECTION	ABCD
3	62610091	BLACK UPPER COVER	ABCD
3	62610098	GREY UPPER COVER	ABCD
4	60404391	BENT BOX COVER	ABCD
5	62118037	0-10V INTERFACE 885 120V 2D	ABCD
6	61103015	PVC CLAMPER INTERNAL DIAM. 22	ABCD
7	60338046	COLLECTOR GAS 1P 1/4 NPT FLANGE 4 HOLES	ABCD
8	62626008	GAS VALVE PIPE	ABCD
9	60701006	GASKET 3/4P 24X15X2 KLINSIL	ABCD
10	62801023	CONDENSE ACIDITY NEUTRALIZER UNTIL 280 KW BOX	ABCD
11	60322021	CORRUGATED TUBE DIAM 28 L 1250	ABCD
12	60322020	CORRUGATED TUBE DIAM 28 L 800	ABCD
13	60805006	ADJUSTABLE FOOT	ABCD
14	60703034	GASKET EPDM D.125	ABCD
15	61405373	D.125 H.703 COLLECTOR-1 EXCHANGER	AC
15	61405374	D.125 H.703 COLLECTOR-2 EXCHANGERS	ABCD
16	60702097	GASKET D.119 H.18 I.94	ABCD
17	60702096	GASKET D120.2 H20.5 I92	ABCD
18	60502085	SINGLE GREY BOARD CLAMP	ABCD
18	60502086	ON FLOOR YELLOW-GREEN BOARD CLAMP	ABCD
18	60502101	SINGLE BLUE BOARD CLAMP	ABCD
19	60506031	BLACK 2 POLES SWITCH	ABCD
20	60507059	CONNECTION BOARD 160X100	ABCD
21	62113046	PRESSURE SWITCH ON 3,2 INWC	ABCD
22	62801021	SYNTHETIC PLATE FILTER	ABCD
23	62651066	CONDENSATE BLOCKED DRAIN SWITCH	ABCD
24	62111051	MAGNETIC SENSOR D5,8X38	ABCD
25	62612786	REPLACEMENT KIT 885MN10 110 V	ABCD
26	60320001	SILICONE PIPE D.4X8	ABCD
27	61405339	RIGHT REDUCED TAP 1/4"-3/8"	ABCD
28	60702059	EPDM CLAMPER	ABCD
29	62610093	COMPLETE PLASTIC FRONT COVER BLACK	ABCD
29	62610096	COMPLETE PLASTIC FRONT COVER GREY	ABCD
30	62111052	FLOAT D40X16X8,6	ABCD
31	61405320	NO LOGO FRONT COVER	ABCD
32	62610100	ABS 287X600 BASE BLACK	ABCD
32	62610099	ABS 287X600 BASE GREY	ABCD
33	61405264	DISPLAY GLASS	ABCD
34	62110089	DISPLAY TYPE 885LB01	ABCD
35	61405254	6 BUTTONS SWITCH	ABCD
36	61405347	WATER PROTECTION COVER FAN GROUP	ABCD
37	62111026	CLIP SENSOR NTC 10 KOHM D. 28	ABCD
38	60701007	1"1/4 GASKET	ABCD
39	62621151	COPPER TUBE D28 F/F 1"1/4 H=550	ABCD
40	62101079	AUTOMATIC SAFETY THERMOSTAT 95°C	ABCD

19 - SPARE PARTS

750 and 1000

DESCRIPTION	MOD.	DESCRIPTION	MOD.	DESCRIPTION	MOD.
BOILER 750	A	WATER HEATER 750	C	ALL MODELS WITH MOTORIZED VALVE	E
BOILER 1000	B	WATER HEATER 1000	D	ALL MODELS WITHOUT MOTORIZED VALVE	F

N	CODE	DESCRIPTION	MOD
41	61206002	AIR VENT VALVE	ABCD
42	60101072	BRASS REDUCTION 3/8 INCH	ABCD
43	61204005	SCREWDRIVER 1/2" CHARGE FAUCET	ABCD
44	60807002	SPRING FOR 3/4" RING NUT	ABCD
45	60108006	SENSOR TRAP	ABCD
46	60338028	SUP/RET COLLECTOR 2P1/2 NPT INOX	ABCD
46	60338024	SUP/RET COLLECTOR 2P1/2 NPT CARB	AB
47	62115005	THERMOMANOM. D.80 0-200 PSI 60-320°F	CD
48	61205024	SAFETY VALVE 3/4P M ASME NPT 125 PSI	CD
49	60113009	BRASS CONNECTION 1P1/4 - 1P1/4	ABCD
50	62621154	COPPER TUBE D28 F/F 1'1/4 1'1/4	ABCD
51	61212014	VORTEX FLOW SENSOR	ABCD
52	62621153	COPPER TUBE D28 F/F 1'1/4 1'1/4 RIT 2	E
52	62621187	COPPER TUBE D28 F/F 1'1/4 1'1/4 NO VALV	F
53	61202043	SPHERE 2 WAY VALVE	E
54	61203024	2 WAY VALVE MOTOR	E
55	62621152	COPPER TUBE D28 F/F 1'1/4 1'1/4 RIT	E
56	60801106	SCREW 6X25 GALVANIZED	ABCD
57	62113045	PRESSURE GAUGE 0-10 BAR	ABCD
58	60107005	PLUG BRASS 1/4P M WITH O-RING	ABCD
59	60801151	SCREW 4X10 GALVANIZED	ABCD
60	61408014	BRASS CONNECTION 1"1/4 SUPPLY	ABCD
61	62616111	KIT FOR 6 OR AND 3 WASHERS	ABCD
62	61408013	BRASS CONNECTION 1"1/4 RETURN	ABCD
63	60510022	SPARK GENERATOR	ABCD
64	60504206	CABLE UL IGNITOR CONN 90° L155	ABCD
65	60701023	GASKET KERASIL 325R SQ 38X17X2	ABCD
66	62632007	GRP DETECTION ELECTRODE	ABCD
67	60801081	SELFTAPPING SCREW 4X8 TC S-TT UNI-8112	ABCD
68	60801108	SELFTAPPING SCREW 4X14 TCC-NP UNI-8112	ABCD
69	61404123	AXIAL FAN COLLECTOR H.69	ABCD
70	62651043	MAGNET CLAP GROUP	ABCD
71	62111044	REED MAGNETIC POSITION SENSOR	ABCD
72	60702078	GASKET SHAPED FOR FAN	ABCD
73	60702077	OR RING 3325 SIL 2,62 X 82,22	ABCD
74	60701013	GASKET FRIZITE D15,5 F11,5 SP1,5	ABCD
75	60815013	PIREX GLASS D15,5 SP5	ABCD
76	60404253	FLANGE L21,2 H34 SP1	ABCD
77	60504266	MASTER GAS CABLE UL 885	ABCD
77	60504267	SLAVE GAS CABLE UL 885	ABCD
78	60101224	FLANGE GAS 32X32 3/4P	ABCD
79	60702029	O-RING 130 2,62 X 22,22	ABCD
80	62632024	GRP SPARE GAS VALVE USA	ABCD
81	61404121	90° INTERNAL ELBOW	ABCD
82	60801136	SCREW SELFTAPPING 4X12 TC S-TT UNI-8112	ABCD
83	60702052	O-RING 2050 EPDM 1,78 X 12,42	ABCD

19 - SPARE PARTS

750 and 1000

DESCRIPTION	MOD.	DESCRIPTION	MOD.	DESCRIPTION	MOD.
BOILER 750	A	WATER HEATER 750	C	ALL MODELS WITH MOTORIZED VALVE	E
BOILER 1000	B	WATER HEATER 1000	D	ALL MODELS WITHOUT MOTORIZED VALVE	F

N	CODE	DESCRIPTION	MOD
84	60114093	GAS DIAPHRAGM D.15,5 H8 HOLE D.7	ABCD
84	60114100	GAS DIAPHRAGM D.15,5 H8 HOLE D.9,3	ABCD
85	60702065	O-RING 2,62 X 17,86	ABCD
86	62651054	HIGH POWER SILENCER GROUP	ABCD
87	61404120	COSMOMIX GAS MIXER	ABCD
88	60702064	SHAPED GASKET DIAM. 71,2 H. 9,2	ABCD
89	60406142	AIR MIXER DIAPHRAGM 7 D.10-1 D.17	ABCD
90	62649018	CONDENSING HEAT EXCHANGER 70KW 15T ASME H	ABCD
90	62649051	CONDENSING HEAT EXCHANGER 70KW 15T ASME HLW	CD
91	60434036	EXCHANGERS BRACKET	ABCD
92	60406137	SHAPED BRACKET 67X54X36	ABCD
93	60802005	NUT ZINC COATED 6MA	ABCD
94	61404122	FAN COLLECTOR BASE	ABCD
95	60801093	SCREW 6X16 8.8 WITH WASHER UNI 6921	ABCD
96	62111041	BAYONETTE SENSOR NTC 10K 2P MOLEX	ABCD
97	62111042	BAYONETTE FUSE 102°C 2P MOLEX	ABCD
98	60702083	OR RING 3137 EPDM 2,62 X 34,60	ABCD
99	61405300	CONDENSATION DISCHARGE PIPE D.46.7	ABCD
100	60801138	SCREW 4X8 ZINC TC-CR DIN4042	ABCD
101	62632008	GRP IGNITION ELECTRODE	ABCD
102	60701022	GASKET KERASIL 325R SQ 56X22X2	ABCD
103	62632006	KIT THERMAL INSULATIONS	ABCD
104	60701021	GASKET S.WOLL PLUS D.100 SP.2	ABCD
105	62629045	FIBER BURNER D.70 H200	ABCD
106	60701019	KERASIL GASKET 325R SQ Ø 80.5 MM	ABCD
107	62651052	AXIAL BURNER GROUP 58-70KW	ABCD
108	60504265	FAN CABLE UL 885	ABCD
109	60801021	BOLT 5X12 CROSS HEAD	ABCD
110	61901036	BOILER FAN 135 KW 115V	ABCD
111	62110067	OUTDOOR SENSOR	ABCD
112	62110071	SENSOR 10K D6X45 L=2500 T	ABCD
113	62630211	LP-NAT CONV KIT 500-750-1000 RBI	ABCD
114	62630209	NAT-LP CONV KIT 199-1000 RBI	ABCD
115	62417021	IB AND IW-RBI 199-1000 USER INSTRUCTION	ABCD
116	62403588	IB AND IW-RBI 199-1000 INST INSTRUCTION	ABCD
117	62801022	NEUTRALISING LIMESTONE 10 KG	ABCD
118	60703047	SIL. GASKET D.200 F.188 H.7,2	ABCD
119	60107020	1P1/4 F BRASS PLUG	AC
120	60503064	RELAY 115V 16A EXCHANGE	AC
121	60503026	FUSE 3A DELAYED GLASS	ABCD
122	60503065	FUSE 10 A DELAYED GLASS	ABCD
123	60101119	3/8G MALE TO 1/8NPT FEMALE BUSHING	ABCD
124	61405348	CONICAL PLUG TAB D.29.2-32,7	ABCD
125	62617351	CONNECTION STAIN 6P PVC H252MM	ABCD
126	60702085	POLY PROP EXHAUST GASKET 170X170	ABCD

20 - READ OUT FLOW CHART

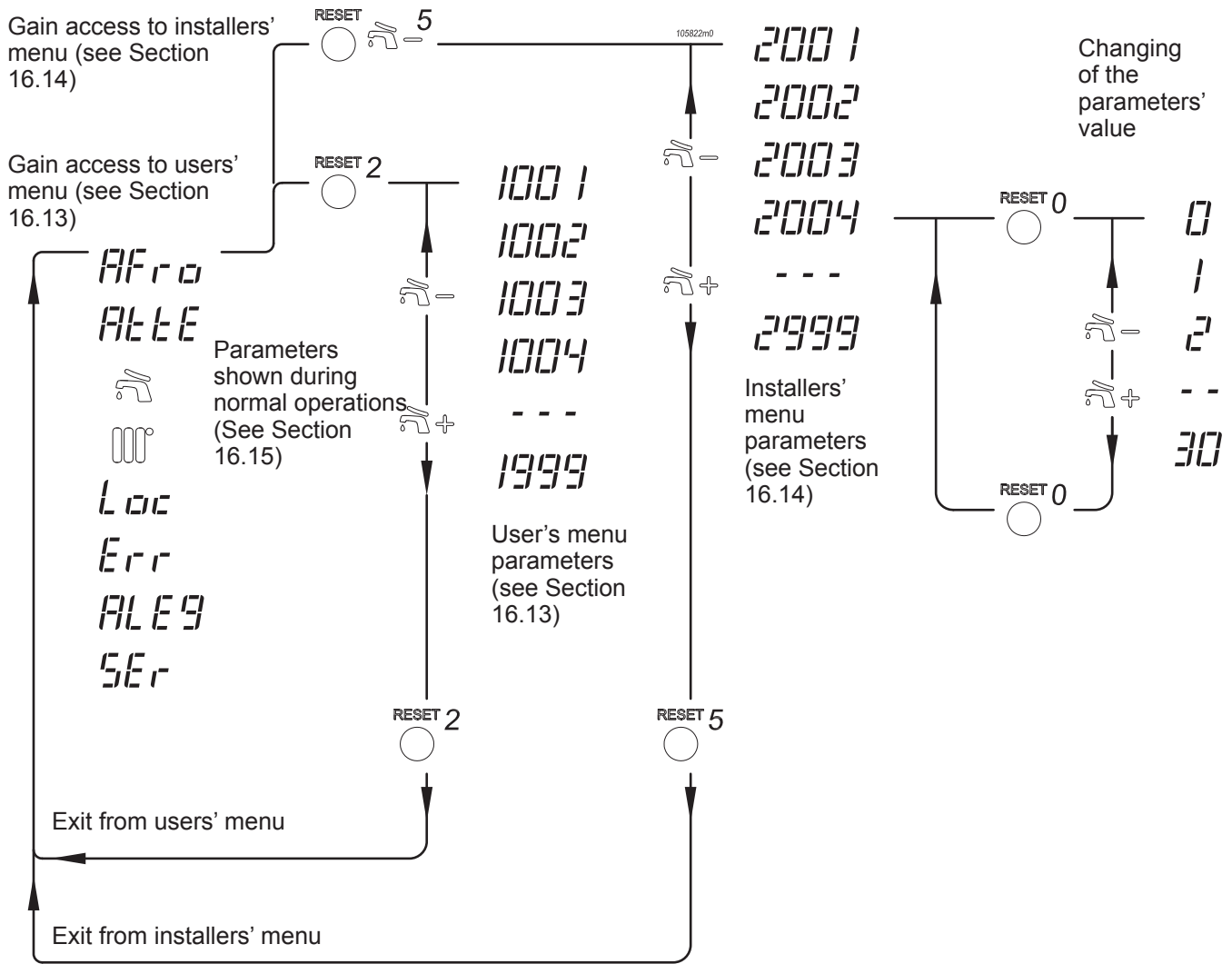

Where:

Symbol	Description
	Push RESET button
	Push and hold the RESET button for at least 2 seconds
	Push and hold the RESET button for at least 5 seconds
	Push and hold together the RESET button and button for the time in seconds displayed
	Push button
	Push button

21 - FACTORY MENU







! WARNING!!! Changing these parameters could cause the heater and the system to malfunction. For this reason, only a qualified technician who has in-depth knowledge of the heater should change them. Failure to comply with this warning can cause extensive property damage, severe personal injury or death!

! WARNING!!! Pay attention when entering the Factory Menu, changes may cause the unit to start. Failure to comply with this warning can cause extensive property damage, severe personal injury or death!

CAUTION!!! On multiburner units (399 up to 1000) display is always connected to the Burner 1 (Master). To change parameters to the other burners you have to move the display connection as per Section 17.7.

The heater's micro-processor makes this menu of parameters available to the qualified technician for the setting of the appliance.

To enter this menu operate as follow:

1. turn the main electrical supply Off;
2. press and hold, in the same time, RESET key and  key;
3. keeping the before mentioned button pressed, turn the power on;
4. wait until the word "init" is displayed or until display start to show the 3000 parameters;
5. leave before the RESET button and after the  key;
6. parameters 3000 start to be displayed;
7. press and release  and  buttons to scroll through the list of the parameters;
8. once the parameter has been selected, it can be changed pressing the RESET button (value start to blinking) and using the  and  keys you can change the value;
9. press RESET key to save the change;
10. wait 10 seconds;
11. turn the main electrical supply Off;
12. turn the main electrical supply On to leave the Factory menu.

21 - FACTORY MENU

Ref.	Parameter's description	Range
3001	Burner logic address	0 = No cascade, 1 = Burner 1 (Master), 2 to 4 = Burner 2 to 4 (slave burners)
3002	Fan speed range	0 to 4
3003	Display units	C = °C and bar units; F = °F and PSI units;
3004	Water pressure sensor	0 = Disabled; 1 = Enabled; 2 = N/A; 3 = N/A
3005	Burner flapper valve	0 = Disabled; 4 = Enabled; 8 = N/A; 12 = N/A;
3006	Water flow sensor	0 = Disabled; 16 = N/A; 32 = N/A; 48 = Enabled
3007	Condensate blocked drain detector	EnAb = Enabled; dISA = Disabled
3008	Flue gas detector	SEnS = Sensor; StCH = Switch
3009	Outdoor thermistor type	10 = 10kohms; 12 = 12kohms;
3010	Other thermistor type	10 = 10kohms; 12 = 12kohms;
3011	Pump MODE	0 = Local pump; 1 = N/A; 2 = N/A; 3 = N/A;
3012	DHW mode	0 = no DHW; 1 = DHW store with sensor; 2 = DHW store with thermostat; 3 = N/A; 4 = N/A; 5 = N/A
3013	Reset Err 115	EnAb = Enabled; dISA = Disabled
3015	Reset curve design: Maximum heating supply temperature (This parameter is overruled by 3017 parameter)	68°F to 194°F
3016	Reset curve design: Minimum heating supply temperature	68°F to 194°F
3017	Maximum supply temperature (This parameter overrule 3015 parameter)	68°F to 194°F
3018	Minimum supply temperature	68°F to 194°F
3020	Type of water flow sensor	0 = N/A; 1 = DN8; 2 = DN 10; 3 = DN 15; 4 = DN 20; 5 = DN 25
3022	Minimum water pressure	0 to 74 PSI
3035	Minimum water flow	0 to 26.4 GPM
3050	Number of slave burners	0 to 3
3085	Modbus address	0 to 126
3086	Number of Stopbits	1 or 2
3100	Material selection	ABS; CPVC; PVC; SST; PP.
3101	Country selection	US = United States; CA = Canada;
Switch "S4"	Position of Switch "S4" (see Figure 17-13)	On or Off

N/A = Not Applicable

21 - FACTORY MENU

Factory settings	IB boilers' parameters		
	Single burner (mod. 199)	Burner 1 (Master) (mod. 399, 500, 750 and 1000)	Burner 2 to 4 (mod. 399, 500, 750 and 1000)
2	0	1	2 to 4
0	199=0	399=0 500=2 750=2 1000=2	399=0 500=2 750=2 1000=2
F	F	F	F
1	1	1	0
4	0	4	4
48	48	48	48
Enab	Enab	Enab	dISA
SEnS	SEnS	SEnS	SEnS
10	10	10	10
10	10	10	10
0	0	0	0
0	1 (if an indirect water heater is present)	1 (if an indirect water heater is present)	0
Enab	Enab	Enab	Enab
179°F	179°F	179°F	179°F
68°F	68°F	68°F	68°F
179°F	179°F	179°F	179°F
89°F	89°F	89°F	89°F
4	4	4	4
14	14	14	14
3.9	11	399 = 11 500 = 12 750 = 12 1000 = 12	399 = 11 500 = 12 750 = 12 1000 = 12
3	3	399 = 1 500 = 1 750 = 2 1000 = 3	3
1	1	1	1
1	1	1	1
PVC	PVC	PVC	PVC
US	US	US	US
On	On	On	Off

IW water heaters' parameters			
Single burner (mod. 199)	Burner 1 (Master) (mod. 399, 500, 750 and 1000)	Burner 2 to 4 (mod. 399, 500, 750 and 1000)	Column for custom. values
0	1	2 to 4	
199=0	399=0 500=2 750=2 1000=2	399=0 500=2 750=2 1000=2	
F	F	F	
1	1	0	
0	4	4	
48	48	48	
Enab	Enab	dISA	
SEnS	SEnS	SEnS	
10	10	10	
10	10	10	
0	0	0	
0	0	0	
Enab	Enab	Enab	
N/A	N/A	N/A	
N/A	N/A	N/A	
179°F	179°F	179°F	
89°F	89°F	89°F	
4	4	4	
14	14	14	
11	399 = 11 500 = 12 750 = 12 1000 = 12	399 = 11 500 = 12 750 = 12 1000 = 12	
3	399 = 1 500 = 1 750 = 2 1000 = 3	3	
1	1	1	
1	1	1	
PVC	PVC	PVC	
US	US	US	
On	On	Off	

22 - SEQUENCE OF OPERATION for BOILER

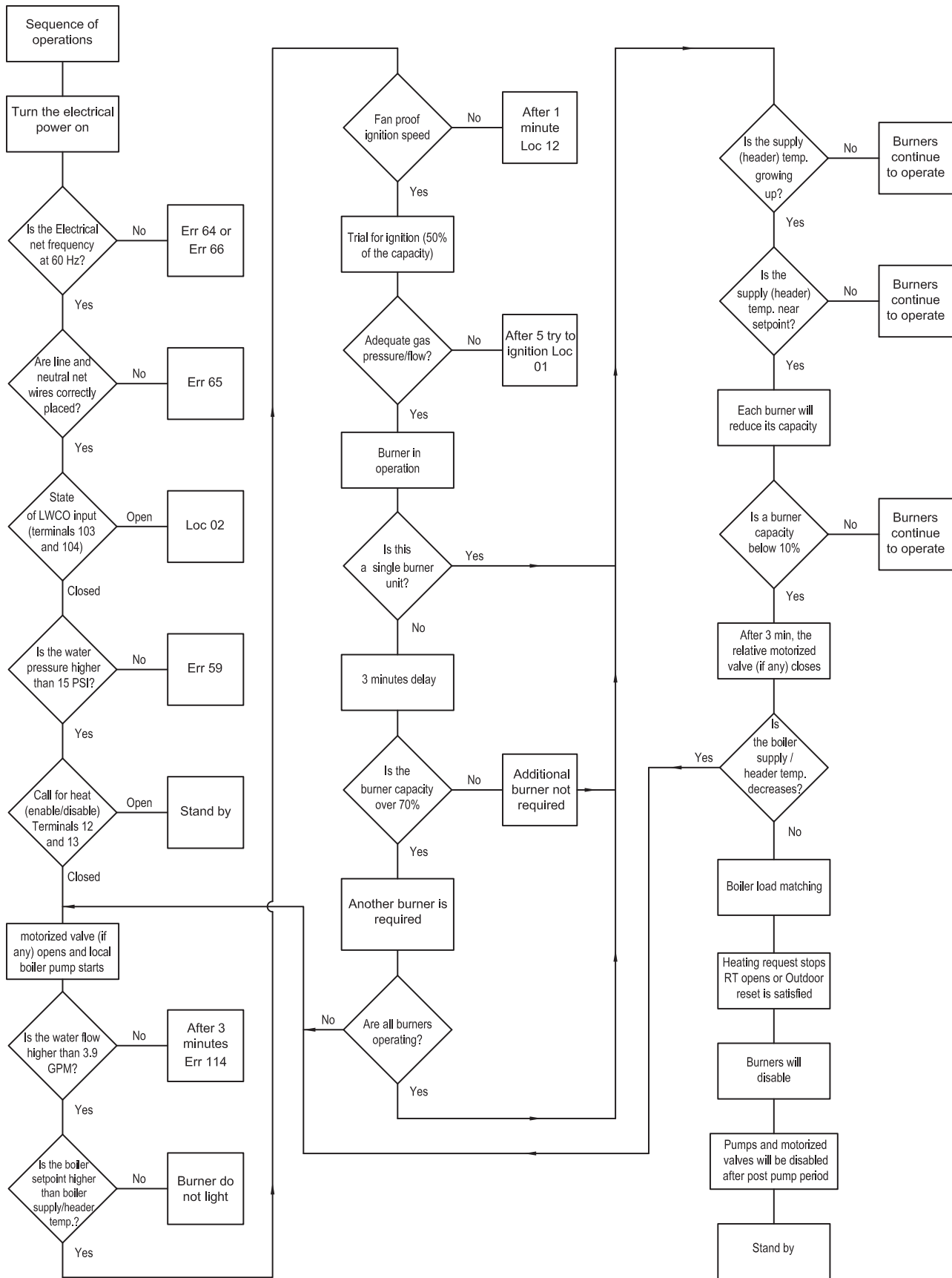

106222m0_s

23 - SEQUENCE OF OPERATION for WATER HEATER

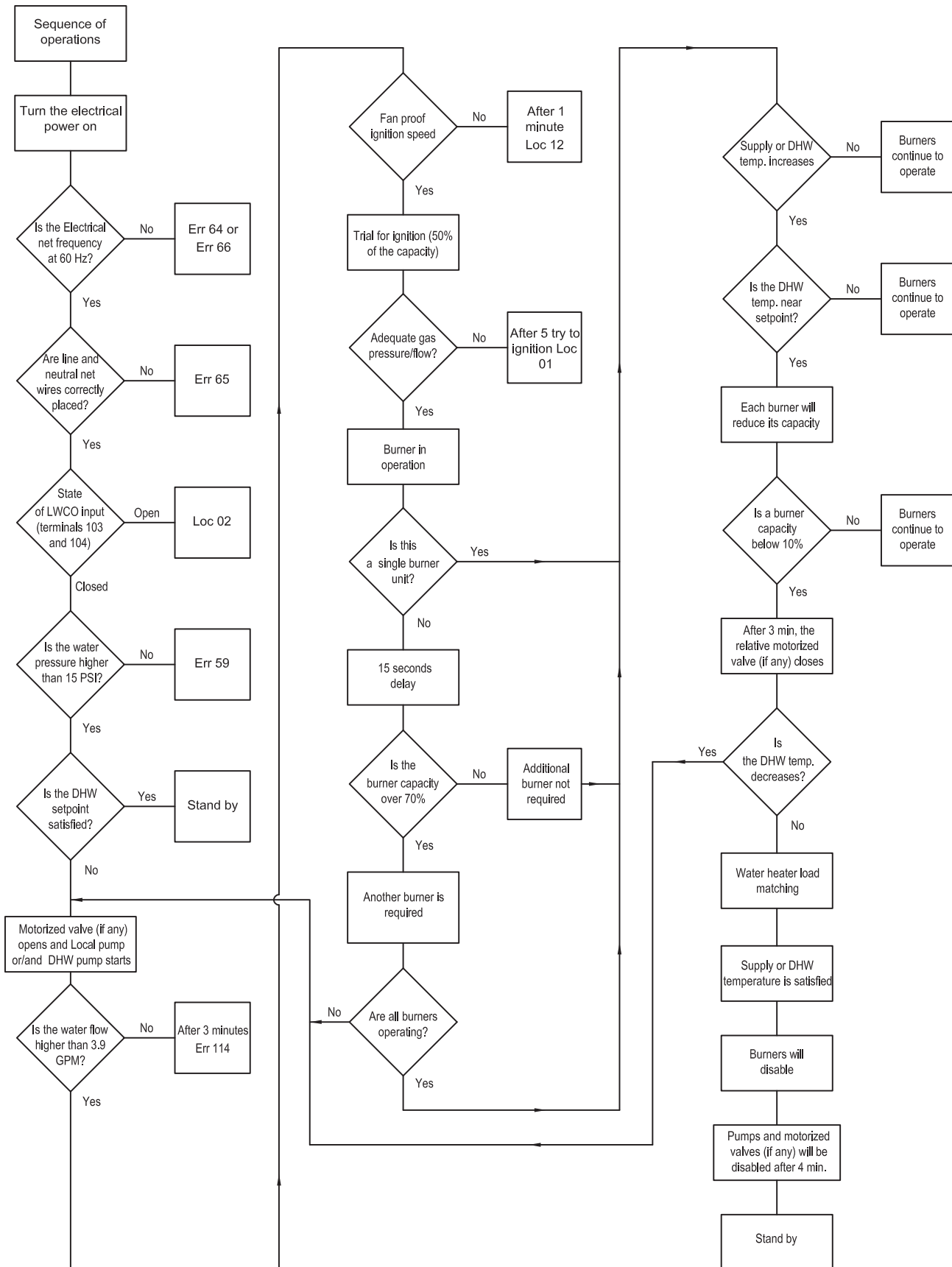

106222mCb

LIMITED WARRANTY

IE2 Boilers/Water Heaters Industrial, Commercial and Other Non-Residential Use

The "Manufacturer" warrants to the original owner at the original installation site that the heat exchanger of the Industrial, Commercial, and other Non-Residential Use Boiler (the "Product") will be free from defects from condensate corrosion and in material or workmanship for ten (10) years from the date of installation. Additional twenty one (21) year thermal shock warranty on heat exchanger. If upon examination by the Manufacturer the Product is shown to have a defect in material or workmanship during the warranty period, the Manufacturer will repair or replace, at its option, that part of the Product which is shown to be defective. All other RBI supplied Boiler/Water Heater parts are warranted against defects in material and workmanship for one (1) year from date of installation or 18 months from date of shipment from RBI.

The "Manufacturer" warrants to the original owner at the original installation site that the heat exchanger of the Industrial, Commercial, and other Non-Residential Use Water Heater (the "Product") will be free from defects from condensate corrosion and in material or workmanship for five (5) years from the date of installation. Additional twenty one (21) year thermal warranty on heat exchanger. If upon examination by the Manufacturer the Product is shown to have a defect in material or workmanship during the warranty period, the Manufacturer will repair or replace, at its option, that part of the Product which is shown to be defective. All other RBI supplied Boiler/Water Heater parts are warranted against defects in material and workmanship for one (1) year from date of installation or 18 months from date of shipment from RBI.

This limited warranty does not apply:

- (a) if the Product has been subjected to misuse or neglect, has been accidentally or intentionally damaged, has not been installed, maintained or operated in accordance with the furnished written instructions, or has been altered or modified in any way.
These include but not limited to:
 - Excessive water hardness causing a lime build-up in the heat exchanger tubes is not a fault of the equipment and is not covered under the manufacturer's warranty.
 - Excessive pitting and erosion on the inside of the heat exchanger tubes caused by high water velocity through the tubes and is not covered by the manufacturer's warranty. (See Installation Instructions for proper pump performance.)
 - Chemical corrosion, no corrosive chemical (freon, dry cleaning chemicals, degreasing liquids, chlorine or any chemicals that produce hydrochloric acid) can be present in the boiler room as it rapidly destroys the heating equipment and voids the warranty.
- (b) to any expenses, including labor or material, incurred during removal or reinstallation of the Product or parts thereof.
- (c) to damage as a result of settlement, distortion, collapse, or cracking of any foundation area, beams or pipes surrounding the Product.
- (d) to any workmanship of any installer of the Product; or to Products installed outside the continental United States or Canada.

This limited warranty is conditional upon:

- (a) shipment, to the Manufacturer, of that part of the Product thought to be defective. Goods can only be returned with prior written approval from the Manufacturer. All returns must be freight prepaid.
- (b) determination in the reasonable opinion of the Manufacturer that there exists a defect in material or workmanship.

Repair or replacement of any part under this Limited Warranty shall not extend the duration of the warranty with respect to such repaired or replaced part beyond the stated warranty period.

THIS LIMITED WARRANTY IS IN LIEU OF ALL OTHER WARRANTIES, EITHER EXPRESS OR IMPLIED, AND ALL SUCH OTHER WARRANTIES, INCLUDING WITHOUT LIMITATION IMPLIED WARRANTIES OF MERCHANTABILITY OR FITNESS FOR A PARTICULAR PURPOSE, ARE HEREBY DISCLAIMED AND EXCLUDED FROM THIS LIMITED WARRANTY. IN NO EVENT SHALL THE MANUFACTURER BE LIABLE IN ANY WAY FOR ANY CONSEQUENTIAL, SPECIAL, OR INCIDENTAL DAMAGES OF ANY NATURE WHATSOEVER, OR FOR ANY AMOUNTS IN EXCESS OF THE SELLING PRICE OF THE PRODUCT OR ANY PARTS THEREOF FOUND TO BE DEFECTIVE. THIS LIMITED WARRANTY GIVES THE ORIGINAL OWNER OF THE PRODUCT SPECIFIC LEGAL RIGHTS. YOU MAY ALSO HAVE OTHER RIGHTS WHICH MAY VARY BY EACH JURISDICTION.



260 North Elm Street
Westfield, MA 01085
Phone: (413) 568-9571
Fax: (413) 568-9613

7555 Tranmere Drive
Mississauga, Ontario L5S 1L4 Canada
Phone: (905) 670-5888
Fax: (905) 670-5782

www.rbiwaterheaters.com



A MESTEK COMPANY