

Smith

CAST IRON BOILERS



GVSC

Gas-Fired Residential Boilers

Boiler Manual

Installation and Operation Instructions



Intertek

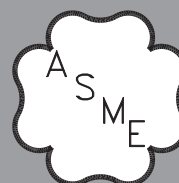

H



WARNING This manual is intended only for use by a qualified heating installer/technician. Read and follow this manual, all supplements and related instructional information provided with the boiler. Install, start and service the boiler only in the sequence and methods given in these instructions. Failure to do so can result in severe personal injury, death or substantial property damage.

WARNING **Do not use the boiler during construction.** Construction dust and particulate, particularly drywall dust, will cause contamination of the burner, resulting in possible severe personal injury, death or substantial property damage. The boiler can only be operated with a dust-free air supply. Follow the instruction manual procedures to duct air to the boiler air intake. If the boiler has been contaminated by operation with contaminated air, follow the instruction manual guidelines to clean, repair or replace the boiler if necessary.

CAUTION Affix these instructions near to the boiler/water heater. Instruct the building owner to retain the instructions for future use by a qualified service technician, and to follow all guidelines in the User's Information Manual.

TABLE OF CONTENTS

USING THIS MANUAL	3	5. GAS PIPING	15
A. INSTALLATION SEQUENCE	3	6. ELECTRICAL	17
B. SPECIAL ATTENTION BOXES	3	A. WIRING	17
1. PREINSTALLATION	4	B. ZONED SYSTEM WIRING	17
A. ACCESSIBILITY CLEARANCES	4	C. CONTROLS	17
B. CLEARANCE FROM COMBUSTIBLE CONSTRUCTION	4	D. BOILER SEQUENCE OF OPERATION	19
C. PLANNING THE LAYOUT	5	7. START-UP PROCEDURES	19
D. MASSACHUSETTS INSTALLATIONS	5	A. COMPLETING THE INSTALLATION	19
2. BOILER SET-UP	5	B. CONTROL DESCRIPTIONS	23
3. WATER PIPING AND CONTROLS	6	C. ADJUSTMENT OF GAS PRESSURE REGULATOR	23
A. BOILER SUPPLY AND RETURN	6	D. CHECKING BURNER INPUT	23
B. SAFETY RELIEF VALVE	7	E. CHECK-OUT PROCEDURE	23
C. PIPING FOR ZONED SYSTEMS	8	8. TROUBLESHOOTING	25
D. EXPANSION TANK	9	A. SHUT-DOWN CAUSED BY PILOT OUTAGE, PRESSURE SWITCH OR FLAME ROLL-OUT SAFETY SHUT-OFF SWITCH	25
E. INDIRECT-FIRED WATER HEATER	9	B. TROUBLESHOOTING GUIDES	25
F. FREEZE PROTECTION	9	C. MEASURING SUCTION PRESSURE	25
4. VENTING, VENTILATION AND AIR INLET	10	9. MAINTENANCE	28
A. GENERAL	10	A. GENERAL	29
B. WALL THIMBLE	10	B. DAILY (WITH BOILER IN USE)	29
C. ROOF TERMINATIONS	12	C. WEEKLY (WITH BOILER IN USE)	29
D. CONDENSATE TRAP INSTALLATION	12	D. MONTHLY (WITH BOILER IN USE)	29
E. VENT PIPE INSTALLATION	12	E. ANNUALLY (BEFORE START OF HEATING SEASON)	29
F. AIR INLET PIPE INSTALLATION	14	10. BOILER DIMENSIONS & RATINGS	31
G. AIR FOR VENTILATION	14	11. REPAIR PARTS	32
H. BOILER REMOVAL FROM COMMON VENTING SYSTEM	14		

USING THIS MANUAL

A. INSTALLATION SEQUENCE

Follow the installation instructions provided in this manual in the order shown. The order of these instructions has been set in order to provide the installer with a logical sequence of steps that will minimize potential interferences and maximize safety during boiler installation.

B. SPECIAL ATTENTION BOXES

Throughout this manual you will see special attention boxes intended to supplement the instructions and make special notice of potential hazards. These categories mean, in the judgment of Smith:

DANGER

Indicates a condition or hazard which will cause severe personal injury, death or major property damage.

WARNING

Indicates a condition or hazard which may cause severe personal injury, death or major property damage.

CAUTION

Indicates a condition or hazard which will or can cause minor personal injury or property damage.

NOTICE

Indicates special attention is needed, but not directly related to potential personal injury or property damage.

1. PREINSTALLATION

Read carefully, study these instructions before beginning work.

This boiler must be installed by a qualified contractor.

The boiler warranty can be voided if the boiler is not installed, maintained and serviced correctly.

NOTICE

The equipment must be installed in accordance with those installation requirements of the authority having jurisdiction or, in the absence of such requirements, to the current edition of the *National Fuel Gas Code*, ANSI Z223.1/NFPA 54 and/or CAN/CSA B49.1, *Natural Gas and Propane Installation Code*.

Where required by the authority having jurisdiction, the installation must conform to *American Society of Mechanical Engineers Safety Code for Controls and Safety Devices for Automatically Fired Boilers*, ANSI/ASME CSD-1.

IMPORTANT

In accordance with Section 325 (f) (3) of the Energy Policy and Conservation Act, this boiler is equipped with a feature that saves energy by reducing the boiler water temperature as the heating load decreases. This feature is equipped with an override which is provided primarily to permit the use of an external energy management system that serves the same function.

THIS OVERRIDE MUST NOT BE USED UNLESS AT LEAST ONE OF THE FOLLOWING CONDITIONS IS TRUE:

- An external energy management system is installed that reduces the boiler water temperature as the heating load decreases.
- This boiler is not used for any space heating
- This boiler is part of a modular or multiple boiler system having a total input of 300,000 BTU/hr or greater.
- This boiler is equipped with a tankless coil.

A. ACCESSIBILITY CLEARANCES

Install boiler not less than 24" (610 mm) between the left side, top, and front of the boiler and adjacent wall or other appliance, when access is required for servicing.

B. CLEARANCE FROM COMBUSTIBLE CONSTRUCTION

The design of this boiler is certified for closet installation with the following clearances:

1. 6" (152 mm) between right side, front and combustible construction.
2. 12" (305 mm) between top of jacket and combustible construction.
3. 1" (25 mm) between left side, rear and combustible construction.
4. 2" (51 mm) between vent pipe and combustible construction.
5. Zero clearance between wall thimble and combustible construction.
6. This boiler is design certified for use on combustible flooring.

DANGER

Do not install this boiler on carpeting. Boiler installation on carpeting is a fire hazard. Install this boiler on non-combustible flooring or use a combustible floor pan to install this boiler on other non-carpeted flooring.

WARNING

Liquefied Petroleum (LP) is heavier than air and may collect or "pool" in a low area in the event of a leak from defective equipment. This gas may then ignite, resulting in a fire or explosion.

C. PLANNING THE LAYOUT

Prepare sketches and notes of the layout to minimize the possibility of interferences with new or existing equipment, piping, venting and wiring. Review limitations on vent pipe, vent terminal, and air inlet pipe locations and ventilation air requirements in Section 4.

D. MASSACHUSETTS INSTALLATIONS

Massachusetts requires manufacturers of Side Wall Vented boilers to provide the following information from the Massachusetts code:

- A hard wired carbon monoxide detector with an alarm and battery back-up must be installed on the floor level where the gas equipment is to be installed AND on each additional level of the dwelling, building or structure served by the side wall horizontal vented gas fueled equipment.
 - In the event that the side wall horizontally vented gas fueled equipment is installed in a crawl space or an attic, the hard wired carbon monoxide detector with alarm and battery back-up may be installed on the next adjacent floor level.
 - Detector(s) must be installed by qualified licensed professionals.
 - APPROVED CARBON MONOXIDE DETECTORS: Each carbon monoxide detector shall comply with NFPA 720 and be ANSI/UL 2034 listed and IAS certified.
 - SIGNAGE: A metal or plastic identification plate shall be permanently mounted to the exterior of the building at a minimum height of eight (8) feet above grade directly in line with the exhaust vent terminal for the horizontally vented gas fueled heating appliance or equipment. The sign shall read, in print size no less than one-half (1/2) inch in size, **"GAS VENT DIRECTLY BELOW. KEEP CLEAR OF ALL OBSTRUCTIONS"**.
- EXEMPTIONS to the requirements listed above:
 - The above requirements do not apply if the exhaust vent termination is seven (7) feet or more above finished grade in the area of the venting, including but not limited to decks and porches.
 - The above requirements do not apply to a boiler installed in a room or structure separate from the dwelling, building or structure used in whole or in part for residential purposes.
 - This boiler installation manual shall remain with the boiler at the completion of the installation.

See the latest edition of Massachusetts Code 248 CMR for complete verbiage and also for additional (non-vent related) requirements (248 CMR is available online).

If your installation is NOT in Massachusetts, please see your authority of jurisdiction for requirements that may be in effect in your area. In the absence of such requirements, follow the *National Fuel Gas Code*, ANSI Z223.1/NFPA 54 and/or CAN/CSA B149.1, *Natural Gas and Propane Installation Code*.

Venting System Installation Instructions – See boiler manual and instructions provided with the Venting System components. Additional copies may be obtained from the Venting System Manufacturer by visiting the following web addresses:

Heat-Fab – www.selkirkcorp.com/heatfab

Z-Flex – www.NovaFlex.com

Pro-Tech – www.protechinfo.com

2. BOILER SET-UP

1. Provide a sound, level foundation. Locate boiler as near to the outside wall as possible and centralized with respect to the heating system.
2. Locate boiler in front of installation position before removing crate.
3. Remove the boiler from the shipping pallet by separating the pallet from the boiler base.
4. Separate the wood shipping pallet from the boiler base by removing two (2) hold-down bolts at each end of the boiler base.
5. Move boiler into final position.

3. WATER PIPING AND CONTROLS

A. BOILER SUPPLY AND RETURN

1. Size the supply and return to suit the system. A typical piping arrangement is shown in Figure 3.1. Refer also to the Hydronics Institute Residential Hydronic Heating Installation Design Guide for additional guidance during water piping installation.
2. Return Piping:
Pipe the outlet connection of the circulator to a tee, provided with a drain valve, at the 1-1/4" NPT return tapping near the bottom of the right section. Pipe the return to the inlet connection of the circulator.
3. Supply Piping:
 - a. Pipe the supply to the 1-1/2" NPT supply tapping at the top of the boiler.
 - b. Provide clearance to venting system (see Section 4).
4. When system return water temperature will be below 130°F (54°C), pipe the boiler with a bypass arrangement to blend the system return and hot supply to obtain at least 130°F (54°C) entering the boiler.
5. If desired, install the circulator in the alternate location shown in Figure 3.1.

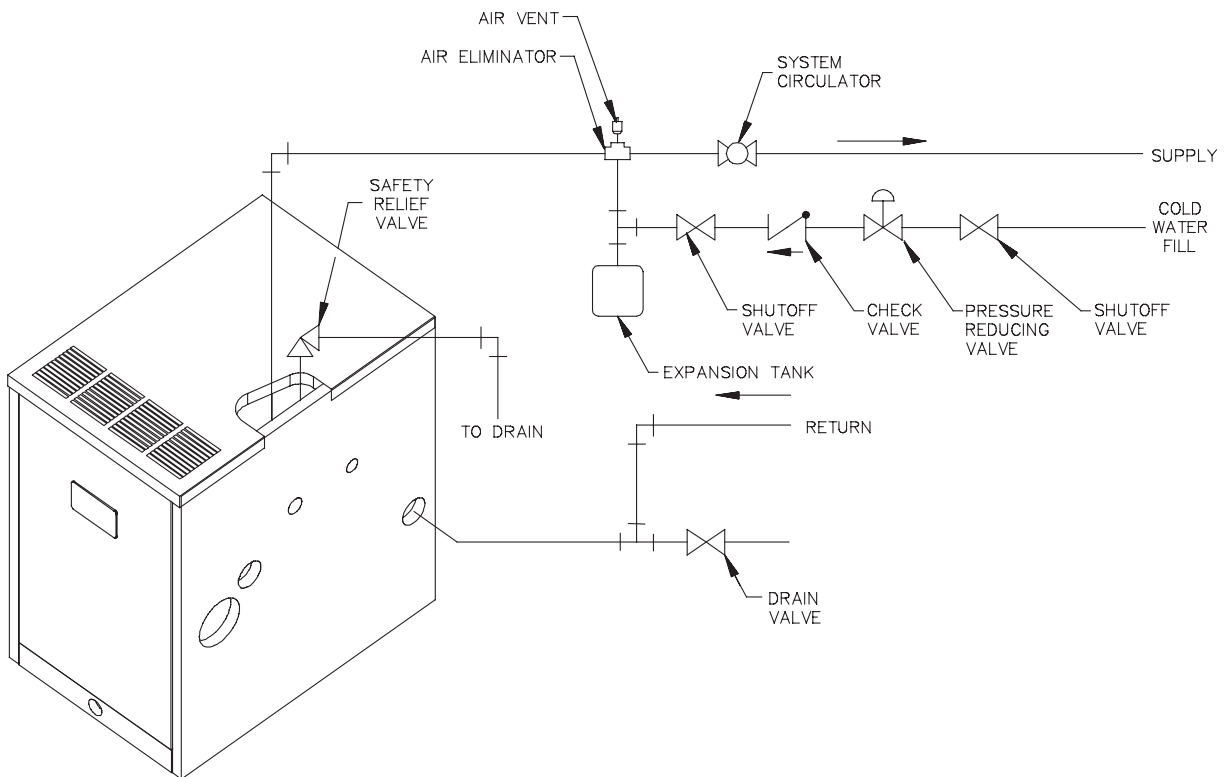

Figure 3.1: Supply and Return Piping

6. Install this boiler so that the gas ignition system components are protected from water (dripping, spraying, etc.) during appliance operation and service (circulator replacement, condensate trap, control replacements, etc.).
7. If this boiler and distribution system is used in conjunction with a refrigeration system, pipe the chilled medium in parallel with the boiler and install the proper valve to prevent the chilled medium from entering the boiler. A drawing illustrating this hook-up is provided in Figure 3.2.
8. When the boiler is connected to heating coils located in air handling units where they may be exposed to refrigerated air circulation, install flow control valves or other automatic means to prevent gravity circulation of the boiler water during the cooling cycle.
9. If this boiler is installed above radiation level, provide a low water cutoff device, either as a part of the boiler or at the time of boiler installation.

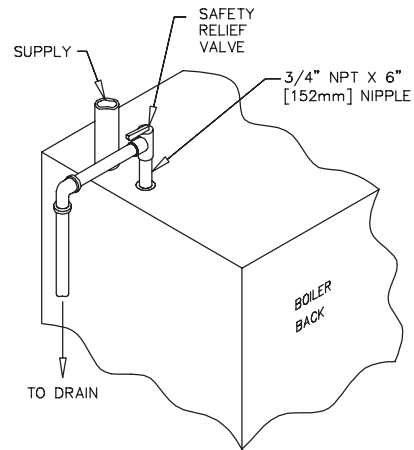

Figure 3.3: Safety Relief Valve Hook-Up Installation with Air Elimination in System Piping

B. SAFETY RELIEF VALVE

1. Locate safety relief valve and fittings in bag assembly.
2. If air elimination is not required at the safety relief valve tapping, install valve and piping as shown in Figure 3.3.
3. For air elimination at the safety relief valve tapping, install valve and piping as shown in Figure 3.4.

CAUTION

Pipe the discharge of safety relief valve to prevent injury in the event of pressure relief. Pipe the discharge to a drain. Provide piping that is the same size as the safety relief valve outlet.

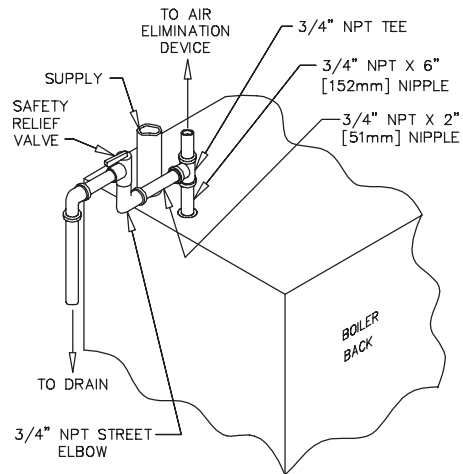

Figure 3.4: Safety Relief Valve Hook-Up with Air Elimination

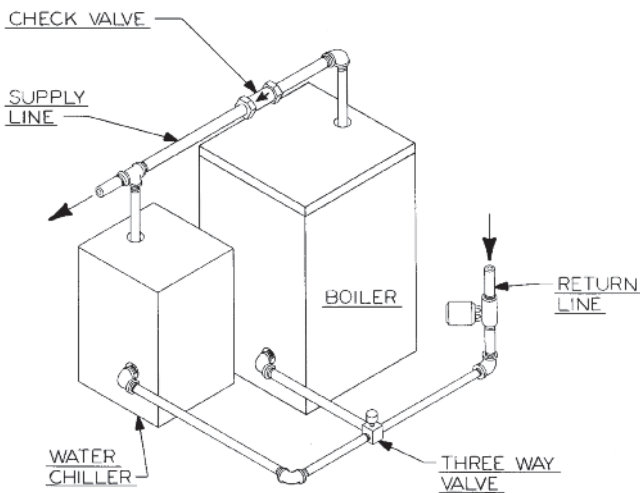

Figure 3.2: Parallel Hook-up with Water Chiller

C. PIPING FOR ZONED SYSTEMS

1. See Figures 3.5 and 3.6 for basic zoned system layouts.
2. Run each zone pipe down then up to zone to prevent air accumulation in piping.
3. If required, provide means to isolate and drain each zone separately.

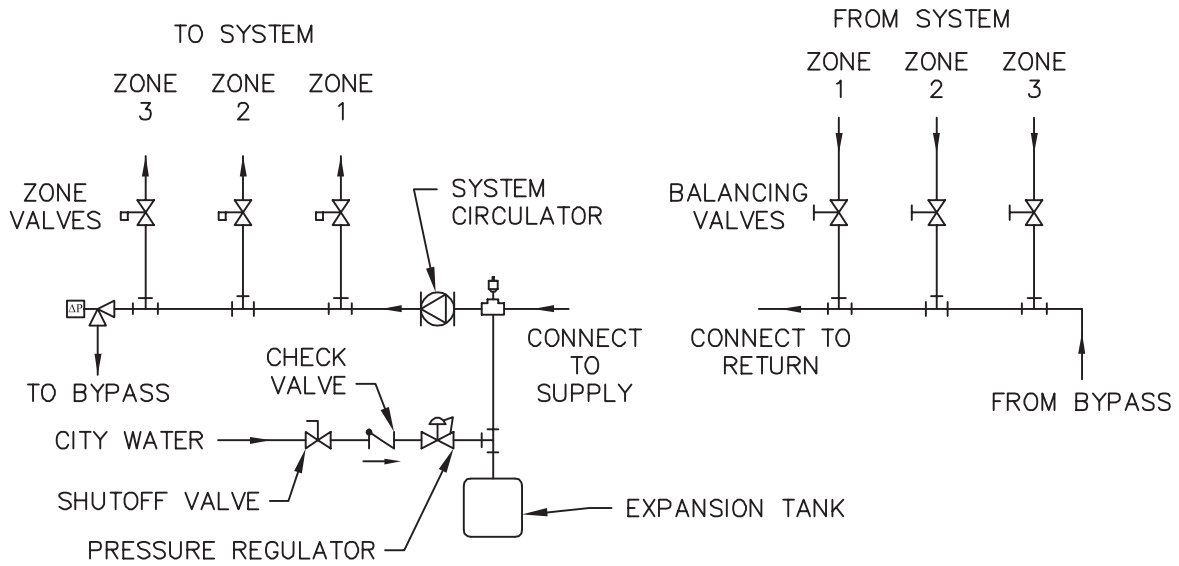

Figure 3.5: Zone Piping with Zone Valves

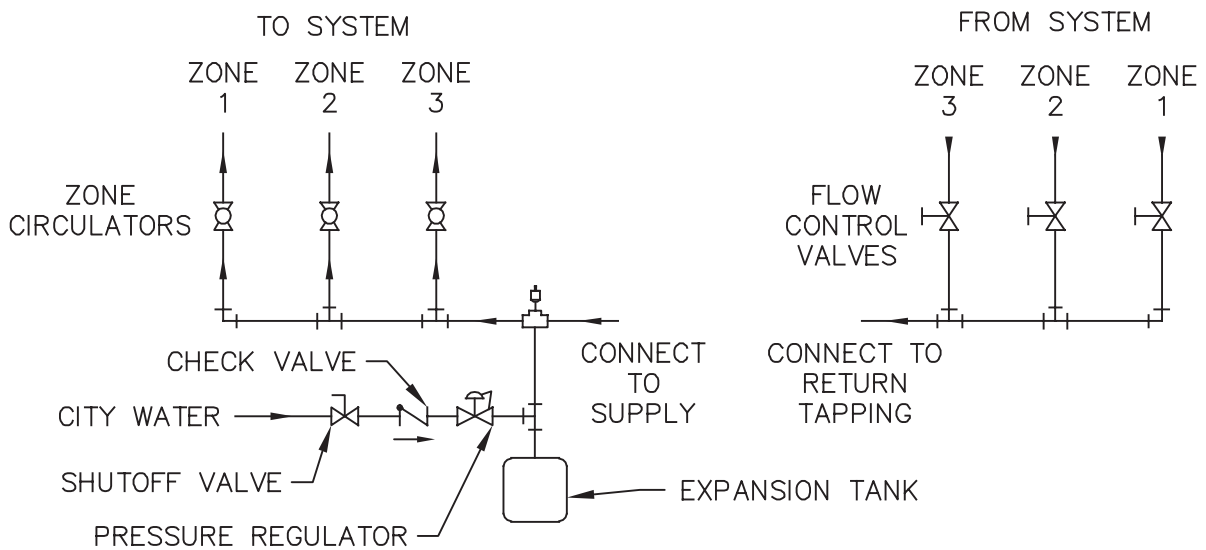

Figure 3.6: Zone Piping with Circulators

D. EXPANSION TANK

1. Consult the tank manufacturer's instructions for specific information relating to tank installation. Size the expansion tank for the required system volume and capacity. See Table 10.2 in Section 10 for boiler water capacity.
2. Expansion tanks are available with built-in fill valves and check valves for reducing supply water pressure and maintaining minimum system pressure. Check the design features of the tank and provide valves as necessary.

Refer back to Figure 3.1 for typical expansion tank piping.

E. INDIRECT-FIRED WATER HEATER

If the boiler is to be used in conjunction with an indirect-fired water heater, refer to Figure 3.7 for typical piping. Follow the instructions provided by the water heater manufacturer. Pipe the water heater as a separate zone.

F. FREEZE PROTECTION

For new or existing systems that must be freeze-protected:

WARNING

Use only inhibited propylene glycol solutions of up to 50% by volume with water. Ethylene glycol is toxic and can attack gaskets and seals used in hydronic systems.

1. Glycol in hydronic applications is specially formulated for this purpose. It includes inhibitors which prevent the glycol from attacking metallic system components. Make certain that the system fluid is checked for the correct glycol concentration and inhibitor level.
2. The glycol solution should be tested at least once a year and as recommended by the antifreeze manufacturer.
3. Glycol solutions expand more than water. For example, a 50% by volume solution expands 4.8% in volume for a temperature increase from 32°F (0°C) to 180°F (82°C), while water expands 3% with the same temperature rise. Allowance must be made for this expansion in system design.

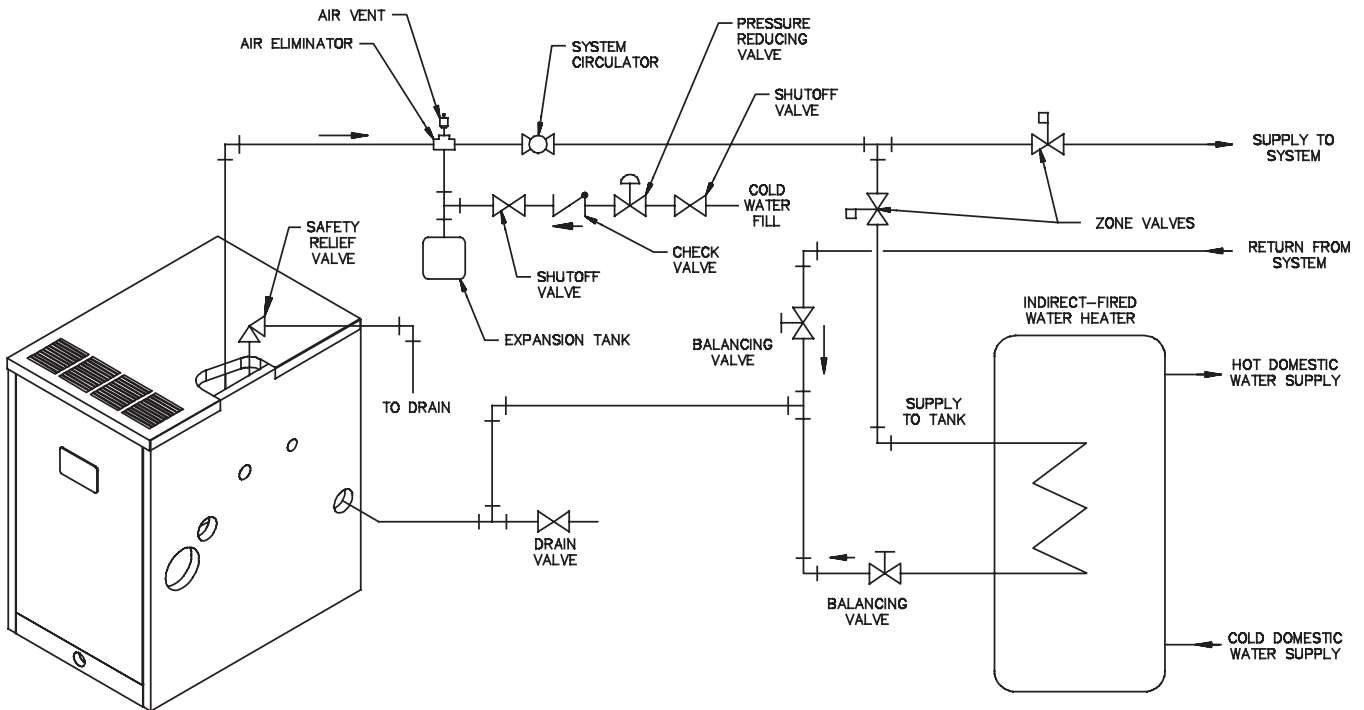

Figure 3.7: Typical Piping with Indirect-Fired Water Heater

4. VENTING, VENTILATION AND AIR INLET

A. GENERAL

Install vent system in accordance with Venting of Equipment part of the *National Fuel Gas Code*, ANSI z223.1/NFPA 54 or sections 7.2, 7.3 or 7.4 of CAN/CSA B149.1, *Natural Gas and Propane Installation Code*.

WARNING

This vent system will operate with a positive pressure in the vent pipe. Do not connect vent connectors serving appliances vented by natural draft into any portion of mechanical draft systems operating under positive pressure.

WARNING

All joints of positive pressure vent systems must be sealed completely to prevent leakage of flue products into the living space.

NOTICE

Flue gases will condense as they exit the vent termination. This condensate can freeze on exterior building surfaces which may cause discoloration of these surfaces.

B. WALL THIMBLE (SIDEWALL VENTING ONLY)

1. Determine vent cap (terminal) location.
 - a. Must be within the maximum and minimum vent and air intake lengths shown in Tables 4.1 and 4.2.
 - b. Maximum wall thickness for the 19-1/2" (495 mm) long Wall Thimble (standard) is 11-1/2" (292 mm). Maximum wall thickness for the optional 28" (711 mm) long thimble is 20" (508 mm).

- c. Provide 2" (51 mm) clearance between vent pipe and combustible construction. No clearance is required between Thimble and combustible construction.
- d. Provide 3 feet (1 meter) clearance above any forced air inlet within 10 feet (3 meters).
- e. Provide 1 foot (0.3 meters) clearance below and 1 foot (0.3 meters) beside, or 1 foot (0.3 meters) above any door, window, or gravity air inlet into any building.
- f. Provide 1 foot (0.3 meters) clearance between bottom of vent terminal and ground level and normal snow lines.
- g. Provide 4 feet (1.2 meters) horizontal clearance from electric meters, gas meters, regulators and relief equipment. In Canada, this dimension must be 6 feet (2 meters).
- h. Do not locate vent terminal over public walkways where condensate could create a nuisance or hazard.
- i. When adjacent to a public walkway, locate vent terminal at least 7 feet (2.1 meters) above grade.
- j. Do not locate directly under roof overhangs to prevent icicles from forming.

2. Cut a 5-1/8" (130 mm) square hole in sidewall to allow wall thimble to go through.
3. Insert Thimble from inside wall with 4" (102 mm) diameter air inlet connection facing down. Extend Thimble 3-1/2" (89 mm) past outside wall surface. The cut-out opening of thimble is pointed down.
4. Use a minimum 2-1/2 foot (762 mm) piece of 3" (76 mm) diameter AL29-4C stainless steel vent pipe for insertion through Wall Thimble. See Vent Pipe section below for vent pipe requirements.

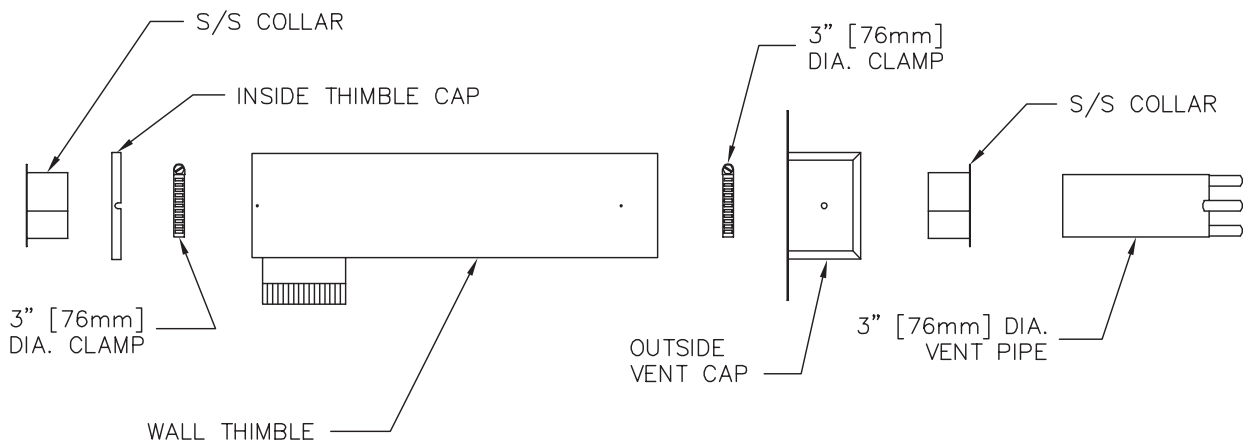

Figure 4.1: Wall Thimble

5. Slide Stainless Steel Collar over vent pipe and slide to end of pipe.
6. Insert pipe with collar through Outside Vent Cap and slide 3" (76 mm) diameter hose clamp over collar.
7. Leave at least 2" (51 mm) of vent pipe protruding beyond face of Vent Cap and secure hose clamp and collar to vent pipe.
8. Place Outside Vent Cap over Wall Thimble with air openings in Vent Cap facing down. Secure Cap to Thimble with #10 sheet metal screws.
9. Place 3" (76 mm) diameter hose clamp over pipe protruding through inside of Wall Thimble.
10. Place Inside Thimble Cap and Collar onto Wall Thimble. Access hose clamp through 4" (102 mm) diameter collar on bottom of Thimble and secure hose clamp over collar and vent pipe as per step 7 above.
11. Secure Inside Thimble cap to Wall Thimble with #10 screws. Seal Thimble Cap perimeter with silicone.
12. Seal all openings between Wall and Thimble and around the 3" (76 mm) diameter stainless steel vent pipe that protrudes through inside and outside of Wall Thimble.
13. Add any bracing that may be needed to support Wall Thimble on inside of wall structure.
14. Secure Outside Vent Cap to exterior wall with four #10 sheet metal screws provided.
15. Attach Z-Flex #2SVSTPF03 terminal to protruding vent pipe. Refer to Figure 4.2. To attach to HEAT-FAB pipe, insert into pipe end and fold over tabs to secure. Otherwise, silicone terminal to vent pipe.

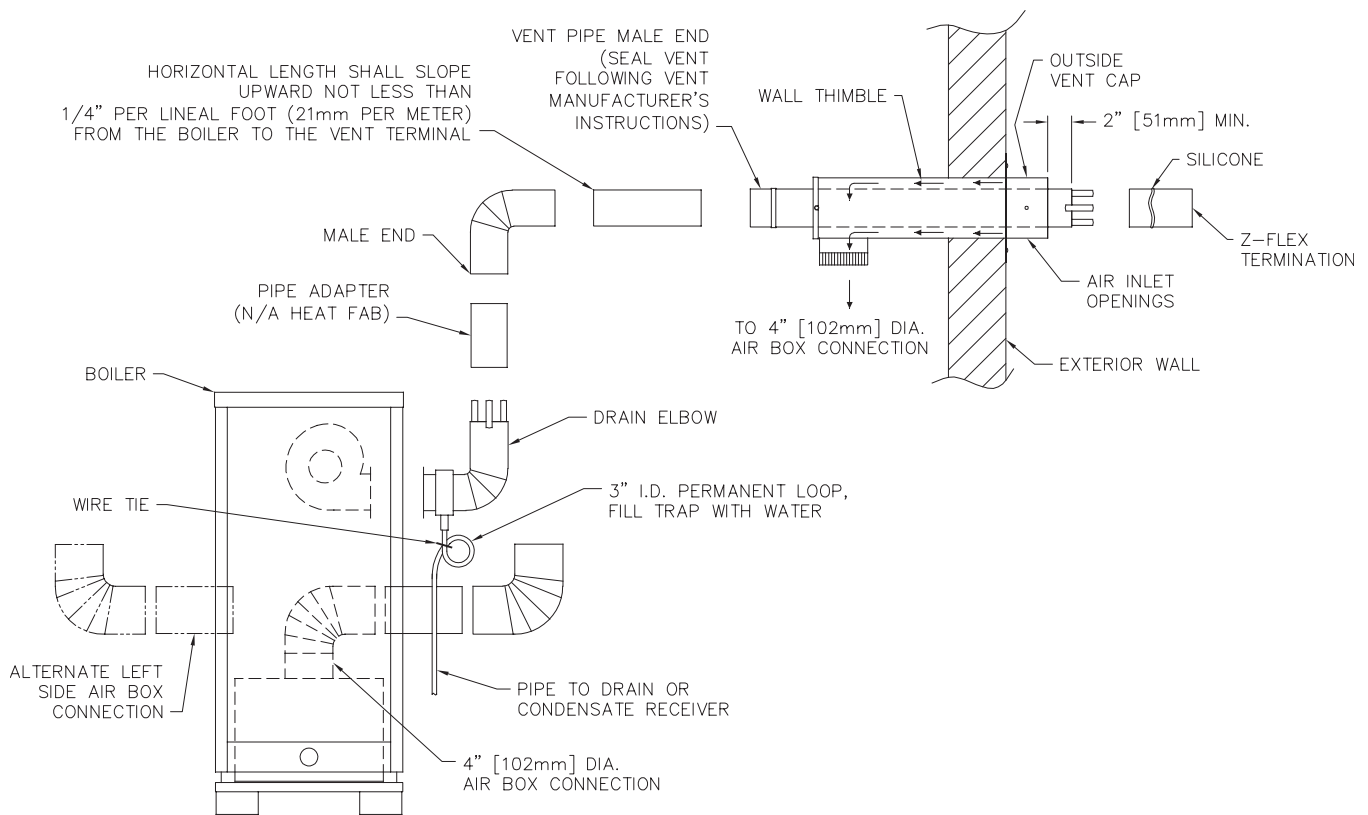

Figure 4.2: Side Wall Venting System

C. ROOF TERMINATIONS (VERTICAL VENTING)

- Vent pipe and air inlet terminations must be within the maximum and minimum vent and air intake lengths shown in Tables 4.1 and 4.2.

Table 4.1

Boiler Model	*Equivalent Length of 3" (76 mm) Diameter Stainless Steel Vent Pipe	
	Minimum Vent Length	Maximum Vent Length
GVSC-03	8 feet (2.5 m)	52 feet (15.5 m)
GVSC-04	8 feet (2.5 m)	52 feet (15.5 m)
GVSC-05	8 feet (2.5 m)	45 feet (13.5 m)
GVSC-06	8 feet (2.5 m)	45 feet (13.5 m)

Table 4.2

Boiler Model	*Equivalent Length of 4" (102 mm) Diameter Aluminum/Galvanized Air Inlet Pipe	
	Minimum Length	Maximum Length
GVSC-03	12 feet (4.0 m)	70 feet (21.0 m)
GVSC-04	12 feet (4.0 m)	70 feet (21.0 m)
GVSC-05	12 feet (4.0 m)	63 feet (19.0 m)
GVSC-06	12 feet (4.0 m)	63 feet (19.0 m)

* Each 90° elbow equals 5 feet (1.5 meters) of equivalent length.

- Vent pipe and air inlet pipe must terminate 12" (305 mm) above expected snow lines. Vent pipe must be a minimum 12" (305 mm) above and 12" (305 mm) horizontally from air inlet pipe. See Figure 4.3.
- Attach a vent manufacturer's listed rain cap to both the vent pipe and air inlet pipe.
- Provide 2" (51 mm) clearance between vent pipe and combustible construction. No clearance is required between air inlet pipe and combustible construction.
- See vertical venting section in vent manufacturer's instructions for recommendations for penetration through roof.

D. CONDENSATE TRAP INSTALLATION

Locate condensate hose and cable tie in Accessory Carton. Connect hose to drain fitting on condensate elbow. Form a 3" diameter loop and secure with cable tie. Fill loop with water. Pipe to drain or condensate receiver. See Figure 4.2.

E. VENT PIPE INSTALLATION

- For minimum and maximum vent pipe lengths see Table 4.1.
- Use only 3" (76 mm) diameter Type AL29-4C stainless steel vent pipe and fittings for venting of flue gases from the boiler. When using other than Heat-Fab vent pipe, an adapter must be installed on the outlet of condensate elbow. See Figure 4.2. Adapter part numbers are as follows:

Pipe Manufacturer	Adapter
Flex-L Star-34	SRAPSCA3*
Heat-Fab Saf-T Vent	Adapter not required
ProTech FasNSeal	FSA-HFA3*
Z-Flex Z-Vent	2SVSSLA2*

* Available from Vent Pipe Manufacturer

- Attach remaining pipe and fittings per each manufacturer's vent instructions. Use only the silicone recommended by vent pipe manufacturers. Maintain proper clearance to combustible construction – see Section 1, Preinstallation.
- Horizontal portions of the vent pipe shall slope upward from the boiler towards the vent termination, not less than 1/4" per foot (21 mm per meter).
Parties horizontales de l'évent doit pente ascendante de la chaudière vers la terminaison de ventilation, pas moins de 1/4 "par pied (21 mm par mètre).
- Support horizontal lengths of the vent system to prevent sagging by use of metal strapping or equivalent means. Locate supports at not more than four (4) foot intervals.
Fournir un support à toute portion horizontale du système d'évacuation à l'aide de courroies de metal ou une méthode équivalente afin de l'empêcher de s'affaisser. Placer les supports à des intervalles ne dépassant pas cent vingt deux (122) centimètres (4 po), ou en suivant les recommandations d'installation du fabricant.
- Vertical Venting Only** – If there is no solid anchor point in the system below the roof for supporting vertical sections of the vent pipe (i.e. Firestop Support, etc.), a special vent support system will be required. See vent manufacturer's instructions for additional information.

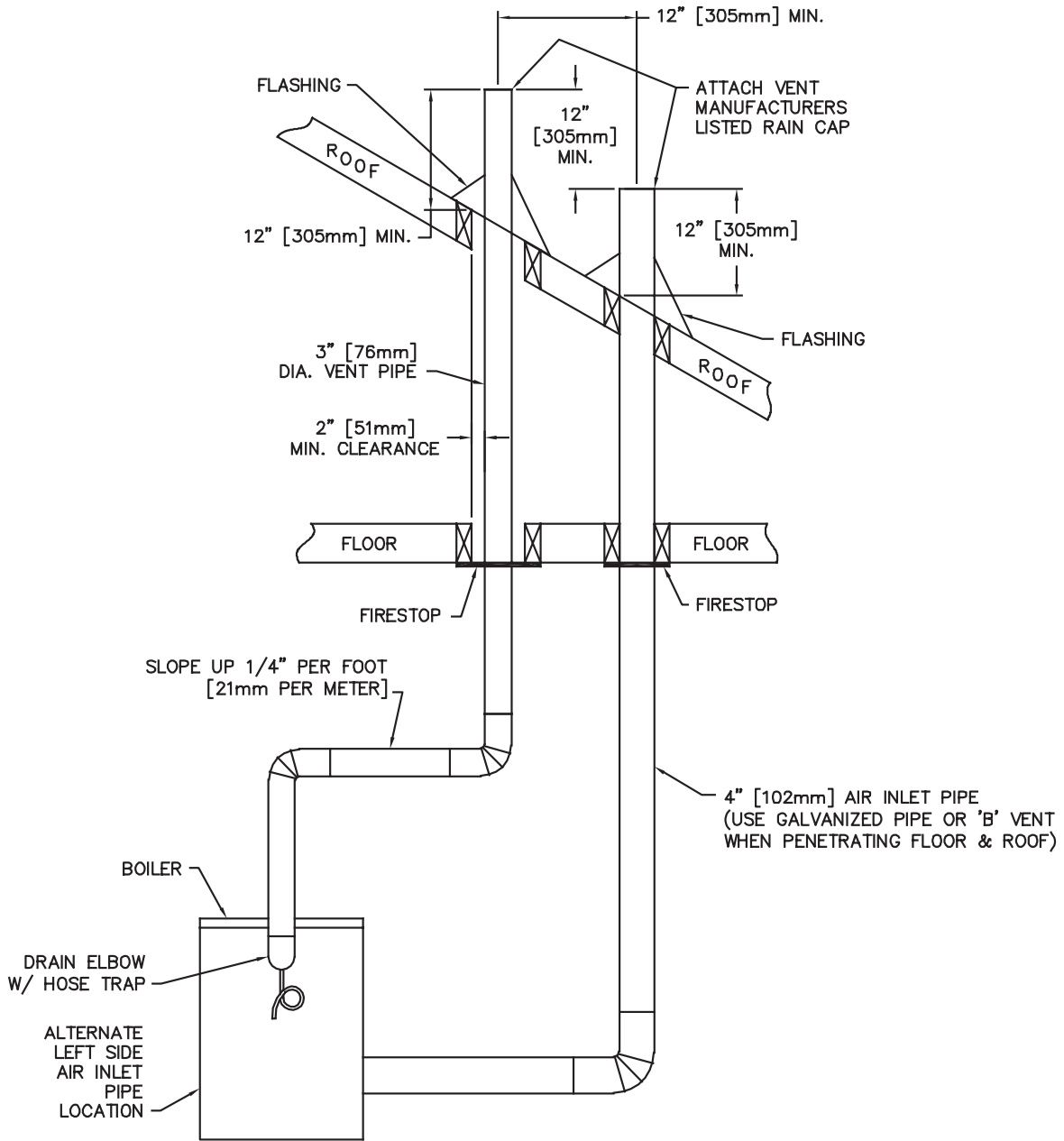

Figure 4.3: Vertical Venting System

F. AIR INLET PIPE INSTALLATION

1. For maximum air inlet pipe lengths see Table 4.2.
2. Use only 4" (102 mm) diameter galvanized pipe or 4" (102 mm) diameter flexible aluminum vent for supplying combustion air to boiler inlet air box.
3. Boiler connection can be from either right or left side of boiler jacket. Determine which jacket side air inlet piping is to be routed and remove the 4-1/2" (114 mm) jacket knock-out.
4. Attach a 4" (102 mm) diameter 90 degree elbow to top of air box and connect air inlet piping.
5. Support air inlet piping using the same methods and requirements as shown in the previous section for vent pipe support.
6. Seal all connections using silicone.
7. To prevent condensation from forming on exposed portions of Wall Thimble and 4" (102 mm) diameter air inlet piping, wrap exposed areas with insulation.

G. AIR FOR VENTILATION

1. Provide air openings for adequate ventilation to prevent ambient boiler room temperature from exceeding 120°F (49°C) during boiler operation. This is to maintain all the boiler controls below maximum service temperatures. Openings should be fixed in the open position during operation.

H. BOILER REMOVAL FROM COMMON VENTING SYSTEM

At the time of removal of an existing boiler, follow these steps with each appliance remaining connected to the common venting system placed in operation, while the other appliances remaining connected to the common venting system are not in operation:

Au moment de retirer une chaudière existante, il est important de suivre les étapes suivantes pour chaque appareil raccordé au système d'évacuation commun qui sont en service, alors que les autres appareils demeurant raccordés au système d'évacuation commun ne sont pas en service:

- a. Seal any unused openings in the common venting system.
Sceller toute ouverture du système d'évacuation commun non utilisée.
- b. Visually inspect the venting system for proper size and horizontal pitch and determine there is no blockage or restriction, leakage, corrosion and other deficiencies which could cause an unsafe condition.
Effectuer un contrôle visuel du système d'évacuation pour vérifier la taille et la pente horizontale et s'assurer qu'il n'existe aucun blocage ou obstruction, fuite, corrosion ni tout autre problème pouvant menacer la sécurité.
- c. Insofar as is practical, close all building doors and windows and all doors between the space in which the appliances remaining connected to the common venting system are located and other spaces of the building. Turn on any clothes dryers and any appliance

not connected to common venting system. Turn on any exhaust fans, such as range hoods and bathroom exhausts, so they will operate at maximum speed. Do not operate a summer exhaust fan. Close fireplace dampers.

Dans la mesure du possible, fermer toutes les portes et fenêtres de l'immeuble ainsi que toutes les portes entre l'espace dans lequel les appareils qui demeurent raccordés au système d'évacuation commun se trouvent et le reste de l'immeuble. Mettre en marche les sècheuses et tout autre appareil non raccordé au système d'évacuation commun. Mettre en marche tous les ventilateurs aspirant, tels que les hottes de cuisinière et les ventilateurs de salle de bain, en les faisant fonctionner à vitesse maximum. Ne pas faire fonctionner les ventilateurs aspirant d'été. Fermer les registres de foyers.

- d. Place in operation the appliance being inspected. Follow the lighting instructions. Adjust thermostat so appliance will operate continuously.
Mettre en service l'appareil à inspecter. Suivre les instructions concernant l'allumage. Régler le thermostat afin que l'appareil fonctionne sans arrêt.
- e. Test for spillage at the draft hood relief opening after 5 minutes of main burner operation. Use the flame of a match or candle, or smoke from a cigarette, cigar, or pipe.

Vérifier toute fuite à l'orifice de décharge du coupe-tirage après que le brûleur ait fonctionné pendant 5 minutes. Utiliser la flamme d'une allumette ou d'une chandelle ou encore la fumée d'une cigarette, d'un cigare ou d'une pipe.

- f. After it has been determined that each appliance remaining connected to the common venting system properly vents when tested as outlined above, return doors, windows, exhaust fans, fireplace dampers and any other gas-burning appliance to their previous conditions of use.

Après avoir établi que les résidus de combustion de chaque appareil qui demeure raccordé au système commun sont adéquatement évacués lorsque soumis au test décrit ci-dessus, remettre en place les portes, fenêtres, portes intérieures, ventilateurs aspirants, registres de foyer et appareils fonctionnant au gaz.

- g. Any improper operation of the common venting system should be corrected so that the installation conforms with the current edition of the *National Fuel Gas Code*, ANSI Z223.1/NFPA 54 and/or CAN/CSA B149.1, *Natural Gas and Propane Installation Code*. When resizing any portion of the common venting system, the common venting system should be resized to approach the minimum size as determined using the appropriate tables in the *National Fuel Gas Code*, ANSI Z223.1/NFPA 54 and/or CAN/CSA B149.1, *Natural Gas and Propane Installation Code*.

Tout fonctionnement inadéquat du système d'évacuation commun doit être corrigé de manière à respecter les normes du **National Fuel Gas Code**, ANSI Z223.1/NFPA 54 et/ou des Codes d'installation CAN/ACG B149. Lorsqu'il est nécessaire de modifier les dimensions de toute portion du système d'évacuation commun, ces dernières doivent être modifiées de manière à respecter les dimensions minimums indiquées dans les tableaux du chapitre « Sizing of Category I Venting Systems » du **National Fuel Gas Code**, ANSI Z223.1/NFPA 54 ou des Codes d'installation CAN/ACG B149.

5. GAS PIPING

1. Size and install the gas supply piping properly in order to provide a supply of gas sufficient to meet the maximum demand without undue loss of pressure between the meter and the boiler.
2. Determine the volume of gas to be provided to the boiler in cubic feet per hour. To obtain this value, divide the Btu per hour rating (on the boiler rating plate) by the heating value of the gas in Btu per cubic feet. Obtain the heating value of the gas from the gas supplier. As an alternative, use Table 5.1 on the next page to obtain the volume of gas to be provided to the boiler.
3. Use the value obtained above as the basis for piping sizing. Size the gas piping in accordance with Table 5.2. Consult the *National Fuel Gas Code*, ANSI Z223.1/NFPA 54 and/or *CAN/CSA B149.1, Natural Gas and Propane Installation Code*.
4. Locate the drop pipe adjacent to, but not in front of the boiler.
5. Install a sediment trap. See Figure 5.1. Locate a tee in the drop pipe at same elevation as the gas inlet connection to the boiler. Extend the drop pipe to a pipe cap.
6. Install a ground joint union ahead of the gas control assembly to permit servicing of the control. Some local codes require an additional service valve when using the combination gas controls. If your code requires such a valve, a suggested location is shown in Figure 5.1.

WARNING

Use a pipe joint sealing compound that is resistant to the action of liquefied petroleum gas. A non-resistant compound may lose sealing ability in the presence of this gas, resulting in a gas leak and fire or explosion potential.

7. Check piping for leaks prior to placing the boiler in operation.
Use an approved gas detector, a non-corrosive leak detection fluid or other leak detection method. If leaks are found, turn off all gas flow and repair as necessary.

WARNING

When checking for leaks, do not use matches, candles, open flames or other methods that provide a source of ignition. This can ignite a gas leak, resulting in fire or explosion.

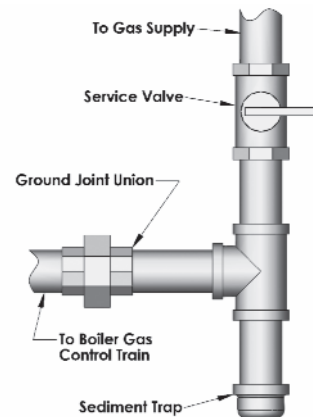

Figure 5.1: Gas Connection to Boiler

8. Disconnect the boiler and its individual shut-off valve from the gas supply piping system during any pressure testing of that system at test pressure in excess of 1/2 psig (3.5 kPa).

Isolate the boiler from the gas supply piping system by closing its individual service valve during any pressure testing of the gas supply piping system at test pressure equal to or less than 1/2 psig (3.5 kPa).

CAUTION

Do not subject the gas valve to more than 1/2 psi (3.5 kPa) pressure. Doing so may damage the valve.

9. Minimum permissible supply pressure for purposes of input adjustment (Inches Water Column):

Natural Gas	5.0" (1.2 kPa)
LP Gas	11.0" (2.7 kPa)

Maximum permissible supply pressure to the boiler (Inches Water Column):

Natural Gas	13.5" (3.4 kPa)
LP Gas	13.5" (3.4 kPa)

Table 5.1: Natural Gas

Boiler Model	Natural Gas Input		LP Gas Input	
	Cu. Ft/hr	Cu. Meter/hr	Cu. Ft/hr	Cu. Meter/hr
GVSC-03	65	1.8	26	0.7
GVSC-04	90	2.5	36	1.0
GVSC-05	120	3.4	48	1.4
GVSC-06	150	4.2	60	1.7

Table 5.2: Pipe Capacity

Capacity of pipe of different diameters and lengths in cubic feet per hour (cubic meter per hour) with pressure drop of 0.3 inches of water (75 Pa) and specific gravity of 0.60. No allowance for an ordinary number of fittings is required.

Pipe Length in Feet (Meters)	3/4" Pipe	1" Pipe	1-1/4" Pipe	1-1/2" Pipe
10 (3.0)	278 (7.9)	520 (14.7)	1050 (29.7)	1600 (45.3)
20 (6.1)	190 (5.4)	350 (9.9)	730 (20.7)	1100 (31.1)
30 (9.1)	152 (4.3)	285 (8.1)	590 (16.7)	890 (25.2)
40 (12.2)	130 (3.7)	245 (6.9)	500 (14.2)	760 (21.5)
50 (15.2)	115 (3.3)	215 (6.1)	440 (12.5)	670 (19.0)
60 (18.3)	105 (3.0)	195 (5.5)	400 (11.3)	610 (17.3)

Maximum Capacity Correction Factors for Specific Gravity other than 0.60.

Specific Gravity	0.50	0.55	0.60	0.65	0.70	0.75
Correction Factor	1.10	1.04	1.00	0.96	0.93	0.90
Specific Gravity	0.80	0.85	0.90	1.00	1.10	1.20
Correction Factor	0.87	0.84	0.82	0.78	0.74	0.71
Specific Gravity	1.30	1.40	1.50	1.60	1.70	1.80
Correction Factor	0.68	0.66	0.63	0.61	0.59	0.58

6. ELECTRICAL

Install all electrical wiring in accordance with the *National Electric Code* and local requirements.

⚠ NOTICE

This unit when installed must be electrically grounded in accordance with the requirements of the authority having jurisdiction or, in the absence of such requirements, with the current edition of the *National Electrical Code*, ANSI/NFPA 70 and/or the *Canadian Electrical Code*, Part 1, CSA C221.

A. WIRING

⚠ CAUTION

Label all wires prior to disconnection when servicing controls. Wiring errors can cause improper and dangerous operation. Verify proper operation after servicing.

⚠ AVERTISSEMENT

Identifier tous les câbles avant de les débrancher au moment d'effectuer l'entretien des commandes. Des erreurs dans le raccordement des câbles d'alimentation peuvent causer un fonctionnement inadéquat et dangereux. Vérifier le bon fonctionnement après les travaux d'entretien.

1. See Figure 6.1 for location of wiring and controls. Use Figure 6.2 to connect the boiler to a power supply and to connect components to the boiler.
2. Connect the boiler by a separate, permanently live electrical supply line with a fused switch.
3. Adjust the thermostat heat anticipator to 0.2 Amp.

B. ZONED SYSTEM WIRING

See Figure 6.4 for typical wiring with zone valves. See Figure 6.5 for typical wiring with zone circulators. When wiring a zoned heating system, follow all applicable codes, ordinances and regulations.

⚠ NOTICE

Do not power zone valves directly from the boiler transformer. Doing so will greatly reduce the life of the transformer. Use a separate transformer sized to handle the total of all zone valve electrical loads.

C. CONTROLS

1. For proper location of controls and accessories refer to Figure 6.1.
2. See the attached control sheets for specific details regarding the installation of the various controls.
3. This boiler is supplied with safety devices in addition to the limit. For a description of these devices and how they work to ensure the safe operation of the boiler, see Section 7.
4. If the circulator is mounted in the supply piping, provide longer wiring harness as required.

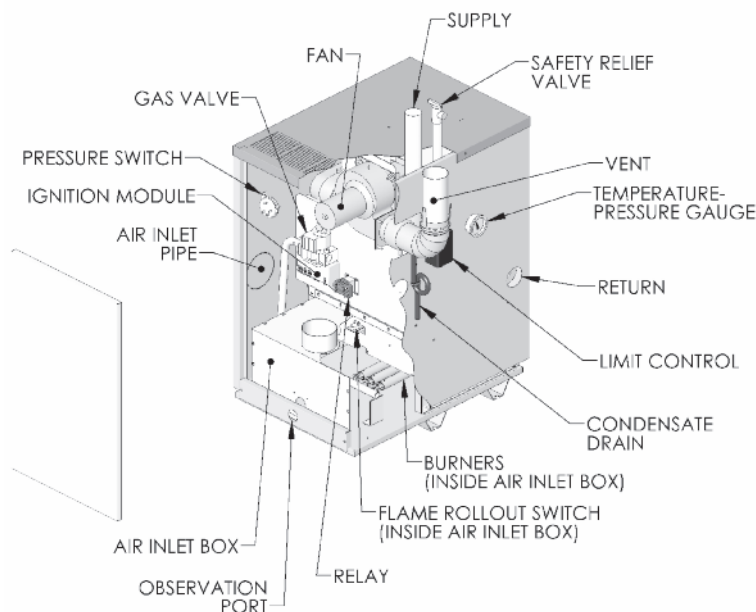

Figure 6.1: Wiring, Controls and Safety Devices

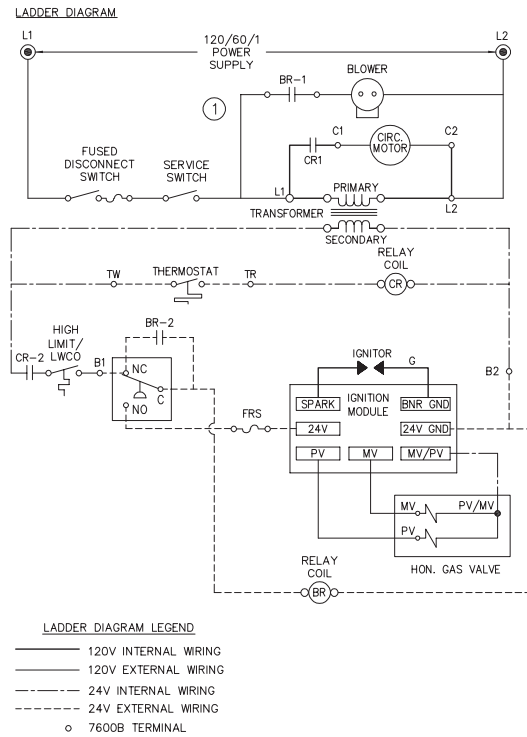
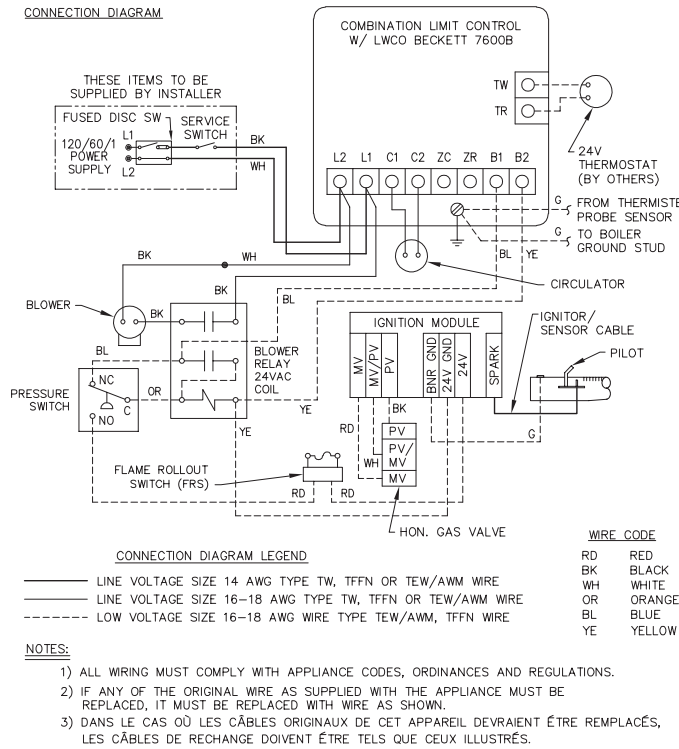

Figure 6.2: Wiring Diagram, Spark Ignited Pilot, Becket 7600 Limit Control

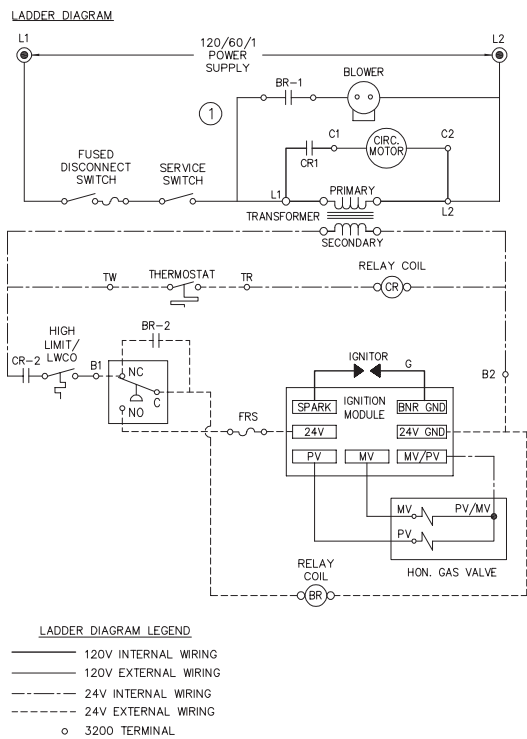
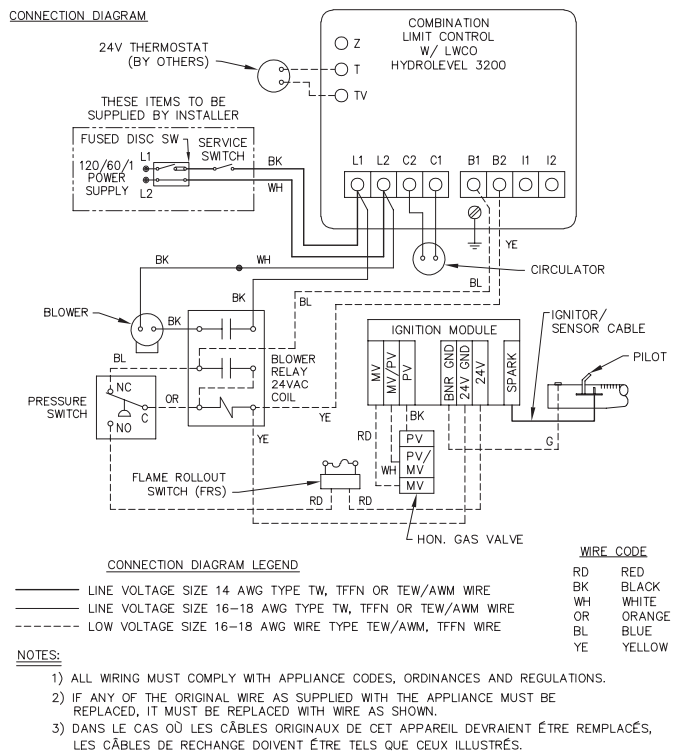

Figure 6.3: Wiring Diagram, Spark Ignited Pilot, Hydrolevel 3200 Limit control

D. BOILER SEQUENCE OF OPERATION

1. Thermostat calls for heat.
2. Limit control energizes circulator.
3. Limit control energizes B1 circuit if boiler water temperature is below setpoint minus differential. Setpoint is calculated according to thermostat cycle and economy/efficiency setting. See limit control literature for further information.
4. BR relay energizes blower.
5. Negative pressure induced by blower switches Pressure Switch, continuing power through closed contacts (BR-2) and flame roll-out switch.
6. Gas valve energizes.
 - a. Ignitor on.
 - b. Pilot gas on, igniting pilot

7. Pilot flame detected.
 - a. Ignitor off.
 - b. Main gas on, igniting main burners.

Note: If pilot flame is not detected within 90 seconds, the igniter and pilot are turned off for 5 minutes. The sequence then resumes at Step 6a.
8. Call for heat ends.
 - a. Pilot and main gas off, extinguishing pilot and main burners.
 - b. Blower and circulator off.

7. START-UP PROCEDURES**A. COMPLETING THE INSTALLATION**

1. Confirm that all water, gas and electricity are turned off.
2. Inspect the boiler combustion chamber for foreign objects and remove if present.
3. Check physical condition of burners and pilot. Make certain that there are no unusual bends or perforations in the burners or pilot. Replace components if necessary.
4. Verify that water piping, venting, gas piping and electrical wiring and components are installed properly. Refer back to previous sections of these instructions as well as equipment manufacturer's instructions as necessary.
5. Fill the boiler and system with water, making certain to vent all air from all points in the system. To check water level in the system, open and close each vent in the system. Water should exit from each vent when it is opened.
6. The pressure reducing valve on the fill line will typically allow the system to be filled and pressurized to 12 psi (83 kPa). Consult the valve and expansion tank manufacturer for more specific information.
7. Check joints and fittings throughout the system for leaks. If leaks are found, drain the system and repair as required.
8. Connect a manometer to the 1/8" NPT inlet pressure tap on the gas valve. See Figure 7.2.
9. Confirm that the gas supply pressure to the boiler is above the minimum and below the maximum values for the gas being used. See the end of Section 5 for these values. If a supply pressure check is required, isolate the boiler and gas valve before performing the pressure check. If the supply pressure is too high or too low, contact the gas supplier.
10. Turn on electricity and gas to boiler.
11. Light the boiler by following the Lighting/Operating Instructions label mounted to the jacket panel. The initial ignition may require several tries as the piping is purged of air.
12. Use the sequence description and Figure 6.3 in Section 6 (Electrical) to follow light-off and shutdown sequences and to assist in diagnosing problems. If the boiler does not function properly, consult Section 8, Troubleshooting.

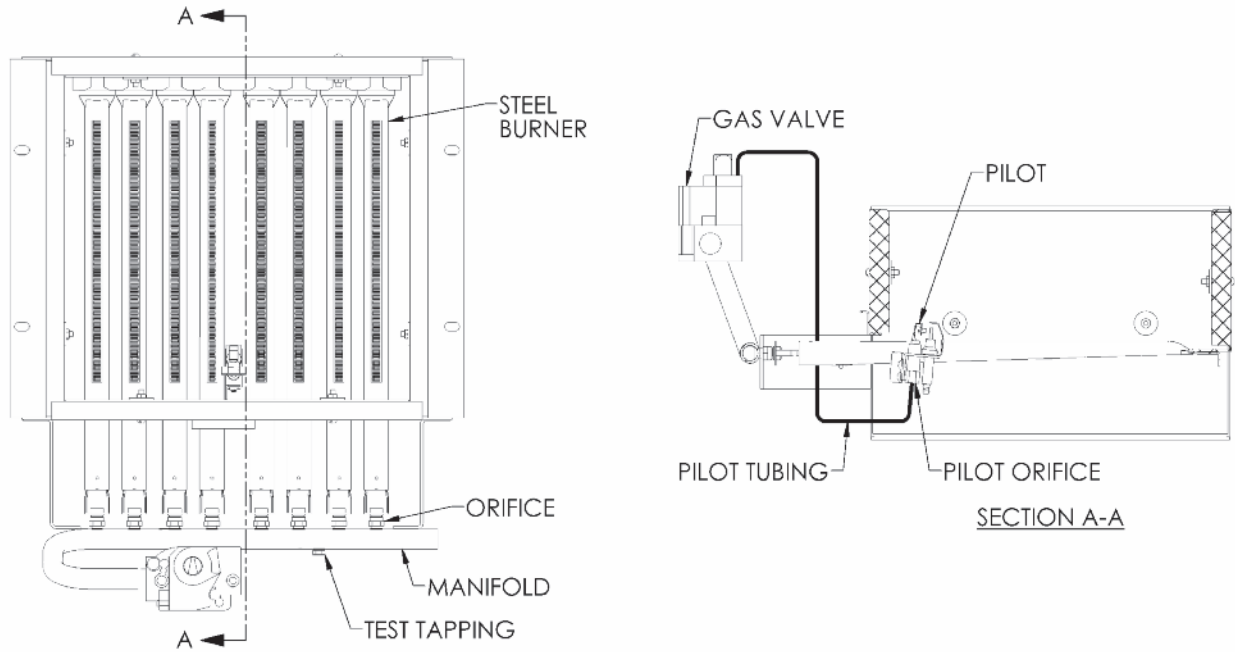

Figure 7.1: Gas Valve, Manifold and Burner Assembly – Intermittent Ignition

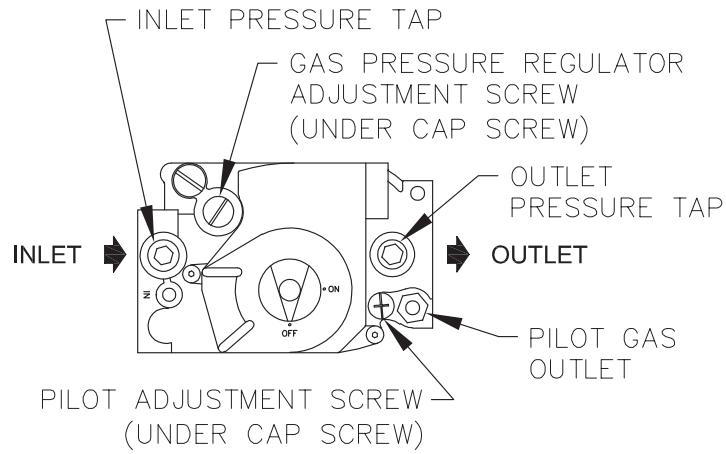

Figure 7.2: Valve Tapping and Adjustment Screw Locations

FOR YOUR SAFETY READ BEFORE LIGHTING

WARNING: If you do not follow these instructions exactly, a fire or explosion may result causing property damage, personal injury, or loss of life.

- A. This appliance is equipped with an ignition device which automatically lights the pilot. Do not try to light the pilot by hand.
 - B. **BEFORE OPERATING** smell all around the appliance area for gas. Be sure to smell next to the floor because some gas is heavier than air and will settle on the floor.
- WHAT TO DO IF YOU DO SMELL GAS**
- Do not try to light any appliance.
 - Do not touch any electric switch; do not use any phone in your building.
 - Immediately call your gas supplier from a neighbor's phone. Follow the gas supplier's instructions.
 - If you cannot reach your gas supplier, call the fire department.
- C. Use only your hand to push in or turn the gas control knob. Never use tools. If the knob will not push in or turn by hand, don't try to repair it, call a qualified service technician. Force or attempted repair may result in a fire or explosion.
 - D. Do not use this appliance if any part has been under water. Immediately call a qualified service technician to inspect the appliance and to replace any part of the control system and any gas control which has been under water.

OPERATING INSTRUCTIONS

1. **STOP!** Read the safety information above on this label.
2. Set the thermostat or operating control to lowest setting.
3. Turn off all electric power to the appliance.
4. This appliance is equipped with an ignition device which automatically lights the pilot. Do not try to light the pilot by hand.
5. If the gas valve is not visible, remove control access panel.
6. If the gas control knob is not in the "OFF" position, turn the knob clockwise ⤵ to "OFF".
7. Wait five (5) minutes to clear out any gas. Then smell for gas, including near the floor. If you smell gas, **STOP!** Follow "B" in the safety information above on this label. If you don't smell gas, go to the next step.
8. Turn the gas control knob counterclockwise ⤴ to "ON".
9. Replace control access panel, if applicable.
10. Turn on all electrical power to the appliance.
11. Set thermostat or operating control to desired setting.
12. If the appliance will not operate, follow the instructions "To Turn Off Gas To Appliance" and call your service technician or gas supplier.

Gas Control Knob
(shown in "OFF"
position)

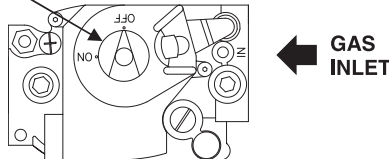

TO TURN OFF GAS TO APPLIANCE

1. Set the thermostat or operating control to lowest setting.
2. Turn off all electric power to the appliance if service is to be performed.
3. If the gas valve is not visible, remove the control access panel.
4. Turn the gas control knob clockwise ⤵ to "OFF".
5. Replace control access panel, if applicable.

HSP VR8204/VR8304 9181R REV 2 (MM/YY)

Figure 7.3: Operating Instructions

POUR VOTRE SÉCURITÉ, LISEZ AVANT L'ALLUMAGE

MISE EN GARDE: Négliger de suivre ces instructions à la lettre pourrait provoquer un incendie ou une explosion causant des dégâts matériels, des blessures ou la mort.

- A. Cet appareil est muni d'un dispositif d'allumage automatique de la veilleuse. Ne tentez pas d'allumer la veilleuse à la main.
- B. **AVANT DE METTRE EN MARCHÉ**, sentez autour de l'appareil pour détecter toute odeur de gaz. Etant donné que certains gaz sont plus lourds que l'air et se déposent sur le sol, s'assurer de bien sentir près du plancher.
- QUE FAIRE SI VOUS DÉTECTEZ UNE ODEUR DE GAZ**
- Ne pas tenter d'allumer l'appareil
 - Ne toucher à aucun interrupteur électrique; n'utiliser aucun appareil téléphonique dans l'immeuble.
 - Contactez immédiatement votre fournisseur de gaz à partir du téléphone d'un voisin. Suivre les instructions données par votre fournisseur de gaz.
- S'il est impossible de rejoindre le fournisseur de gaz, appeler le service des incendies.
- C. N'utilisez que votre main pour appuyer ou tourner le bouton de commande du gaz. Ne jamais utiliser d'outils. S'il est impossible d'enfoncer ou de tourner le bouton à la main, ne tentez pas de le réparer. Appelez un technicien d'entretien qualifié. Une force excessive ou une tentative de réparation peut provoquer un incendie ou une explosion.
- D. N'utilisez pas cet appareil ni aucune de ses pièces si elles ont été immergées. Contactez immédiatement un technicien d'entretien qualifié pour inspecter l'appareil et remplacer toute pièce du système de régulation du débit gazeux et toute commande de gaz ayant été immergée.

DIRECTIVES DE FONCTIONNEMENT

1. **ARRÊTEZ!** Lisez les consignes de sécurité plus haut sur cette étiquette.
2. Réglez le thermostat ou l'appareil de réglage au niveau le plus bas.
3. Coupez toute l'alimentation électrique de l'appareil.
4. Cet appareil est muni d'un dispositif d'allumage automatique de veilleuse. Ne tentez pas d'allumer la veilleuse à la main.

Bouton de contrôle du débit (illustré en position d'arrêt « OFF »)

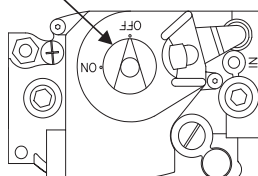

← ARRIVÉE DE GAZ

5. Si la soupape d'alimentation en gaz n'est pas visible, retirez le panneau d'accès.
6. Si le bouton de commande du gaz n'est pas en position « OFF », tournez le bouton dans le sens des aiguilles d'une montre U pour les mettre à « OFF ».
7. Attendez cinq (5) minutes pour que tout le gaz présent puisse s'échapper. Sentir autour de l'appareil pour détecter toute odeur de gaz, incluant près du sol. Si vous sentez une odeur de gaz, **ARRÊTEZ!** Suivez les consignes de sécurité apparaissant en « B » plus haut sur cette étiquette. Si vous ne détectez aucune odeur de gaz, passez à l'étape suivante.
8. Tournez le bouton de commande dans le sens contraire des aiguilles d'une montre U pour le mettre en position de marche « ON ».
9. Remplacez le panneau d'accès du régulateur de débit, le cas échéant.
10. Remettez en marche toute l'alimentation électrique de l'appareil.
11. Réglez le thermostat ou l'appareil de réglage au niveau désiré.
12. Si l'appareil ne se met pas en marche, suivez les instructions ci-dessous : « Couper l'alimentation en gaz de l'appareil » et appelez votre technicien d'entretien ou fournisseur de gaz.

COUPER L'ALIMENTATION EN GAZ DE L'APPAREIL

1. Réglez le thermostat ou l'appareil de réglage au niveau le plus bas.
2. Si des travaux d'entretien doivent être effectués, couper toute l'alimentation électrique de l'appareil.
3. Si la soupape d'alimentation en gaz n'est pas visible, retirez le panneau d'accès.
4. Tournez le bouton de commande dans le sens des aiguilles d'une montre U pour les mettre en position d'arrêt « OFF ».
5. Remplacez le panneau d'accès du régulateur de débit, le cas échéant.

HSP VR8204/VR8304 9414 REV 0 (MM/AA)

Figure 7.4: Operating Instructions

B. CONTROL DESCRIPTIONS

See Figure 6.1 in Section 6 (Electrical) for locations of these devices.

1. **FLAME ROLL-OUT SAFETY SHUT-OFF SWITCH (FLAME ROLL-OUT SWITCH)** – A thermally activated switch located between the first burner from the left and the manifold bracket. The flame roll-out safety shut-off switch will sense excessive temperature caused by continued flame roll-out and shut down main burner gas. This is a non-recycling switch that must be replaced once it has been activated and the cause of the roll-out eliminated.
2. **DIFFERENTIAL PRESSURE SWITCH** – This device senses a negative or suction pressure in the blower housing and air box when the blower is energized. If there is not excessive blockage in the venting system or air inlet vent the switch will close, allowing power to energize the ignition system.
3. **LIMIT WITH LOW WATER CUT-OFF**– A Beckett 7600B or Hydrolevel 3200 control incorporate a thermally activated adjustable switch that will shut down main burner gas if the supply water temperature exceeds the control setting It will also shut down main burner gas if the water level in the boiler drops below the control’s sensing well. The temperature switch will automatically reset when the boiler supply water temperature drops below the control setpoint. The low water cut-off switch will automatically reset when the water level is above the control’s sensing well.
4. **LOW WATER CUT-OFF (FOR GRAVITY SYSTEMS OR HOT WATER BOILERS INSTALLED ABOVE RADIATION LEVEL)** – A level-sensing device (float or probe) located in supply piping near the boiler. If water level in the system drops below the control’s position, it will shut down main burner gas. The control will automatically reset once the water level rises above its position.

C. ADJUSTMENT OF GAS PRESSURE REGULATOR

1. Move the manometer to either the outlet pressure tap on the gas valve or to the burner manifold test tap. Set manifold pressure as follows for various gases.
 - a. Natural Gas3.5" Water Column (0.9 kPa)
 - b. LP Gas10.0" Water Column (2.5 kPa)
2. To adjust gas pressure, turn adjusting screw of gas pressure regulator counterclockwise to decrease pressure, clockwise to increase pressure. Refer to Figure 7.2 for location of gas pressure regulator. Replace the cap screw when adjustment is complete.
3. In no case should the final manifold pressure vary more than ±0.3 inches water column (0.07 kPa) from the above specified pressures. Any necessary major changes in the flow should be made by changing the size of the burner orifice spuds.
4. When adjustment is complete, turn off boiler, gas flow and electricity to boiler. Remove manometer and plug tapping with plug provided. Turn utilities back on and resume checkout.

D. CHECKING BURNER INPUT

1. Refer to rating label mounted on the jacket top panel to obtain the rated BTU per hour input. In no case shall the input to the boiler exceed the value shown on the rating label.
2. Check input by use of the following formula (Smith suggests reading meter for 2 Cu.Ft. [0.0566 cubic meter]):

U.S. Customary Units:

$$\text{Input (BTU/Hr.)} = \frac{3600 \times F \times H}{T}$$

Where:
 3600 – Seconds per hour
 F – Cubic Feet of Gas Registered on Meter
 H – Heat Value of Gas in BTU/Cubic Feet
 T – Time in Seconds the Meter is Read

SI Metric Units

$$\text{Input (kW)} = \frac{3600 \times F \times H}{T \times 3.6}$$

Where:
 3600 – Seconds per hour
 3.6 – Megajoule (MJ) per kilowatt hour (kWhr)
 F – Cubic Meters of Gas Registered on Meter
 H – Heating Value of Gas in MJ/Cubic Meter
 T – Time in Seconds the Meter is Read

3. As an alternative, use Table 7.1a and 7.1b. Use the heating value provided by gas supplier. Use a stopwatch to record the time it takes for 2 cubic feet (0.0566 cubic meter) of gas to pass through the meter. Read across and down to determine rate.

E. CHECK-OUT PROCEDURE

1. After starting the boiler, be certain all controls are working properly. Check to be sure that the limit will shut off the boiler in the event of excessive water temperature. This can be done by lowering the limit setting until the main burners shut down. When proper limit function is confirmed, return the dial to its previous setting.
2. To check operation of the ignition system safety shut-off features:
 - a. Turn gas supply off.
 - b. Set thermostat or controller above room temperature to call for heat. Watch for igniter spark at pilot burner.
 - c. Igniter will continue to spark for 90 seconds. It will then de-energize for 5 minutes before restarting the sequence.
 - d. Turn gas supply on.
 - e. Reset the boiler and control by following Operating Instructions.
 - f. Observe boiler operation through one complete cycle.

START-UP PROCEDURES

Table 7.1a: Meter Conversion Natural Gas (U.S. Customary Units)

Burner inputs in Btu/hr for various meter timings and heating values. (Tables based on 2 cubic feet of gas through the meter).

Time that meter is read (sec)	Heat Value of Gas (Btu/cubic foot)		
	1000	1025	1050
25	288000	295200	302400
30	240000	246000	252000
35	205714	210857	216000
40	180000	184500	189000
45	160000	164000	168000
50	144000	147600	151200
55	130909	134182	137455
60	120000	123000	126000
65	110769	113538	116308
70	102857	105429	108000
75	96000	98400	100800
80	90000	92250	94500
85	84706	86824	88941
90	80000	82000	84000
95	75789	77684	79579
100	72000	73800	75600
105	68571	70286	72000
110	65455	67091	68727
115	62609	64174	65739
120	60000	61500	63000
125	57600	59040	60480

Table 7.1b: Meter Conversion Natural Gas (SI Metric System)

Burner inputs in kW for various meter timings and heating values. (Tables based on 0.0566 cubic meters of gas through the meter).

Time that meter is read (sec)	Heat Value of Gas (MJ/cubic meter)		
	37.26	38.19	39.12
25	84.36	86.46	88.57
30	70.30	72.05	73.81
35	60.25	61.76	63.26
40	52.72	54.04	55.35
45	46.86	48.03	49.20
50	42.18	43.23	44.28
55	38.34	39.30	40.26
60	35.15	36.03	36.90
65	32.44	33.25	34.06
70	30.13	30.88	31.63
75	28.12	28.82	29.52
80	26.36	27.02	27.68
85	24.81	25.43	26.05
90	23.43	24.02	24.60
95	22.20	22.75	23.31
100	21.09	21.62	22.14
105	20.08	20.59	21.09
110	19.17	19.65	20.13
115	18.34	18.80	19.25
120	17.57	18.01	18.45
125	16.87	17.29	17.71

- Low Water Cut-Off (if used) – Consult the manufacturer's instructions for the low water cut-off operational check procedure.
- Check the system to make sure there are no leaks or overfilling problems which might cause excessive make-up water to be added. Make-up water causes liming in the boiler and brings in oxygen. Oxygen can cause severe damage to the boiler through oxygen corrosion pitting.
- Check the expansion tank and automatic fill valve (if used) to confirm that they are operating correctly. If either of these components causes high pressure in the system, the boiler relief valve will weep or open, allowing fresh water to enter the system.
- Do not allow the system controls to subject the boiler to excessively low water temperatures, which would cause condensation of flue gases and corrosion of the boiler. Operate the boiler at a temperature above 130°F (54°C). Adjust the boiler limit as required to maintain boiler temperature above this level.
- Check the general condition of the system including piping support, joints, etc. Check cleanliness of the radiators, baseboard units and/or convectors. Clean them to the extent possible. If radiators do not heat evenly, vent any remaining air from them.
- Review operation and User's Information Manual with end-user.
- Hang the Installation, Operation and Maintenance Manual, User's Information Manual, and Vent Manufacturer's Information Manual in an accessible position near the boiler.

8. TROUBLESHOOTING

A. SHUT-DOWN CAUSED BY PILOT OUTAGE, PRESSURE SWITCH OR FLAME ROLL-OUT SAFETY SHUT-OFF SWITCH

In the event of a shut-down caused by a pilot outage, action of the pressure switch or flame roll-out safety shut-off switch effecting a shut-down of the main burners:

- Refer to the Lighting/Operating Instructions in Figure 7.3 to properly turn off the gas to the boiler.
- Turn off all electric power to the boiler.
- Call a qualified heating service organization or local gas company and have the cause of the shut-down investigated and corrected.
- Refer to Operating Instructions to re-start boiler.

B. TROUBLESHOOTING GUIDES

Use Table 8.1 and Figure 8.2 to assist in determining causes and providing corrective actions to boiler problems. These guides must be used only by qualified service technicians. These individuals must follow all applicable codes and regulations in repair of any boiler problems.

C. MEASURING SUCTION PRESSURE

Pressure switch requires minimum $-0.45''$ W.C. (-112 Pa) fan suction pressure to energize control circuit. Measure when boiler has been operating at least 15 minutes. See Figure 8.1.

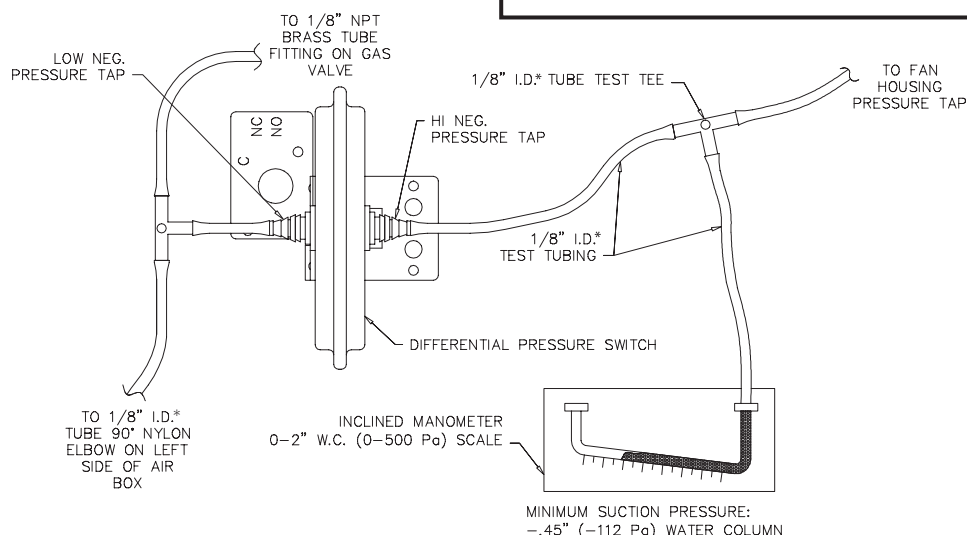

*1/8" I.D. IS APPROXIMATELY EQUIVALENT TO 3 MILLIMETERS.

Figure 8.1: Measuring Fan Suction Pressure

⚠ DANGER

When servicing or replacing items that communicate with the boiler water, be certain that:

- There is no pressure on the boiler.
- The boiler is not hot.
- The power is off.

When servicing the gas valve or pilot, be certain that:

- The gas is off.
- The electricity is off.

⚠ WARNING

Do not use this appliance if any part has been under water. Improper or dangerous operation may result. Immediately call a qualified service technician to inspect the boiler and to replace any part of the control system and any gas control which has been under water.

⚠ CAUTION

Label all wires prior to disconnection when servicing controls. Wiring errors can cause improper and dangerous operation. Verify proper operation after servicing.

⚠ CAUTION

Should overheating occur or the gas supply fail to shut off, do not turn off or disconnect the electrical supply to the pump. This may aggravate the problem and increase the likelihood of boiler damage. Instead, shut off the gas supply at a location external to the appliance.

Table 8.1: Boiler Troubleshooting Guide (Burners Functioning)

Problem	Possible Causes	Corrective Actions
Burners not functioning, blower running.	<ol style="list-style-type: none"> 1. Flame rollout switch open. 2. Pressure switch in closed position. 3. Ignition system problem. 	<ol style="list-style-type: none"> 1. Replace switch. Locate cause and correct. 2a. Check for plugged or damaged switch tubing. 2b. See Section "Measuring Suction Pressure" in boiler manual. If adequate, replace pressure switch. If inadequate, check for blockage or leak in vent system. If ok, replace blower. 3a. See ignition system troubleshooting guide below. 3b. See ignition system manufacturer literature for instructions including key to control LED lamp diagnostics.
Burners not functioning, blower not running.	<ol style="list-style-type: none"> 1. No power. 2. Water Temperature below calculated setpoint minus differential. 3. Limit Control not working. 	<ol style="list-style-type: none"> 1. Check line voltage wiring and fuses. 2a. Wait for calculated setpoint to rise / boiler temperature to fall. 2b. Adjust efficiency/economy setting. See limit control manufacturer's literature. 3. Check wiring and contacts, relay, temperature setting. Clean and adjust as necessary.
Burners will not shut down.	<ol style="list-style-type: none"> 1. Defective gas valve. 2. Short circuit. 	<ol style="list-style-type: none"> 1. See ignition system troubleshooting guide below to troubleshoot gas valve. Replace if necessary. 2. Check and correct wiring.
Flashback or burning at orifice spuds.	<ol style="list-style-type: none"> 1. Manifold gas pressure too low. 2. Improperly sized/drilled orifice spuds. 3. Leaking gas valve. 4. Burrs on orifice. 5. Low supply gas pressure. 6. Draft problems in boiler room. 	<ol style="list-style-type: none"> 1. Adjust to proper pressure. 2. Install correct spuds. 3. Replace valve. 4. Remove burrs. 5. Contact gas supplier if natural gas. 6. Check air supply, ventilation and venting system.
Delayed ignition.	<ol style="list-style-type: none"> 1. Insufficient pilot flame. 2. Pilot burner/orifice clogged. 3. Overfiring. 4. Misaligned burners or pilot. 5. Draft problem in boiler room. 	<ol style="list-style-type: none"> 1. Increase pilot gas flow. 2. Clean pilot burner and orifice. 3. Reduce rate to input on rating label. 4. Realign burners or pilot. 5. Check air supply, ventilation and venting system.
Boiler not heating properly.	<ol style="list-style-type: none"> 1. Underfiring. 2. Limit set too low. 3. Air in system. 4. Circulator malfunctioning. 5. Circulation system clogged. 6. Incorrect thermostat heat anticipator setting. 	<ol style="list-style-type: none"> 1. Increase rate to input on rating label. 2. Reset Aquastat to higher setting. 3. Vent air from all points in system. 4. Check circulator, replace if necessary. 5. Shut down and cool boiler, drain and flush system. 6. Adjust heat anticipator.
Fumes or gas odors.	<ol style="list-style-type: none"> 1. Leaks in gas piping or fittings. 2. Leaks in gas service line or meter. 3. Obstructed flueways or vent. 4. Draft problem in boiler room. 5. Overfiring. 	<ol style="list-style-type: none"> 1. Locate and repair or replace. 2. Shut down boiler and notify gas provider. 3. Clean flueways or vent and remove obstructions. 4. Check air supply, ventilation and venting system. 5. Reduce rate to input on rating label.

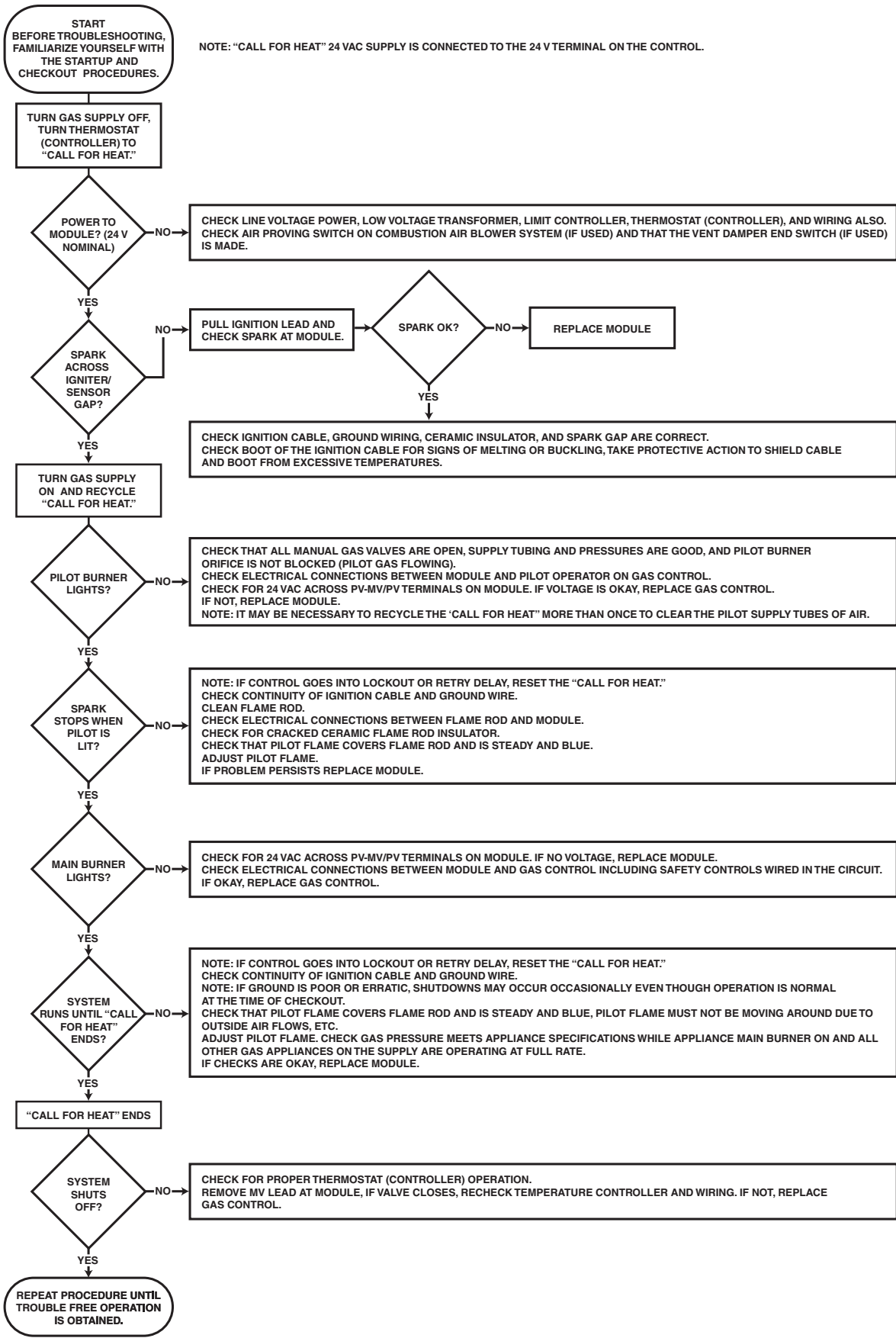

Figure 8.2: Intermittent Ignition System Troubleshooting Sequence

9. MAINTENANCE

WARNING

Product Safety Information Refractory Ceramic Fiber Product

This appliance contains materials made from refractory ceramic fibers (RCF). Airborne RCF, when inhaled, have been classified by the International Agency for Research on Cancer (IARC), as a possible carcinogen to humans. After the RCF materials have been exposed to temperatures above 1800°F (980°C), they can change into crystalline silica, which has been classified by the IARC as carcinogenic to humans. If particles become airborne during service or repair, inhalation of these particles may be hazardous to your health.

Avoid Breathing Fiber Particulates and Dust

Suppliers of RCF recommend the following precautions be taken when handling these materials:

Precautionary Measures:

Provide adequate ventilation.

Wear a NIOSH/MSHA approved respirator.

Wear long sleeved, loose fitting clothing and gloves to prevent skin contact.

Wear eye goggles.

Minimize airborne dust prior to handling and removal by water misting the material and avoiding unnecessary disturbance of materials.

Wash work clothes separately from others. Rinse washer thoroughly after use.

Discard RCF materials by sealing in an airtight plastic bag.

First Aid Procedures:

Inhalation: If breathing difficulty or irritation occurs, move to a location with fresh clean air. Seek immediate medical attention if symptoms persist.

Skin Contact: Wash affected area gently with a mild soap and warm water. Seek immediate medical attention if irritation persists.

Eye Contact: Flush eyes with water for 15 minutes while holding eyelids apart. Do not rub eyes. Seek immediate medical attention if irritation persists.

Ingestion: Drink 1 to 2 glasses of water. Do not induce vomiting. Seek immediate medical attention.

A. GENERAL

1. Disconnect this boiler from the gas supply piping during any pressure testing of the gas system.
2. Check pipes adjacent to cold walls or in unheated spaces. Insulate and tape them if necessary to be sure they can't freeze up. Keeping the water moving at all times will reduce the likelihood of freezing. See Section 3 for antifreeze instructions.
3. If there is considerable foreign matter in the boiler water, the boiler should be shut down and allowed to cool, then drained and thoroughly flushed out. Use the drain valve at the bottom of the return connection to drain the boiler. Pipe the drain cock to a suitable drain or containment device if antifreeze is used. Flush the system to remove remaining matter. If there is evidence that hard scale has formed on the internal surfaces, the boiler should be cleaned by chemical means as prescribed by a qualified water treatment specialist.

B. DAILY (WITH BOILER IN USE)

Daily boiler observation can be performed by the owner. If any potential problems are found, a qualified installer or service technician/agency must be notified.

1. Remove any combustible materials, gasoline and other flammable liquids and substances that generate flammable vapors from the area where the boiler is contained. Make certain that the boiler area has ample air for ventilation and that there are no obstructions to the free flow of air to and from the boiler.
2. Observe general boiler conditions (unusual noises, vibrations, etc.)
3. Observe operating temperature and pressure on the combination gauge located on the right side of the boiler. Boiler pressure should never be higher than 5 psi (35 kPa) below the rating shown on the safety relief valve (25 psig [172 kPa] maximum for a 30 psig [207 kPa] rating, 45 psig [310 kPa] maximum for a 50 psig [345 kPa] rating). The valve rating can be found on the top of the safety relief valve (see Figure 3.4 for location of the safety relief valve). Boiler temperature should never be higher than 250°F (121°C).
4. Check for water leaks in boiler and system piping.
5. Smell around the appliance area for gas. If you smell gas, follow the procedure listed in the Operating Instructions to shut down appliance in Figure 7.3.

C. WEEKLY (WITH BOILER IN USE)

1. Flush float-type low-water cut-off (if used) to remove sediment from the float bowl as stated in the manufacturer's instructions.

D. MONTHLY (WITH BOILER IN USE)

1. Verify condensate drain trap (loop) has sufficient water to maintain seal and is not blocked. Fill and/or unblock as necessary.
2. Check boiler room floor drains for proper functioning.
3. Check function of the safety relief valve (monthly unless specified otherwise by manufacturer) by performing the following test:
 - a. Check valve piping to determine that it is properly installed and supported.
 - b. Check boiler operating temperature and pressure.
 - c. Lift the try lever on the safety relief valve to the full open position and hold it for at least five seconds or until clean water is discharged.
 - d. Release the try lever and allow the valve to close. If the valve leaks, operate the lever two or three times to clear the valve seat of foreign matter. It may take some time to determine if the valve has shut completely.
 - e. If the valve continues to leak, it must be replaced before the boiler is returned to operation.
 - f. Check that operating pressure and temperature have returned to normal.
 - g. Check again to confirm that valve has closed completely and is not leaking.
4. Test low-water cut-off (if used) as described by the manufacturer.
5. Test limit as described in Section 7, "Check-Out Procedure."
6. Test function of gas safety shut-off features as described by gas valve and ignition control manufacturer.

 DANGER

When servicing or replacing components, be absolutely certain that the following conditions are met:

- **Water, gas and electricity are off.**
- **The boiler is at room temperature.**
- **There is no pressure in the boiler.**

E. ANNUALLY (BEFORE START OF HEATING SEASON)

1. Inspect flueways, burners and vent system. See Figure 9.2.
 - a. Refer to the Operating Instructions in Figure 7.3 to properly turn off the gas to the boiler. Turn off all electrical power to the boiler.
 - b. Remove jacket removable door, air inlet pipe, air box cover, and air box diffuser screen.

- c. Remove burner hitch pin clips. Disconnect pilot tubing at compression elbow.
- d. Disconnect pilot harness at gas valve. Gently pull pilot harness further inside air box to be able to remove burner with attached pilot.
- e. Remove burners and pilot.
- f. Brush gas outlet ports lightly using a soft bristle brush. If extensive corrosion in outlet ports, replace.
- g. Examine pilot hood and igniter for corrosion, scale, ceramic cracking. Replace if necessary.
- h. Remove 3" (76 mm) diameter vent pipe at condensate elbow or fan outlet.

- r. Examine air box cover seal. Reposition/replace as necessary to assure air tight seal.
- s. Reinstall air box cover.

WARNING

Soot accumulation indicates boiler malfunction. Cause of malfunction must be determined and corrected before returning boiler to service.

- i. Remove top jacket panel, flue collector/fan assembly, and flue baffles.
- j. Examine flueways and flue collector/fan for scale, soot, and loose rust.
- k. If necessary, brush flueways with wire brush and remove scale and loose rust from flue baffles. If corroded, replace baffles.
- l. Reinstall flue baffles.
- m. Examine flue collector blanket seal. Reposition/replace as necessary to assure air tight seal between flue collector and heat exchanger.
- n. Reinstall flue collector/fan assembly.
- o. Reinstall jacket top panel.
- p. Reinstall pilot, burners, hitch pin clips. Reconnect pilot harness to gas valve, gently pulling harness to length required to reach gas valve.
- q. Reinstall air box diffuser.

WARNING

Leaks in the vent system will cause products of combustion to enter structure (vent system operates under positive pressure).

- t. Examine entire vent system for corrosion, support and joint integrity. Repair as necessary. Remove any debris inside vent.
- u. Reconnect vent pipe to fan adapter. Reseal using high-temp silicones as shown in Section 4, Venting, Ventilation and Air Inlet.
- v. Refer to Operating Instructions in Figure 7.3 to properly return the boiler to operation.

2. Check the pilot and main burner flame. See Figure 9.1. The pilot should provide a steady flame enveloping 3/8" to 1/2" (1 cm to 1.2 cm) of the flame sensor. If required, adjust the pilot as stated in the gas valve manufacturer's instructions. The main burner flame inner cone should be approximately 1-1/2" (4 cm) high and should have a very sharp, blue color characteristic.

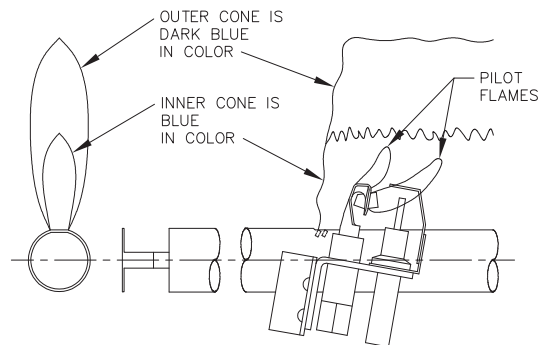

Figure 9.1: Intermittent Pilot and Main Burner Flame

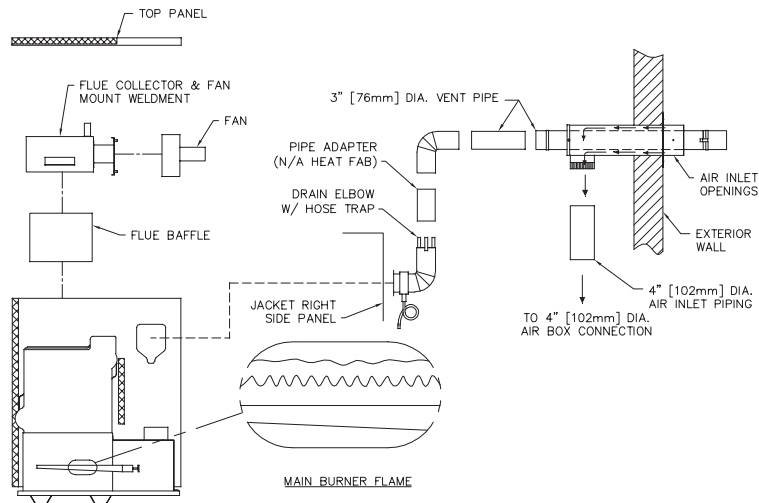

Figure 9.2: Inspection of Flueways, Burners, and Vent System.

10. BOILER DIMENSIONS & RATINGS

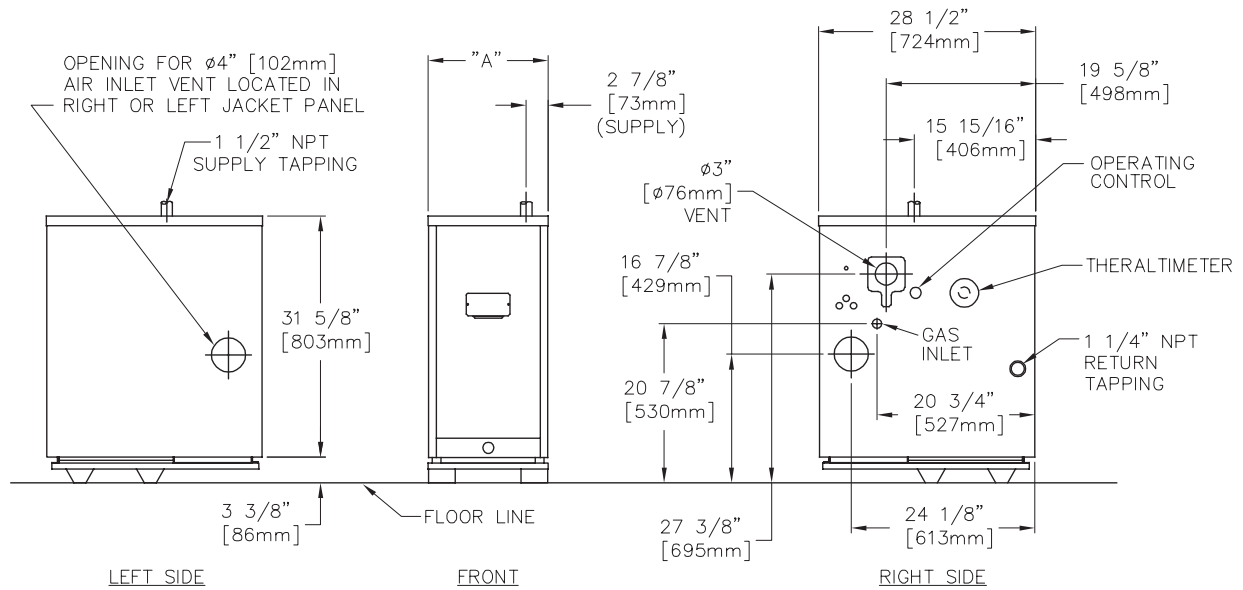

Figure 10.1: Boiler Views

Table 10.1: Series GVSC Boiler Dimensions

SERIES GVSC BOILER DIMENSIONS		
Boiler Model Number	Jacket Width "A"	
	GVSC-03	12-1/2"
GVSC-04	15-7/8"	403 mm
GVSC-05	19-1/4"	489 mm
GVSC-06	22-5/8"	575 mm

Table 10.2: Series GVSC Boiler Ratings

SERIES GVSC BOILER RATINGS											
Series GVSC								Water Content			
Boiler Model Number	Input		DOE Heating Capacity ³		Net Ratings Water ^{1,2}		Seasonal Efficiency ³ AFUE			Gallon	Liter
	MBH	kW	MBH	kW	MBH	kW	%				
GVSC-03	65	19	56	16	49	14	86.0	4.72	17.87		
GVSC-04	90	26	77	23	67	20	85.0	6.00	22.71		
GVSC-05	120	35	102	30	89	26	85.0	7.28	27.56		
GVSC-06	150	44	128	37	111	32	85.1	8.56	32.40		

1 Net water ratings based on an allowance of 1.15.

2 Consult factory before selecting a boiler for installations having unusual piping and pickup requirements, such as intermittent system operation, extensive piping systems, etc.

3 Heating Capacity and Annual Fuel Utilization Efficiency (AFUE) ratings are based on U.S. Government test.

11. REPAIR PARTS

REPAIR PARTS GVSC GAS BOILER

Repair parts are available from your local Smith distributor.

Note: Remember to include the boiler model number and serial number when ordering parts.

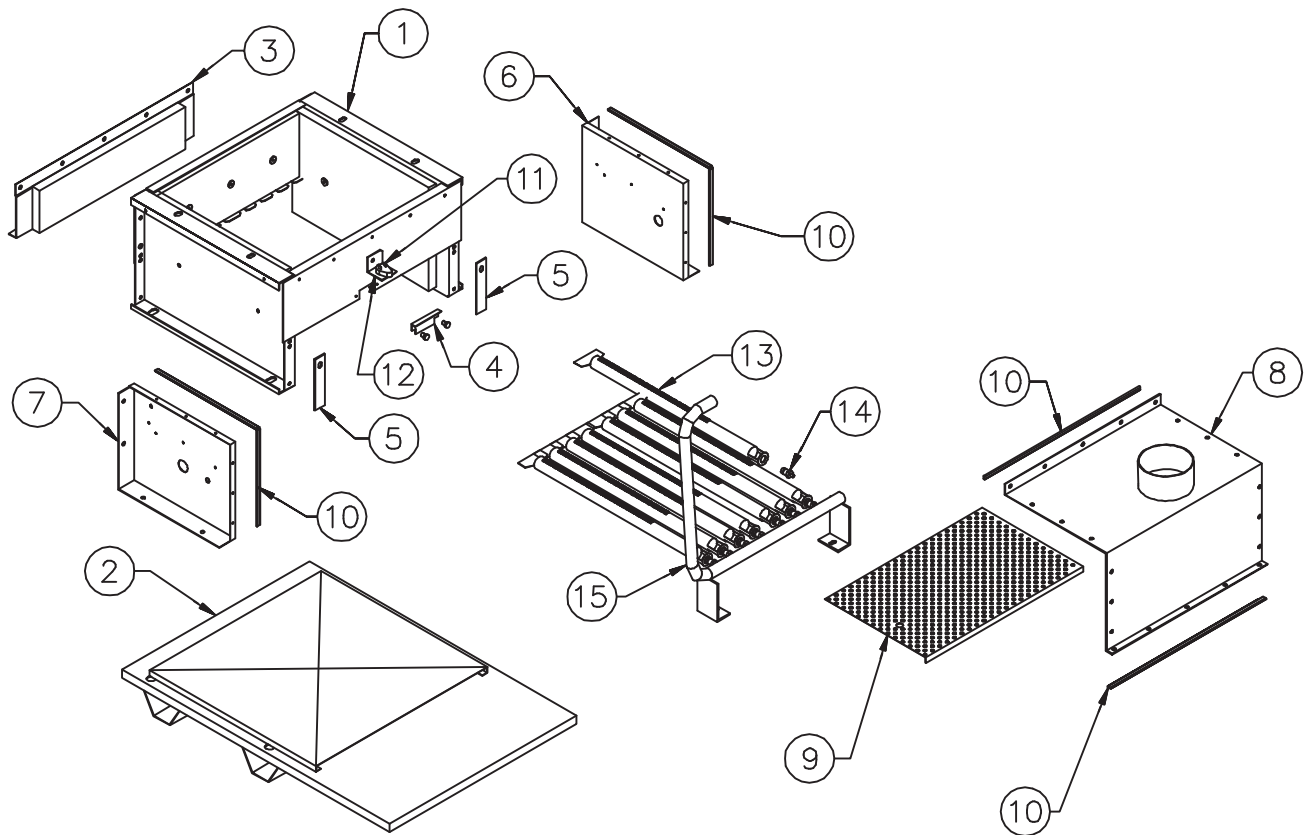

Figure 11.1

Table 11.1: Repair Parts

	Description	Quantity Required	Stock Code
1	Base Assembly – GVSC-03	–	7800
	Base Assembly – GVSC-04	–	7801
	Base Assembly – GVSC-05	–	7802
	Base Assembly – GVSC-06	–	7803
2	Floor Pan – GVSC-03	–	50100
	Floor Pan – GVSC-04	–	50101
	Floor Pan – GVSC-05	–	50102
	Floor Pan – GVSC-06	–	50103
3	Base Rear Panel Assembly – GVSC-03	–	PSC2000
	Base Rear Panel Assembly – GVSC-04	–	PSC2000-1
	Base Rear Panel Assembly – GVSC-05	–	PSC2000-2
	Base Rear Panel Assembly – GVSC-06	–	PSC2000-3
4	Base Observation Port Cover	–	51771
5	Base/Air Box Spacer – 92	2	50152
6	Air Box Right Side	–	PSC2023
7	Air Box Left Side	–	PSC2024
8	Air Box Top/Front Cover – GVSC-03	–	50143
	Air Box Top/Front Cover – GVSC-04	–	50144
	Air Box Top/Front Cover – GVSC-05	–	50145
	Air Box Top/Front Cover – GVSC-06	–	50146
9	Air Box Diffuser Screen – GVSC-03	–	PSC2025
	Air Box Diffuser Screen – GVSC-04	–	PSC2025-1
	Air Box Diffuser Screen – GVSC-05	–	PSC2025-2
	Air Box Diffuser Screen – GVSC-06	–	PSC2025-3
10	Rope Gasket Seal, Air Box	–	50718
11	Flame Rollout Switch, Thermodisc G4AM00_167C	–	51587
12	Flame Rollout Switch Bracket	–	50136
13	Steel Burner – GVSC-03	3	51536
	Steel Burner – GVSC-04	5	51536
	Steel Burner – GVSC-05	7	51536
	Steel Burner – GVSC-06	9	51536
–	Burner with Pilot Bracket	–	51535
14	Orifice, #48, Normal Altitude Natural Gas Only – GVSC-03	4	50894
	Orifice, #48, Normal Altitude Natural Gas Only – GVSC-04	6	50894
	Orifice, #48, Normal Altitude Natural Gas Only – GVSC-05	8	50894
	Orifice, #48, Normal Altitude Natural Gas Only – GVSC-06	10	50894
	Orifice, #56, Normal Altitude LP Gas Only – GVSC-03	4	50899
	Orifice, #56, Normal Altitude LP Gas Only – GVSC-04	6	50899
	Orifice, #56, Normal Altitude LP Gas Only – GVSC-05	8	50899
	Orifice, #56, Normal Altitude LP Gas Only – GVSC-06	10	50899
15	Gas Manifold – GVSC-03	–	50121
	Gas Manifold – GVSC-04	–	50122
	Gas Manifold – GVSC-05	–	50123
	Gas Manifold – GVSC-06	–	50124

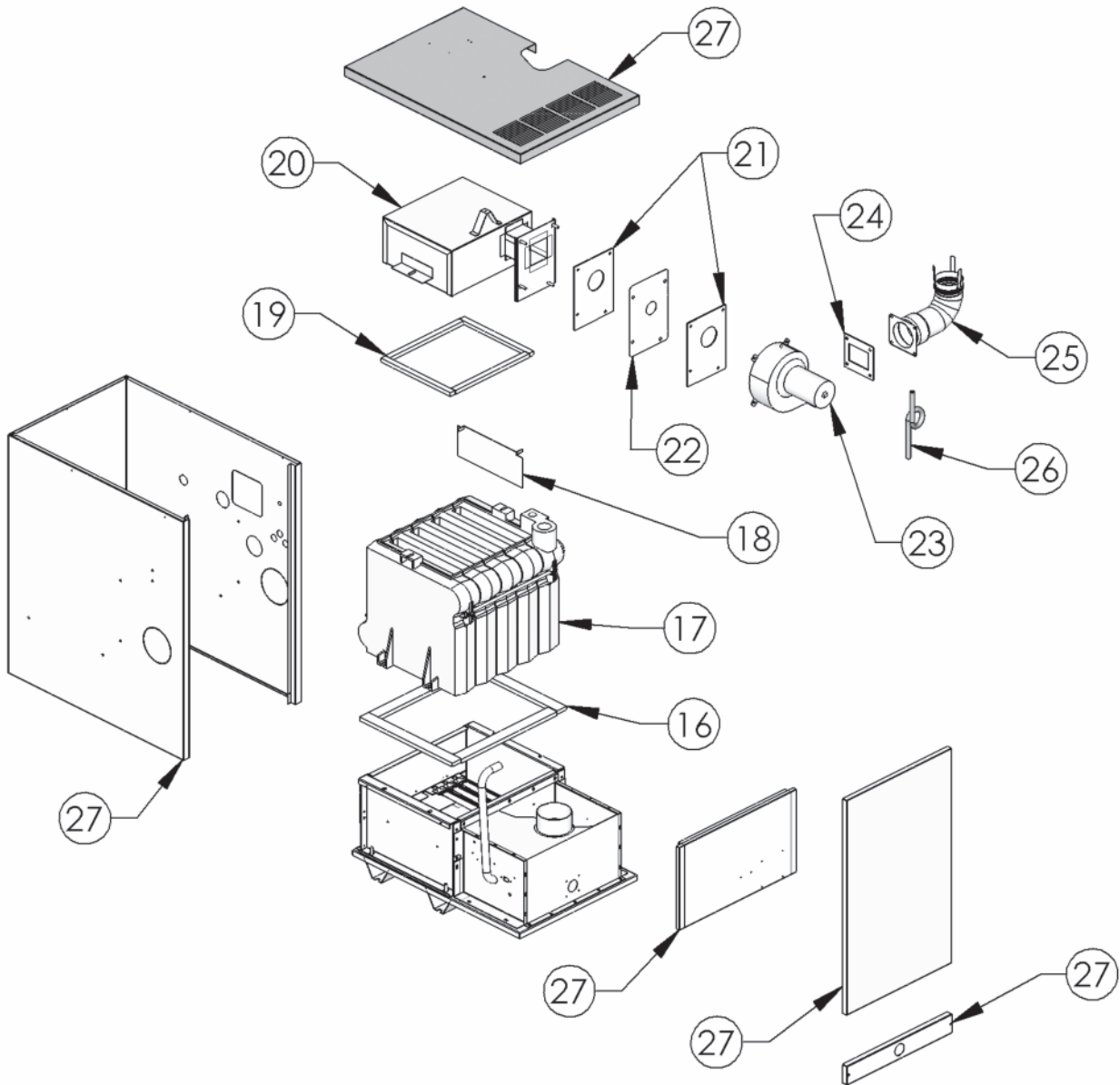

Figure 11.2

Table 11.2: Repair Parts (see note)

	Description	Quantity Required	Stock Code
16	Insulation Blanket, 1/2" x 1.50", Block to Base	–	50867
17	Block – GVSC-03	–	90419
	Block – GVSC-04	–	90420
	Block – GVSC-05	–	90421
	Block – GVSC-06	–	90422
18	Flue Baffle – GVSC-03	2	51584
	Flue Baffle – GVSC-04	3	51584
	Flue Baffle – GVSC-05	4	51584
	Flue Baffle – GVSC-06	5	51584
19	Insulation Blanket, 1/2" x .75", Flue Collector to Block	–	50866
20	Flue Collector – GVSC-03	–	50171
	Flue Collector – GVSC-04	–	50172
	Flue Collector – GVSC-05	–	50173
	Flue Collector – GVSC-06	–	50174
21	Gasket, Orifice Plate	2	50135
22	Orifice Plate, Normal Altitude Natural Gas Models Only – GVSC-03	–	PSC5002
	Orifice Plate, Normal Altitude Natural Gas Models Only – GVSC-04	–	PSC5002-1
	Orifice Plate, Normal Altitude Natural Gas Models Only – GVSC-05	–	PSC5002-2
	Orifice Plate, Normal Altitude Natural Gas Models Only – GVSC-06	–	PSC5002-3
	Orifice Plate, Normal Altitude LP Gas Models Only – GVSC-03	–	PSC5003
	Orifice Plate, Normal Altitude LP Gas Models Only – GVSC-04	–	PSC5003-1
	Orifice Plate, Normal Altitude LP Gas Models Only – GVSC-05	–	PSC5003-2
	Orifice Plate, Normal Altitude LP Gas Models Only – GVSC-06	–	PSC5003-3
23	Fan	–	50775
24	Fan Adapter	–	50200
25	Jacket – GVSC-03	–	90729
	Jacket – GVSC-04	–	90730
	Jacket – GVSC-05	–	90731
	Jacket – GVSC-06	–	90732
–	Gas Valve, VR8204A2001, Natural Gas Models Only	–	50583
–	Gas Valve, VR8204A2183, LP Gas Models Only	–	50584
–	Pressure Switch, Standard Altitude, .46" W.C. GVSC-03	–	50026
–	Pressure Switch, Standard Altitude .50" W.C. GVSC-04/05	–	50025
–	Pressure Switch, Standard Altitude .42" W.C. GVSC-06	–	50024
–	Safety Relief Valve, 30 PSI, Conbraco 10-408-05	–	50501
–	Safety Relief Valve, 50 PSI, Watts #350	–	99950
–	Temperature-Pressure Gauge	–	51774
–	Condensate Drain Elbow	–	51185
–	Outside Stainless Steel Vent Cap	–	50139
–	Wall Thimble (standard, up to 11-1/2" wall)	–	50137
–	Wall Thimble 20 (for a wall greater than 11-1/2" to 20")	–	90350
–	Inside Thimble Cap	–	50138
–	Inside Thimble Collar	–	50158
–	Screened Vent Termination	–	50130
–	Vent Clamp	–	51900
–	Limit Control, Beckett AquaSmart 7600B	–	50335
–	Immersion Well, Beckett 7600T	–	50341
–	Immersion Sensor, Beckett 7600P	–	50339
–	Limit Control, Hydrolevel HydroStat 3200	–	50334
–	Immersion Well, Hydrolevel	–	50723
–	Ignition Module, Honeywell S8610	–	50672
–	Pilot, Nat Gas, Q348A1002	–	50558
–	Pilot, LP Gas, Q348A1358	–	51814
–	Ignition Cable	–	50640
–	Relay, 24VAC Coil, DPST	–	50726
Blower Gaskets			
–	Orifice Plate Gaskets	2	50135
–	Fan Outlet Gasket	–	PSC5019

Note: Consult factory for control system repair parts for models with SmartValve ignition system. Furnish vendor part number of control that needs to be replaced and boiler serial number.

Part numbers may be subject to change without notice.

Smith
CAST IRON BOILERS

TEL. (413) 562-9631 • FAX (413) 562-3799