

# SIS SERIES SPLIT INVERTER AIR-TO-WATER HEAT PUMP



<b>SECTION 1: PREFACE</b> .....	2	<b>SECTION 5: CONTROL</b> .....	26
<b>SECTION 2: UNIT SPECIFICATIONS</b> .....	3	<b>SECTION 6: OPERATION</b> .....	28
<b>SECTION 3: INSTALLATION</b> .....	6	<b>SECTION 7: MAINTENANCE/TROUBLESHOOTING</b> ....	38
<b>SECTION 4: WIRING</b> .....	22		

## Section 1: Read Before Proceeding

### Hazard Definitions

The following terms are used throughout this manual to bring attention to the presence of potential hazards or to important information concerning the product.

**▲ DANGER** Indicates an imminently hazardous situation, which if not avoided, **WILL** result in death, serious injury or substantial property damage.

**▲ WARNING** Indicates an imminently hazardous situation, which if not avoided, **COULD** result in death, serious injury or substantial property damage.

**▲ CAUTION** Indicates an imminently hazardous situation, which if not avoided, **MAY** result in minor injury or property damage.

**NOTICE** Used to notify of special instructions on installation, operation or maintenance, which are important to equipment, but not related to personal injury hazards.

Failure to comply with these recommendations will void the warranty.

## Benefits and Features

- The SIS-060 Air-to-Water Heat Pump uses Inverter technology to precisely match the heating or cooling load. It contains an Enhanced Vapor Injection compressor for maximum performance in extreme heating conditions, and is installed in a split configuration, keeping all water and plumbing indoors, with only the compressor, fan and airside heat exchanger located outdoors.

### Advanced Controls

Unit function is managed by a parametric microprocessor allowing on site adjustment to tune the operation to match specific operating requirements.

### Easy Installation

The split configuration allows individual placement of the Indoor and Outdoor modules, up to 35' apart, and greatly simplifies plumbing installation.

### Quiet Operation

The insulated housing, advanced fan profile, and variable speed fan and compressor all combine to achieve a low noise level of 50dBa @ 3 meters (O.D. unit) and 38dBa @ 3 meters (I.D. unit).

### Efficient Energy Transfer

The SIS-060 is equipped with high efficiency, large surface area energy exchangers for both the Outdoor air to refrigerant heat transfer and the Indoor refrigerant to water energy transfer.

### Low Ambient Temperature Cooling Operation

The SIS-060 is capable of operating in cooling mode in ambient temperatures as low as 5°F.

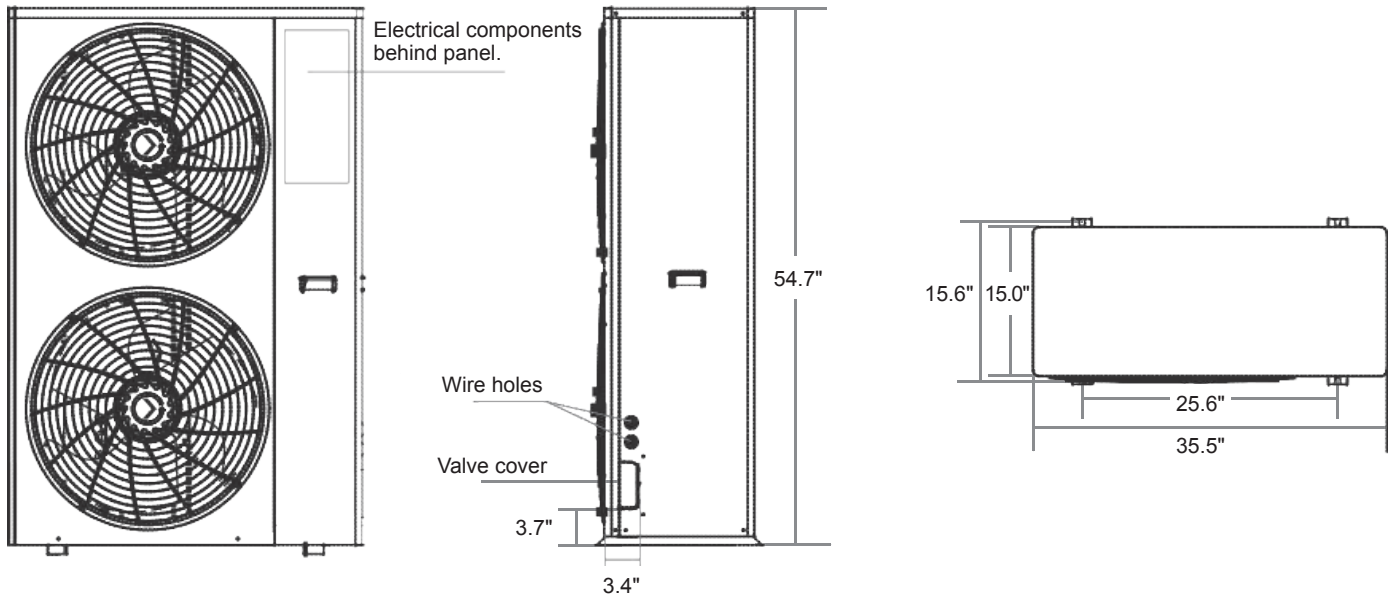
## Section 2: Unit Specifications

### 1. Initial Use

Prior to initial start-up all air must be removed from the hydronic loops, and power should be applied to the unit at least 8 hours prior to starting in heating or cooling. This will allow crankcase heater time to boil refrigerant out of compressor oil.

### Inverter Ultra-Low Temperature Air Source Heat Pump

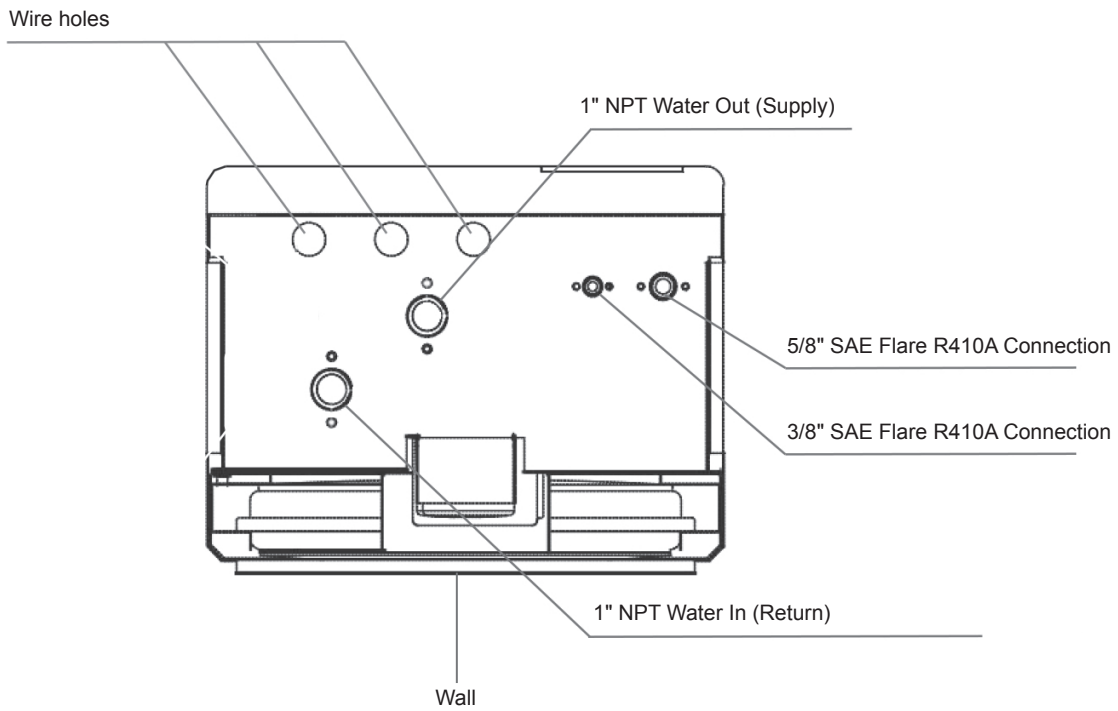
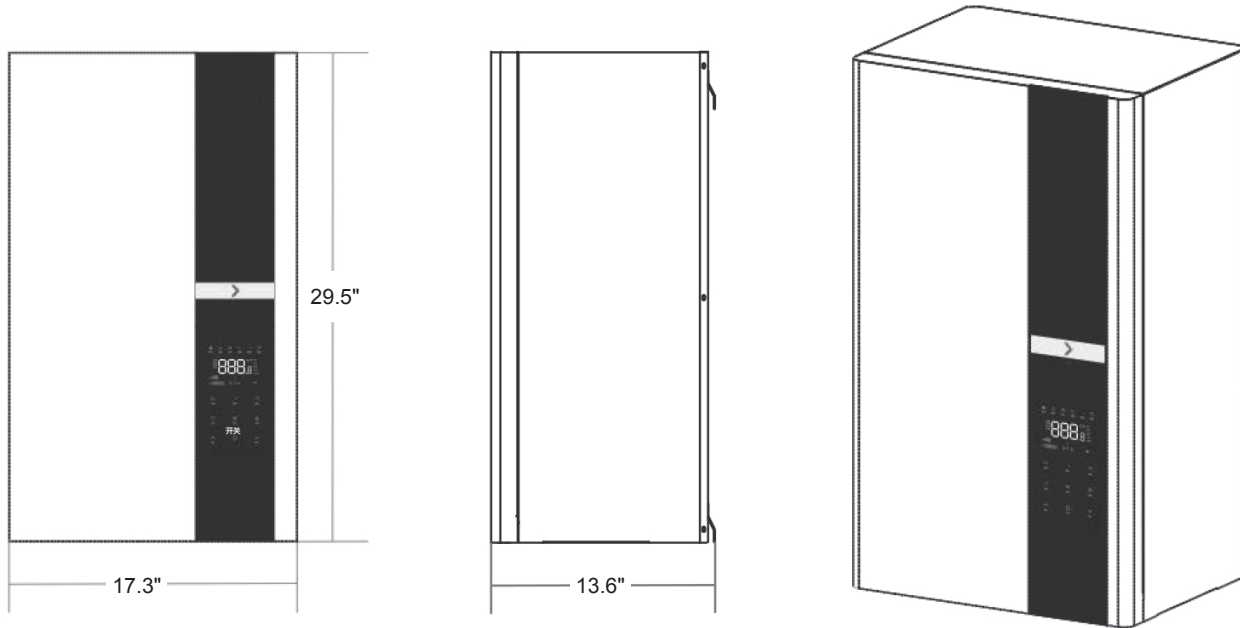
Figure 2.1 Outdoor Unit



## Unit Specifications

### Inverter Ultra-Low Temperature Air Source Heat Pump Water Heater

Figure 2.2 Indoor Unit





## Unit Specifications

		Outdoor	Indoor
Heating Capacity Range*	Btu/Hr	20,473-71,574	
Heating Efficiency*	COP	Up To 3.09	
Heating Capacity Range**	Btu/Hr	14,777-47,315	
Heating Efficiency**	COP	Up to 2.15	
Cooling Capacity Range***	Tons	2.5-5.2	
Cooling Efficiency***	EER	12.5	
Cooling Efficiency****	IPLV	17.14	
Water Temp Range	Deg F	41-130	
Compressor Frequency	Hz	30-90	
Power Supply	V/Ph/Hz	230/1/60	
MCA	Amps	40	15
MOPD	Amps	50	15
Refrigerant		R410A	
Refrigeration Connection		3/8 & 5/8 Flare	
Compressor		Panasonic Inverter-Drive EVI Scroll	
Water Connection	N.P.T.	N/A	N/A
Pressure drop (12 G.P.M)	P.S.I./ft W.C.	N/A	10.7/24.7
Fan Motor (Modulating)		EC Controlled	
Noise Level (@3meters)	dbA	50	38
Net Weight	Lbs	293	132
Shipping Weight	Lbs	337	158
Net Dimensions (L/W/H)	Inches	35x15x55	17x14x30
Shipping Dimension (L/W/H)	Inches	37x17x55	33x21x17
Operating Ambient Temp	Deg F	-20-110	

\*Water out- 120°F, Ambient- 47°F, G.P.M-12

\*\*Water out- 120°F, Ambient- 17°F, G.P.M-12

\*\*\*Water out- 45°F, Ambient (DB/WB)@- 95°F/86°F, G.P.M-12

\*\*\*\*IPLV is the recognized measurement of efficiency for Integrated Part Load Values in accordance with AHRI 550/590.

Ambient temp = 95°F. Delivered Water = 44°F (8.5GPM)

All data based on pure water

Heating						Cooling						
HZ	Water Temp	Ambient	Capacity	kW	COP	HZ	Water Temp	Ambient	Capacity	kW	EER	
90	100	-20	35,967	6.28	1.68	78	45	76	74,489	5.19	14.34	
		-4	42,109	6.46	1.91			89	66,912	5.89	11.36	
		17	50,609	6.75	2.20			95	63,125	6.38	9.90	
		47	76,023	7.26	3.07			101	58,449	6.79	8.60	
	120	-20	33,863	7.50	1.32		76	60,396	5.09	11.87		
		-4	39,645	7.70	1.51		89	54,253	5.77	9.40		
		17	47,648	8.05	1.73		95	51,182	6.25	8.19		
		47	71,574	8.66	2.42		101	47,391	6.66	7.12		
	130	-20	33,694	8.28	1.19		76	60,396	3.59	16.81		
		-4	39,368	8.73	1.32		89	54,253	4.07	13.32		
		17	47,315	9.12	1.52		95	51,182	4.41	11.60		
		47	71,074	9.81	2.12		101	47,391	4.70	10.09		
60	100	-20	15,535	2.45	1.86	60	45	76	50,310	3.51	14.34	
		-4	21,677	3.10	2.05			89	45,193	3.98	11.36	
		17	32,388	3.45	2.75			95	42,635	4.31	9.90	
		47	51,626	3.83	3.95			101	39,477	4.59	8.60	
	120	-20	14,627	2.92	1.47		30	45	76	35,231	1.95	18.05
		-4	20,409	3.70	1.62				89	31,648	2.21	14.30
		17	30,493	4.12	2.43				95	29,856	2.40	12.45
		47	48,605	4.57	3.12				101	27,645	2.55	10.83
	130	-20	14,553	3.23	1.32			76	27,380	1.73	15.82	
		-4	20,266	4.19	1.42			89	24,595	1.96	12.53	
		17	30,280	4.66	1.90			95	23,203	2.13	10.92	
		47	48,265	5.18	2.73			101	21,484	2.26	9.49	
30	100	-20							-20			
		-4	11,137	1.60	2.05				-4	10,486	1.90	1.62
		17	15,696	1.69	2.73				17	14,777	2.01	2.15
		47	21,746	1.63	3.92				47	20,473	1.94	3.09
	120	-20							-20			
		-4	10,486	1.90	1.62				-4	10,412	2.16	1.42
		17	14,777	2.01	2.15				17	14,674	2.28	1.89
		47	20,473	1.94	3.09				47	20,330	2.20	2.71
	130	-20							-20			
		-4	10,412	2.16	1.42				-4	10,412	2.16	1.42
		17	14,674	2.28	1.89				17	14,674	2.28	1.89
		47	20,330	2.20	2.71				47	20,330	2.20	2.71

## Section 3: Installation

### Choose the Right Heat Pump Unit

Perform appropriate load calculation to determine required heating or cooling load for the project. Refer to specifications in this manual to determine proper size heat pump.

### Installation Location

- The SISO module must be installed outdoors, in a location capable of supporting the full weight, plus any potential snow load. The outdoor unit must be secured to the support with sufficient hardware to withstand any potential wind or seismic conditions without shifting or tipping. Additionally the outdoor unit should be installed with enough clearance (see "E" dimension) to allow for condensate roll-off during the defrost cycle. This will prevent freezing under the unit during defrost.
- The outdoor module should be located away from sources of heat or moisture such as combustion vents, dryer vents, building exhausts etc.
- Proper clearances shown in Fig. 3.3 must be respected.

### Water Loop Connection

Please read below for water piping instructions

- The piping must be clean and free from dirt. Prior to insulating the pipe, it is suggested that a leak test be performed to ensure no water leaks are present.
- The system must be supplied with a pump sized to provide the minimum flow rate specified in the Glycol/Water System Design section of this manual. Pump selection must consider the pressure loss through the plumbing system and its components, plus the pressure loss through the Heat Pump's internal heat exchanger. The pump must be rated for the full range of heated or chilled water temperatures, as well as any anti-freeze or corrosion inhibitor additives.
- Install a wye strainer capable of system flow rate at anticipated level of contamination at the liquid input of the heat pump as shown in this manual to protect the internal components from damage or fouling due to contaminants or sediment.
- DO NOT use the heat pump for DIRECT heating of potable water. The heat exchanger and internal components are not suitable for this application.

**⚠ WARNING** Never expose the SIS Hydronic circuit to pressures in excess of 60 PSI. Loss of coolant, property damage or equipment damage may result.

The total system must be protected with a Pressure Relief Valve or valves sized to protect the system component with the lowest pressure rating. In no instance shall this exceed 60 PSI.

**⚠ CAUTION** If the indoor module is installed in a location where it may be exposed to freezing temperatures, it is the responsibility of the installing contractor to ensure that sufficient Propylene Glycol concentration is maintained in the hydronic circuit to provide freeze protection in all foreseeable conditions.

If the hydronic circuit is not charged with any anti-freeze solution, then the water must include a corrosion inhibitor suitable for hydronic systems, and installed according to the manufacturer's recommendations.

### Electrical Connections

Both the SISI indoor module and the SISO outdoor module must be connected to individual circuits, each sized and protected according to the Rating Labels affixed to the exterior of each module.

If the auxiliary heater function is employed, the electric elements must be powered by their own dedicated circuit, sized and protected according the auxiliary heater manufacturer's requirements.

Connect the RS485 communication wires using the two-conductor cable attached the supplied line set.

If the auxiliary heater or Domestic Hot Water functions are used, make electrical connections according to drawing labeled SISI Indoor Module Wiring.

All electrical connections must be made in accordance with the National Electric Code and all local codes and requirements.

## Water System

**Table 1 SIS Glycol Concentrations (10% Minimum, 35% Maximum)**

Propylene Glycol (concentration by volume)	10%	20%	25%	30%	35%
Min. temp of burst protection	22°F/-5.6°C	11°F/-11.7°C	-1°F/-18.3°C	-18°F/-27.8°C	-46°F/-43.3°C
Capacity Multiplier	0.99	0.98	0.97	0.96	0.94
Pressure Drop Multiplier (Cooling)	1.1	1.2	1.27	1.34	1.42
Pressure Drop Multiplier (Heating)	1.1	1.2	1.27	1.34	1.4
Minimum Expansion Volume/System Volume					
Heating and Cooling	1 gallon expansion per 15 gallons system volume				
Heating only, HP Only	1 gallon expansion per 20 gallons system volume				
Heating Only, with Boiler	1 gallon expansion per 15 gallons system volume				

**Table 2**
**Piping Pressure Losses\***

		Pressure Drop, Ft H <sub>2</sub> O/100ft*			
Pex Pipe	Flow Rate GPM	1"	1-1/4"	1-1/2"	2"
		6	5.5	1.7	-
	7	7.2	2.5	1.5	-
	8	9.1	3.4	1.8	-
	9	11.1	4.3	2.1	0.5
	10	13.4	5.2	2.4	0.6
	11	15.9	6.2	2.8	0.7
	12	18.5	7.2	3.2	0.9
	14	-	9.4	4.2	1.2
	16	-	11.8	5.4	1.6
Copper Pipe (Type L)	6	1.0	-	-	-
	7	1.4	0.5	-	-
	8	1.8	0.7	-	-
	9	2.2	0.8	0.3	-
	10	2.7	1.0	0.4	-
	11	3.2	1.2	0.5	0.1
	12	3.8	1.4	0.6	0.1
	14	-	1.8	0.8	0.2
	16	-	-	1.0	0.3

\*Remember to check the CV rating of your fittings and valves to make sure you're getting the required flow through the equipment.

## Water System Design

Each SIS Heat Pump has a recommended flow that should be maintained during all times of operation. For the SIS-060, the recommended flow is 12GPM at which the head loss is 25ft W.C., 11PSI or 73kPa. This head loss value is based upon pure water, see appendix for multipliers to correct for various concentrations of anti-freeze solution.

Note: these are the recommended flow values. Should the flow drop significantly below this value, the heat pump will shut down and show a flow error code on the display. This is not an indication of a fault in the heat pump, but rather points to insufficient pump or plumbing capacity, or air trapped within the system.

## System Volume and Expansion Volume

To ensure smooth temperature control and minimize cycling of refrigeration system, all installations must have total circulating volumes equal to or greater than 7.5 gallons per nominal ton of the unit performance at minimum capacity (The greater of either heating or cooling produced). In other words, in the case of a five ton heat pump with 3 to 1 turndown (0.33x rated capacity) the minimum total system volume is  $5 \times 0.33 \times 7.5 = 12.5$  gal. Multiple heat pump installations that are operating in a staged configuration follow the same rule, so that only a single heat pump tonnage needs to be considered. Additionally, the system requires an expansion volume (air) to compensate for the change in volume of the glycol mixture as it heats and cools, see Table 1 for expansion volume.

A typical multiple heat pump installation may actually have a volume far greater than the minimum required, and it is this entire volume that must be considered when sizing the expansion tank.

Note that the nominal expansion tank volume is not the same as the expansion volume. If the actual air volume is not published, consider it to be no more than half the nominal volume.

**As an example**, a five ton nominal heat pump operating down to 33% capacity, used for both heating and cooling, requires a minimum of 12.5 gallons of circulated system volume. A 13 gallon buffer tank is selected for best operation.

When the system installation is complete, the total volume including the heat pump, buffer tank, and all plumbing is 18 gallons. (Note: the expansion tank, no matter how large, is not considered circulated volume).

According to the chart above, the minimum **acceptance volume** of the expansion tank must be at least 18/15, or 1.2 gallons.

If the acceptance volume is not specified, assume it is no greater than 50% of the total tank volume.

Therefore in the case of this example, the system would require a minimum tank size of 2.4 gallons. As it is unlikely to find this specific size.

Always be sure to round up, so a tank of 3 gallons total volume, or larger, would be appropriate.

## Air Separator and Relief Valve

Locate at least one high efficiency air separator as shown in the piping to remove any air from the system. Install appropriately rated pressure relief valve common to the hydronic system.



## Glycol / Water Mixture

**⚠ WARNING** If unit is operating in a cooling capacity then the water system must contain a mixture of inhibited glycol and water with thermal protection sufficient for the coldest expected temperature for the installation. The inhibitor level can degrade over time, and may need to be adjusted periodically. The inhibitor is essential to prevent the glycol from accelerating corrosion of metal components in the system. The glycol and inhibitor levels must be checked regularly (no less than once annually).

**⚠ CAUTION** The minimum allowable concentration of glycol is 10% by volume in all installations.

**⚠ CAUTION** Automotive glycol is not suitable for use in the SIS system. Over time it may leave deposits which will degrade the performance and damage pumps or other devices in the system. Use only propylene glycol mixtures specifically labeled for boiler or HVAC use.

Obtain all components specified in the Typical System Diagram. Make sure all components and piping comply with applicable local codes.

**DO NOT** use galvanized pipe anywhere in the system. Galvanizing will react with the glycol and can cause glycol degradation and sludge in the system.

- Confirm charge of expansion tank is 12-15 PSIG (with no water or pressure in the system).
- Install the system piping. **DO NOT** connect the SpacePak unit to the system piping until the system has been cleaned as required below.

**The SIS must NOT be connected to the system during this process.**

1. Connect a hose from a fresh water supply to the system fill hose bib. Note the drain port can be used for this purpose. The hose bib purge/drain valve should be located low in the system and close to the SIS return connection.

2. Open the high point purge valve, (not shown in illustration, as it may be inside the air handler) while slowly filling the system. Close the valve when air is removed from the system and water begins to flow out of the valve.
3. Fill the system with fresh water and run water until the system has been thoroughly flushed clean.

Automatic Fill – When an automatic fill system is installed, the cooling fluid (Glycol/water) must be inspected at least every 3 months, or whenever a leak is detected to ensure the proper glycol concentration is maintained.

### **Pressure Test The System**

1. Add water to the system as needed to raise the pressure to 25 PSIG (verify that all system components are suitable for this pressure). Verify that the pressure remains constant for at least one hour. Locate and correct any leaks.
2. After successfully testing, drain the system and remove the fresh water hose.
3. After testing and draining the system, apply pipe insulation. Fill system with glycol/water mixture. Calculate the system volume.
4. See Table 1, for required glycol concentration for the minimum expected outside temperature.
5. Obtain the required volume inhibited glycol/water solution premixed or mix in a clean container. (The glycol must contain an inhibitor to prevent metal corrosion.)
6. Pump the glycol/water solution into the system, allowing air to escape through the purge valve(s).
7. After filling the system, sample the system fluid and verify glycol and inhibitor percentages, following instructions provided with the glycol.



## Preparations Before Installation

### Receiving Inspection

Upon receipt of the goods, the user shall inspect the unit carefully to confirm that no damage has occurred during the transport, that the screws are not loose, and that all spare parts have been received. If there is damage, please contact the manufacturer.

### Handling and Hoisting

For the outdoor unit (as shown in Figure 3.1), the weight is concentrated on the label side. When handling and arranging the slings, special attention should be paid to balance the unit's center of gravity to prevent falling over. Also note that outdoor unit should always remain in the upright position. Failure to comply will void warranty.

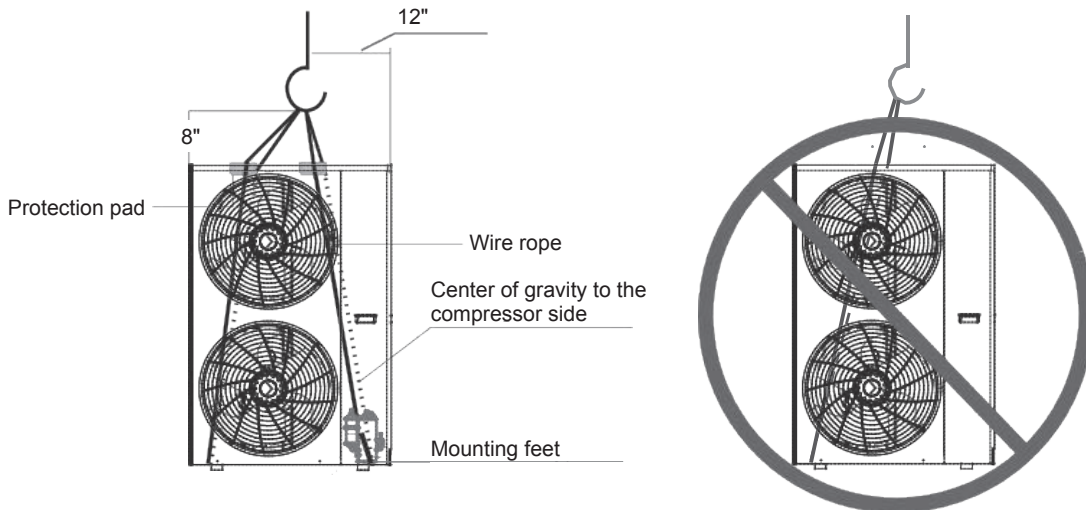
Do not touch the fins with bare hands, which may cut your fingers.

For ease of handling, the purchaser should use a fork lift truck or a cable crane. When using a cable crane, make sure the cable has sufficient load-bearing capacity which must be more than 3 times the weight of the unit. The cable should completely wind around the pallet, and a guard plate should be added to the surface of the unit body where the wire touches. During handling, the unit should be kept horizontal to avoid damage due to reckless operation.

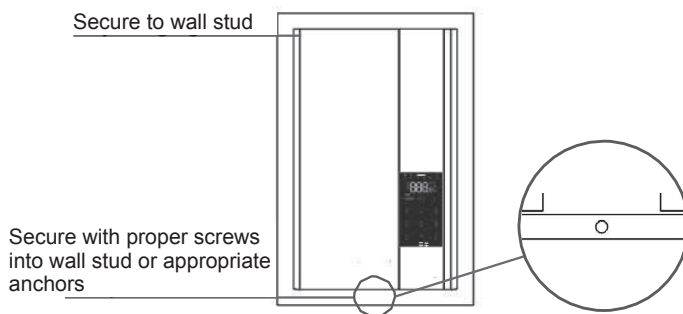
If the product is accompanied by a packaging tie, do not use the tie to lift or carry the product. The tie can easily break and cause accidents or danger.

The weight of the indoor unit (as shown in Fig. 3.2) is concentrated on the top of the body and fixed on the wooden board by means of a fixed beam. When handling, pay special attention to the direction to prevent falling over.

**Figure 3.1 Outdoor Unit**



**Figure 3.2 Indoor Unit**



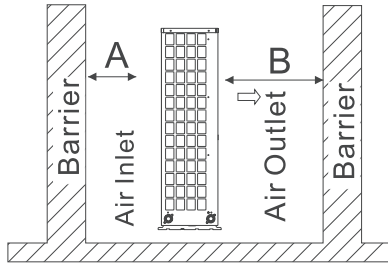
Before the unit is officially installed, remove the packaging, cut the packaging tape, and remove the bottom wood pallet. If using a cable, pass the cable to the designated location.

Dispose the plastic packaging bags properly and do not allow children to play.

## Clearances

When multiple outdoor units are installed, attention should be paid to their arrangement so as to ensure that the space around the outdoor units does not affect the installation of return air, air outlet, system piping, and other devices. The following arrangement is for reference:

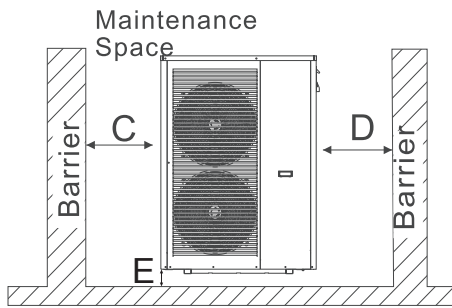
**Figure 3.3 Installation space for single outdoor unit (inches)**



**Attention**

Requirements  
 A > 20 inch ; B > 72 inch ;  
 C > 20 inch ; D > 40 inch ;  
 E = see note 1

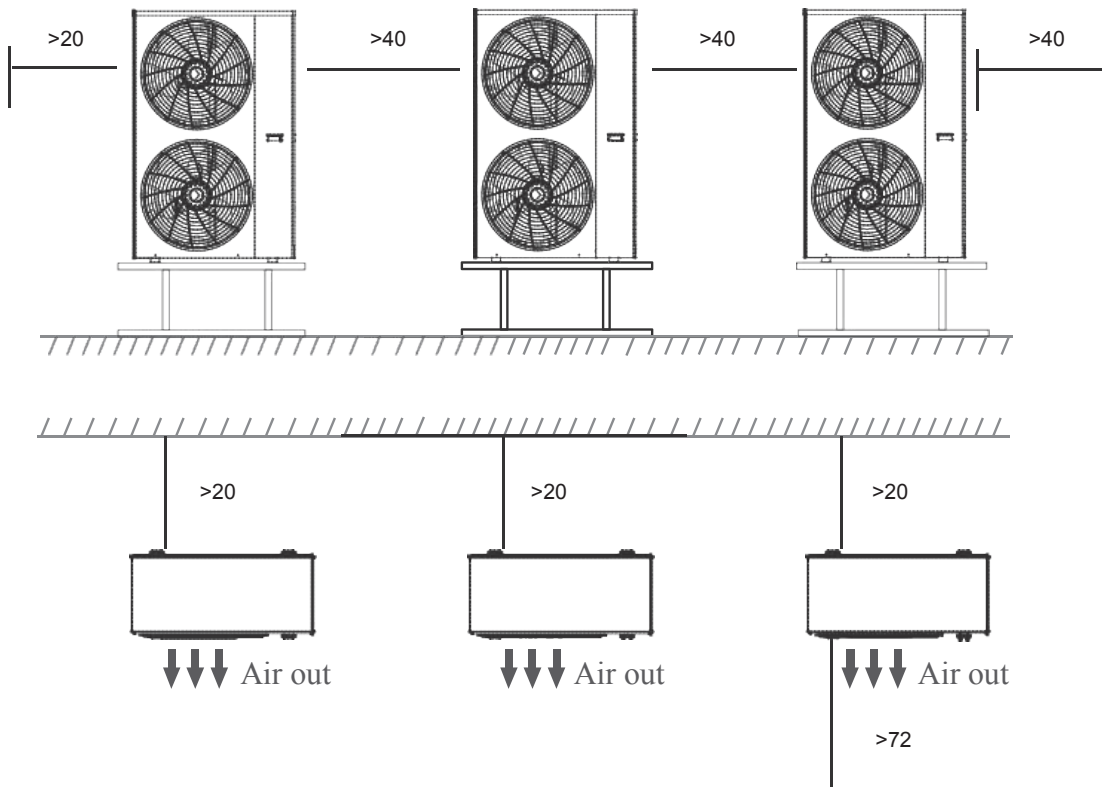
The minimum ventilation distance in diagram 1.



**Note:** The base of the unit should be located above winter snow level to allow proper drainage of condensate. The condensate should be provided a path to drain before refreezing in an area that could create an obstruction or hazardous conditions such as on a walkway.

The picture shows the location of horizontal air outlet unit.

**Figure 3.4 Installation space for multiple outdoor units (inches)**



**Do not block the air outlet of the outdoor unit.**

## Unit Installation

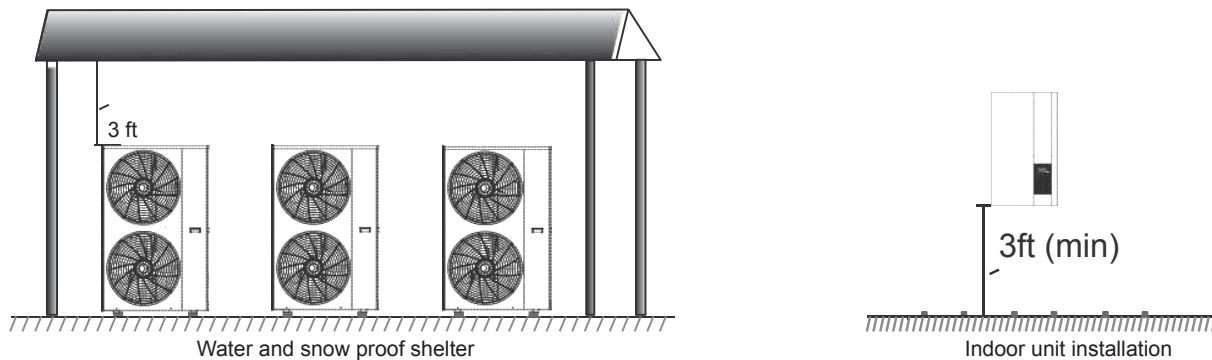
### Installation Position - Outdoor Unit

1. Unit should be set on a pad built strong enough to hold the weight of the unit. Pad should be pitched for condensate roll-off and de-frost roll off. Exhaust air and condensate should not affect neighbors.
2. The unit must not be installed in areas with corrosive gases, severe dust, salt spray, fumes, and flammable and explosive materials.
3. The installation site is well-ventilated. In the unit's exhaust and suction passages, it must be ensured that the air discharged by the unit or the air discharged by other units will not be sucked back into the unit. At the same time, there should be no obstruction in the exhaust and suction passage.
4. When the unit is installed, it is recommended to avoid installation to install it in a place vulnerable to strong winds or typhoon blows. Follow local codes for precautions against high winds and vibration such as hurricanes and earthquakes. Failure to do so may result in accidents such as dumping or falling of the unit. If conditions permit, auxiliary equipment such as rain, snow, and direct sunlight protection equipment can be installed.
5. The installation site should facilitate installation of piping and electrical connections. Please reserve enough space for maintenance of the unit; Please refer to the clearances section of this manual for proper clearances.
6. If the unit is mounted on the wall, it is necessary to take good drainage protection measures to prevent icing in winter due to low temperature, which may drop and cause injury.

### Installation Position - Indoor Unit

1. The unit installation site must be able to withstand the weight of the unit, and does not generate resonance with the unit and does not increase operation noise.
2. When installing use the base plate to aid in positioning and connection of the inlet and outlet hydronic piping along with the refrigerant line set.
3. The unit must not be installed in a location where it may be exposed to corrosive gas, serious dust, salt fog, fumes, and explosive materials.
4. The installation site should facilitate installation of piping and electrical connections.  
Please reserve enough space for maintenance of the unit;
5. To allow for easier piping connection to the system and the outdoor unit please mount the indoor unit at least 3ft off of the ground.
6. Position indoor unit with 3ft of maintenance clearance in front of unit.

Figure 3.5



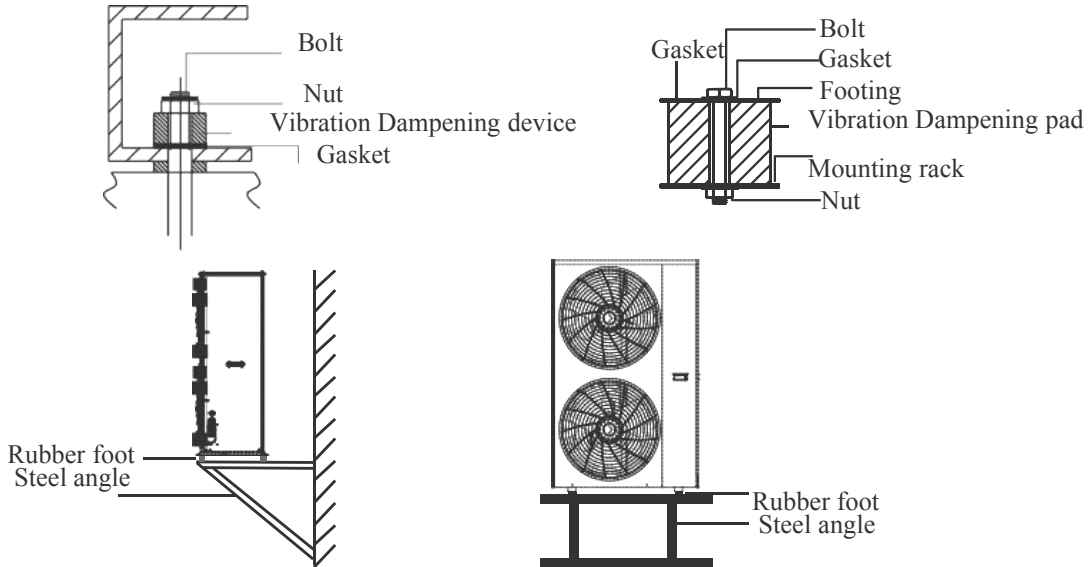
## Unit Installation

### Install Vibration Dampeners Device - Outdoor Unit

The unit is supplied with vibration dampeners, of which the installation method is as follows:

1. Ensure the flatness of concrete foundation and then place the unit on the vibration dampening pad;
2. Raise the unit to a height suitable for installing vibration dampeners;
3. Place the unit on the vibration dampeners with its bolt hole aligned with the hole on the base;
4. Install the gasket and nut properly and tighten the nut.

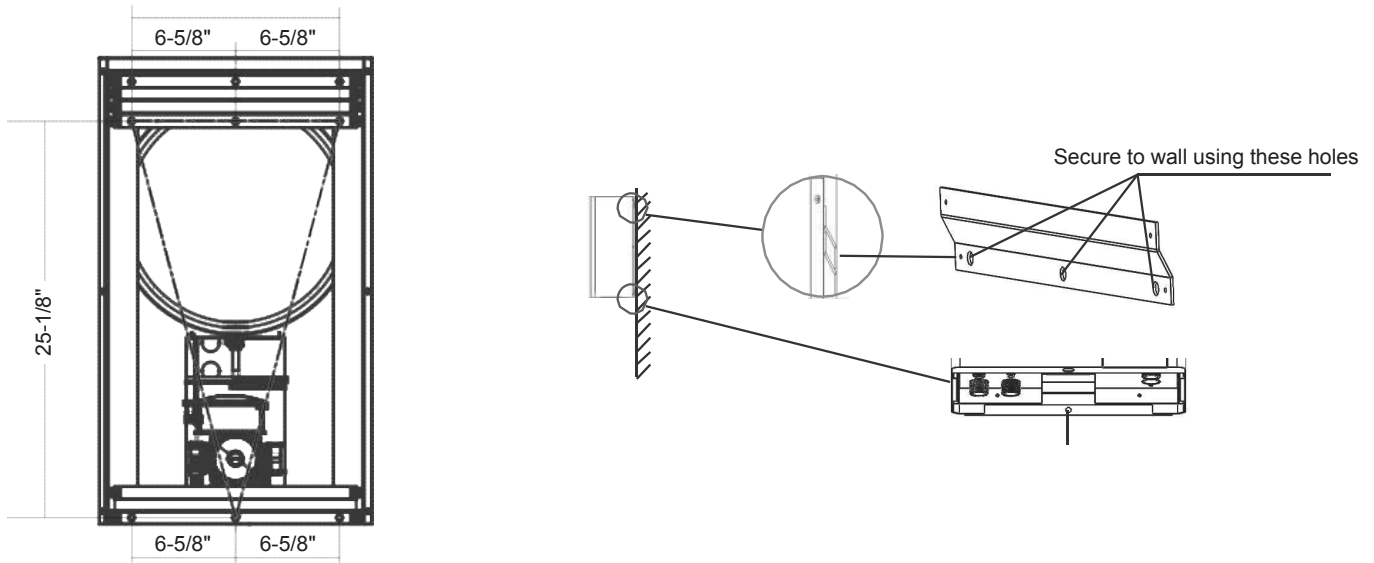
Figure 3.6



### Install - Indoor Unit

1. Select a wall that can withstand weight of the unit without increasing operation noise and vibration;
2. Secure the hanging beam of the accessory box horizontally on the wall;
3. Place the ribs of the unit on the hanging beam, and pay attention to the distance to the ground and ensure unit is properly centered on bracket.

Figure 3.7



## Unit Installation

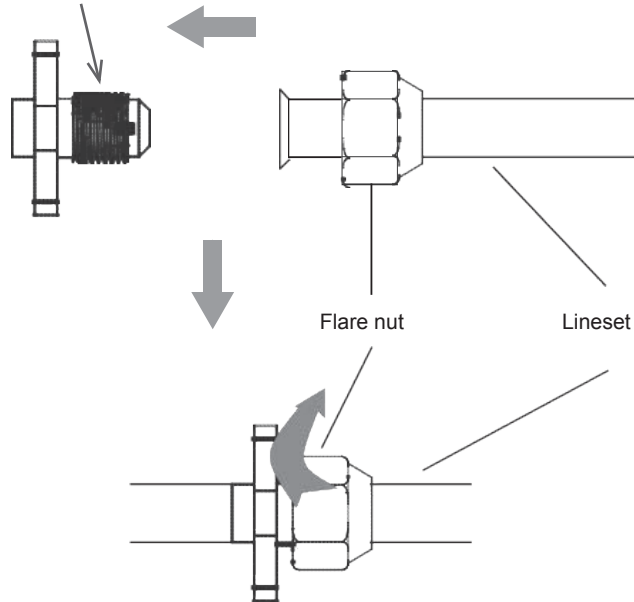
### Install Flare Connections

1. The tapered end of the connection pipe is aligned with the conical surface of corresponding valve connector;
2. Tighten the connection nut firmly with a wrench.
  - Connect line set to indoor unit before connecting to outdoor unit. Ensure proper routing of line set to avoid kinks or damage.
  - Make sure tightening torque of the nut is in accordance with the following table, otherwise connection may leak;
  - Line set is provided with proper insulation. During installation inspect the line set for any rips or tears. If any, please repair using insulation tape.

Line Set Diameter	Tightening Torque (ft-lbs)
3/8"	23-26
5/8"	44-48

### 3.8 Line Set Connection Diagram

Apply proper POE oil on flare surfaces to ensure secure connection. Be sure to use proper wrenches to tighten all flare connections.

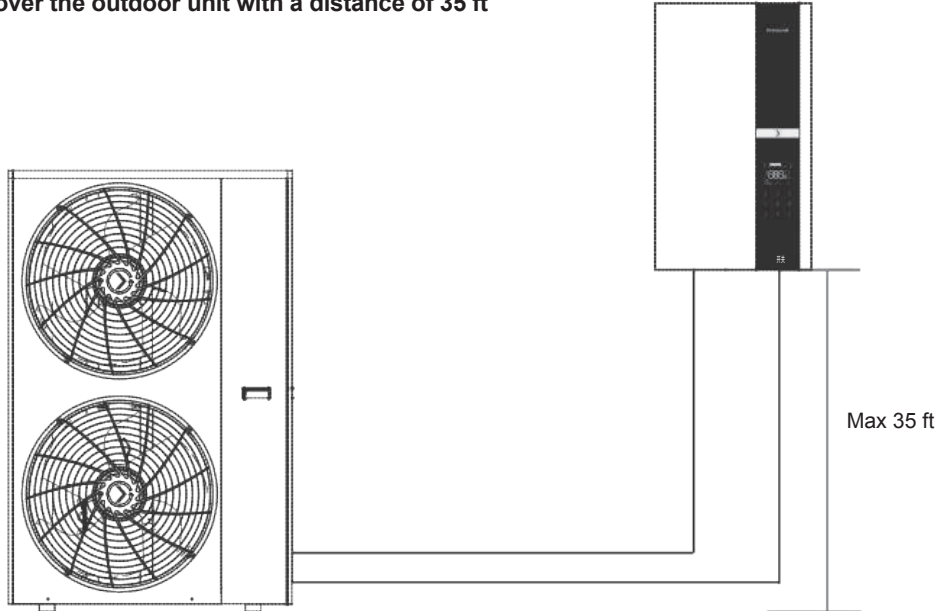


## Unit Installation

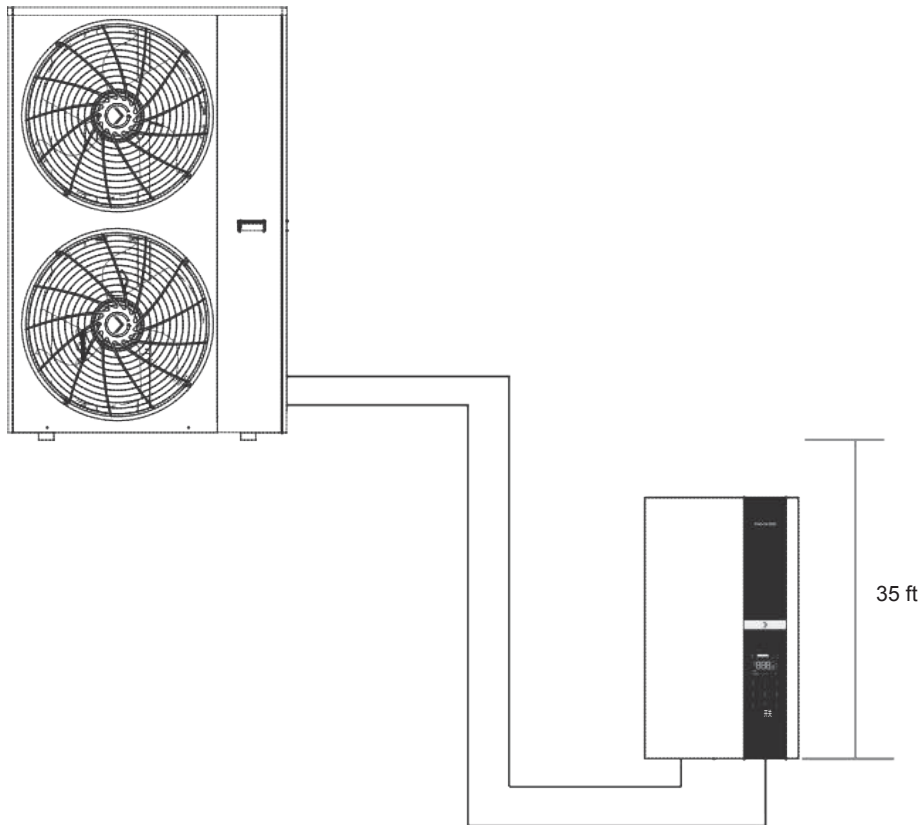
### Line Set Requirements

The maximum line set length is 35ft. This can be any combination of vertical or horizontal run, with the outdoor unit either above or below the indoor unit, but cannot be exceeded.

**Figure 3.9 Indoor unit over the outdoor unit with a distance of 35 ft**



**Figure 3.10 Indoor unit under the outdoor unit with a distance of 35 ft**



## Refrigerant Charging

This section provides details on installation and charging of the refrigeration line set with the unit.

Field refrigerant piping consists of liquid and suction lines from the outdoor unit to the indoor unit coil.

If refrigerant lines are routed through a wall, seal and isolate the opening so vibration is not transmitted to the building. Pay close attention to line set isolation during installation of any HVAC system. When properly isolated from building structures (walls, ceilings, floors), the refrigerant lines will not create unnecessary vibration and subsequent sounds.

**IMPORTANT** Mineral oils are not compatible with HFC-410A. If oil must be added, it must be a Polyol ester oil.

**IMPORTANT** Each split system (indoor and outdoor) units come pre-charged with refrigerant up to 16ft. For installations more than 16ft (max 35) please refer to table for the appropriate oz needed. The split system should ONLY be charged based off of the charging table and the "weigh-in method."

### Charging Table

R410a Charging Table	
Feet	Add (oz)
<16	0
17	0.3
18	0.9
19	1.4
20	1.9
21	2.5
22	3
23	3.5
24	4.1
25	4.6
26	5.2
27	5.7
28	6.2
29	6.8
30	7.3
31	7.9
32	8.4
33	8.9
34	9.5
35	10

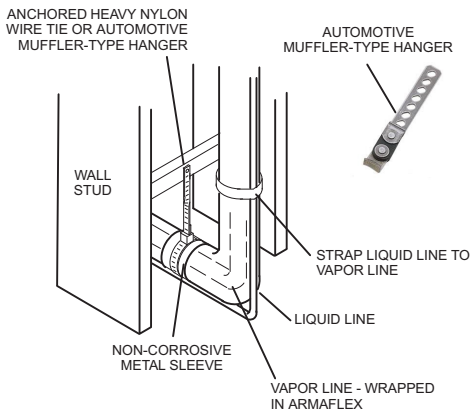
# LINE SET

**IMPORTANT** — Refrigerant lines must not contact structure.

### INSTALLATION

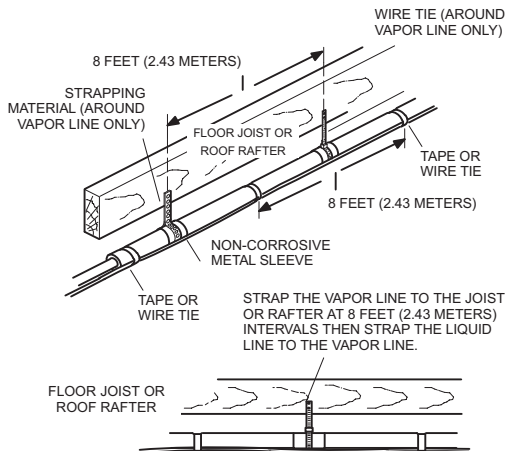
**Line Set Isolation** — The following illustrations are examples of proper refrigerant line set isolation:

#### REFRIGERANT LINE SET — TRANSITION FROM VERTICAL TO HORIZONTAL



#### REFRIGERANT LINE SET — INSTALLING HORIZONTAL RUNS

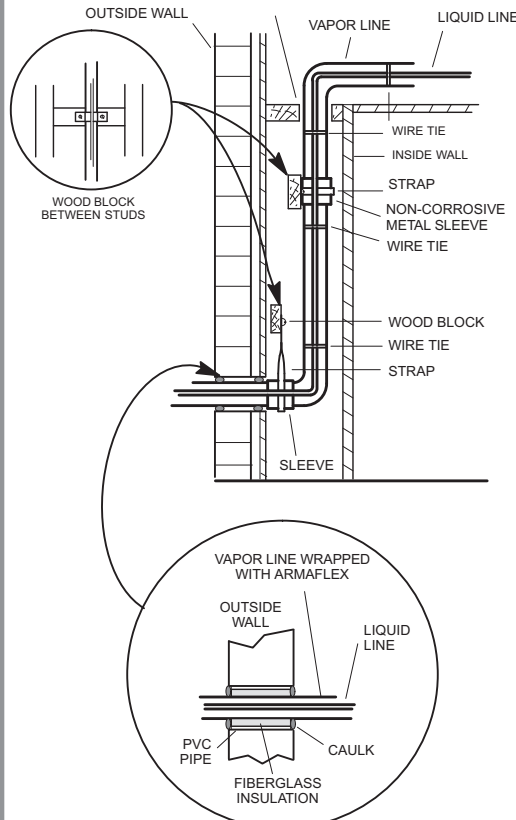
To hang line set from joist or rafter, use either metal strapping material or anchored heavy nylon wire ties.



#### REFRIGERANT LINE SET — INSTALLING VERTICAL RUNS (NEW CONSTRUCTION SHOWN)

**NOTE** — Insulate liquid line when it is routed through areas where the surrounding ambient temperature could become higher than the temperature of the liquid line or when pressure drop is equal to or greater than 20 psig.

**IMPORTANT** — Refrigerant lines must not contact wall



**NOTE** — Similar installation practices should be used if line set is to be installed on exterior of outside wall.

**IMPORTANT** Polyol ester (POE) oils used with HFC-410A refrigerant absorb moisture very quickly. It is very important that the refrigerant system be kept closed as much as possible. DO NOT remove line set caps or service valve stub caps until you are ready to make connections.

**WARNING** When using a high pressure gas such as dry nitrogen to pressurize a refrigeration or air conditioning system, use a regulator that can control the pressure down to 1 or 2 psig (6.9 to 13.8 kPa).

**WARNING** Fire, Explosion and Personal Safety Hazard. Failure to follow this warning could result in damage, personal injury or death. Never use oxygen to pressurize or purge refrigeration lines. Oxygen, when exposed to a spark or open flame, can cause fire and/or an explosion, that could result in property damage, personal injury or death.



**▲IMPORTANT** The Environmental Protection Agency (EPA) prohibits the intentional venting of HFC refrigerants during maintenance, service, repair and disposal of appliance. Approved methods of recovery, recycling or reclaiming must be followed.

### Leak Test Line Set and Indoor Coil

**▲IMPORTANT** Leak detector must be capable of sensing HFC refrigerant.

After completing the leak testing the line set and indoor coil, proceed to *Evacuating Line Set and Indoor Coil*.

**▲WARNING** When using a high pressure gas such as dry nitrogen to pressurize a refrigeration or air conditioning system, use a regulator that can control the pressure down to 1 or 2 psig (6.9 to 13.8 kPa).

**▲WARNING** Refrigerant can be harmful if it is inhaled. Refrigerant must be used and recovered responsibly. Failure to follow this warning may result in personal injury or death.

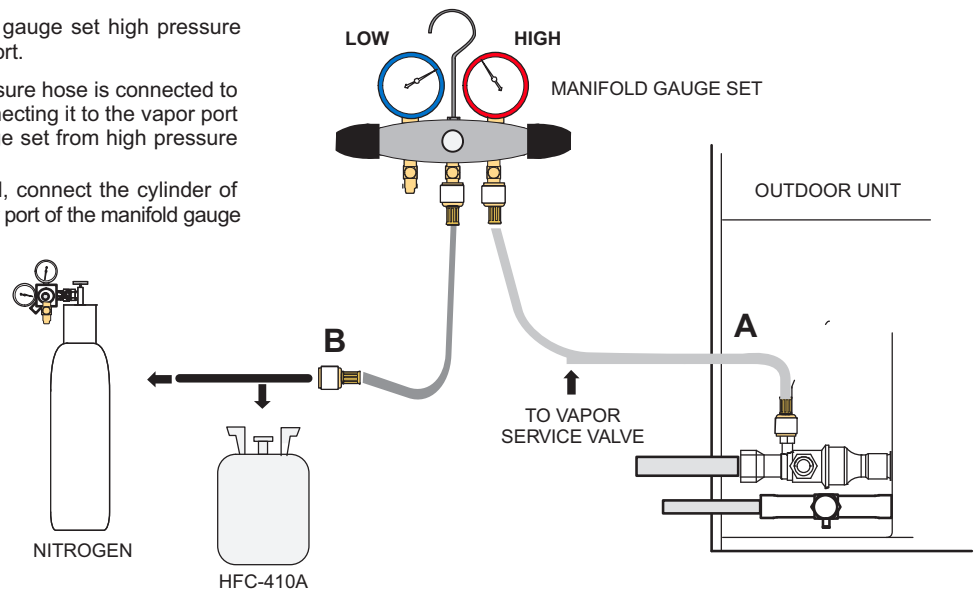
## 1 CONNECT GAUGE SET

- A Connect an HFC-410A manifold gauge set high pressure hose to the vapor valve service port.

**NOTE** — Normally, the high pressure hose is connected to the liquid line port. However, connecting it to the vapor port better protects the manifold gauge set from high pressure damage.

- B With both manifold valves closed, connect the cylinder of HFC-410A refrigerant to the center port of the manifold gauge set.

**NOTE** — Later in the procedure, the HFC-410A container will be replaced by the nitrogen container.



## 2 TEST FOR LEAKS

After the line set has been connected to the indoor and outdoor units, check the line set connections and indoor unit for leaks. Use the following procedure to test for leaks:

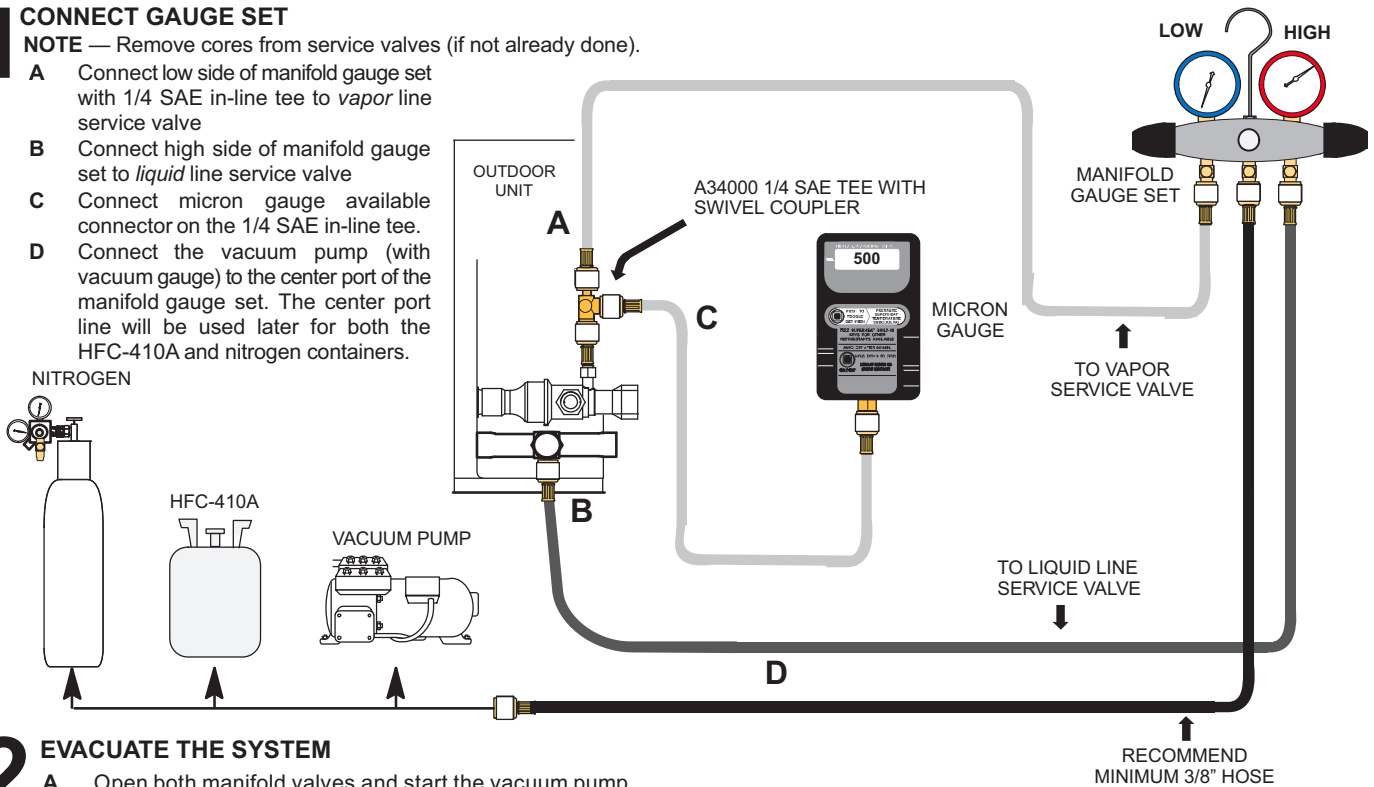
- A With both manifold valves closed, connect the cylinder of HFC-410A refrigerant to the center port of the manifold gauge set. Open the valve on the HFC-410A cylinder (vapor only).
- B Open the high pressure side of the manifold to allow HFC-410A into the line set and indoor unit. Weigh in a trace amount of HFC-410A. [A trace amount is a maximum of two ounces (57 g) refrigerant or three pounds (31 kPa) pressure]. Close the valve on the HFC-410A cylinder and the valve on the high pressure side of the manifold gauge set. Disconnect the HFC-410A cylinder.
- C Connect a cylinder of dry nitrogen with a pressure regulating valve to the center port of the manifold gauge set.
- D Adjust dry nitrogen pressure to 150 psig (1034 kPa). Open the valve on the high side of the manifold gauge set in order to pressurize the line set and the indoor unit.
- E After a few minutes, open one of the service valve ports and verify that the refrigerant added to the system earlier is measurable with a leak detector.
- F After leak testing disconnect gauges from service ports.

**Evacuating Line Set and Indoor Coil**

**1 CONNECT GAUGE SET**

**NOTE** — Remove cores from service valves (if not already done).

- A** Connect low side of manifold gauge set with 1/4 SAE in-line tee to vapor line service valve
- B** Connect high side of manifold gauge set to liquid line service valve
- C** Connect micron gauge available connector on the 1/4 SAE in-line tee.
- D** Connect the vacuum pump (with vacuum gauge) to the center port of the manifold gauge set. The center port line will be used later for both the HFC-410A and nitrogen containers.

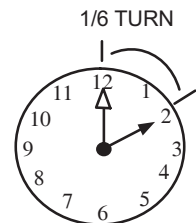


**2 EVACUATE THE SYSTEM**

- A** Open both manifold valves and start the vacuum pump.
- B** Evacuate the line set and indoor unit to an **absolute pressure** of 23,000 microns (29.01 inches of mercury).
 

**NOTE** — During the early stages of evacuation, it is desirable to close the manifold gauge valve at least once. A rapid rise in pressure indicates a relatively large leak. If this occurs, **repeat the leak testing procedure**.

**NOTE** — The term **absolute pressure** means the total actual pressure within a given volume or system, above the absolute zero of pressure. Absolute pressure in a vacuum is equal to atmospheric pressure minus vacuum pressure.
- C** When the absolute pressure reaches 23,000 microns (29.01 inches of mercury), perform the following:
  - Close manifold gauge valves
  - Close valve on vacuum pump
  - Turn off vacuum pump
  - Disconnect manifold gauge center port hose from vacuum pump
  - Attach manifold center port hose to a dry nitrogen cylinder with pressure regulator set to 150 psig (1034 kPa) and purge the hose.
  - Open manifold gauge valves to break the vacuum in the line set and indoor unit.
  - Close manifold gauge valves.
- D** Shut off the dry nitrogen cylinder and remove the manifold gauge hose from the cylinder. Open the manifold gauge valves to release the dry nitrogen from the line set and indoor unit.
- E** Reconnect the manifold gauge to the vacuum pump, turn the pump on, and continue to evacuate the line set and indoor unit until the absolute pressure does not rise above 500 microns (29.9 inches of mercury) within a 20-minute period after shutting off the vacuum pump and closing the manifold gauge valves.
- F** When the absolute pressure requirement above has been met, disconnect the manifold hose from the vacuum pump and connect it to an upright cylinder of HFC-410A refrigerant. Open the manifold gauge valve 1 to 2 psig in order to release the vacuum in the line set and indoor unit.
- G** Perform the following:
  - Close manifold gauge valves.
  - Shut off HFC-410A cylinder.
  - Reinstall service valve cores by removing manifold hose from service valve. Quickly install cores with core tool while maintaining a positive system pressure.
  - Replace stem caps and secure finger tight, then tighten an additional one-sixth (1/6) of a turn as illustrated.



**⚠️WARNING** Danger of Equipment Damage. Avoid deep vacuum operation. Do not use compressors to evacuate a system. Extremely low vacuums can cause internal arcing and compressor failure. Damage caused by deep vacuum operation will void warranty.

Evacuating the system of non-condensables is critical for proper operation of the unit. Non-condensables are defined as any gas that will not condense under temperatures and pressures present during operation of an air conditioning system. Non-condensables and water suction combine with refrigerant to produce substances that corrode copper piping and compressor parts.

**⚠️IMPORTANT** Use a thermocouple or thermistor electronic vacuum gauge that is calibrated in microns. Use an instrument capable of accurately measuring down to 50 microns.

**⚠️WARNING** Electric Shock Hazard. Can cause injury or death. Unit must be grounded in accordance with national and local codes. Line voltage is present at all components when unit is not in operation on units with single-pole contactors. Disconnect all remote electric power supplies before opening access panel. Unit may have multiple power supplies.

## Unit Installation

When the outdoor unit is delivered, the drain nozzle is placed on the body and the drain rubber plug is placed in the attachment.

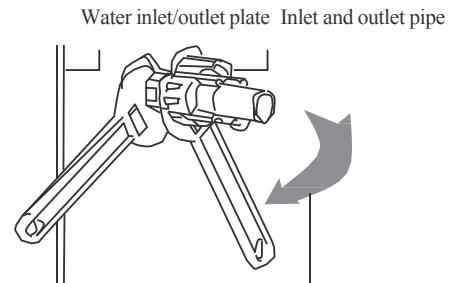
It is important to note that during *defrost* cycle, the unit will produce significant condensation. The installation of the outdoor unit should be mounted high enough to let condensate drain and not to freeze during winter months. Refer to unit clearance section of this manual for proper heights.

### Hydronic Piping Installation

*(Refer to piping diagram located in this document for individual component list and suggest piping arrangement)*

1. Prior to startup, ensure all piping is clean and free of debris. Be sure to clean piping separately (valve off) from units in order to not introduce any contaminants to the system.
2. When tightening pipes please use two wrenches as shown in the diagram to properly secure without causing damage to heat exchanger.

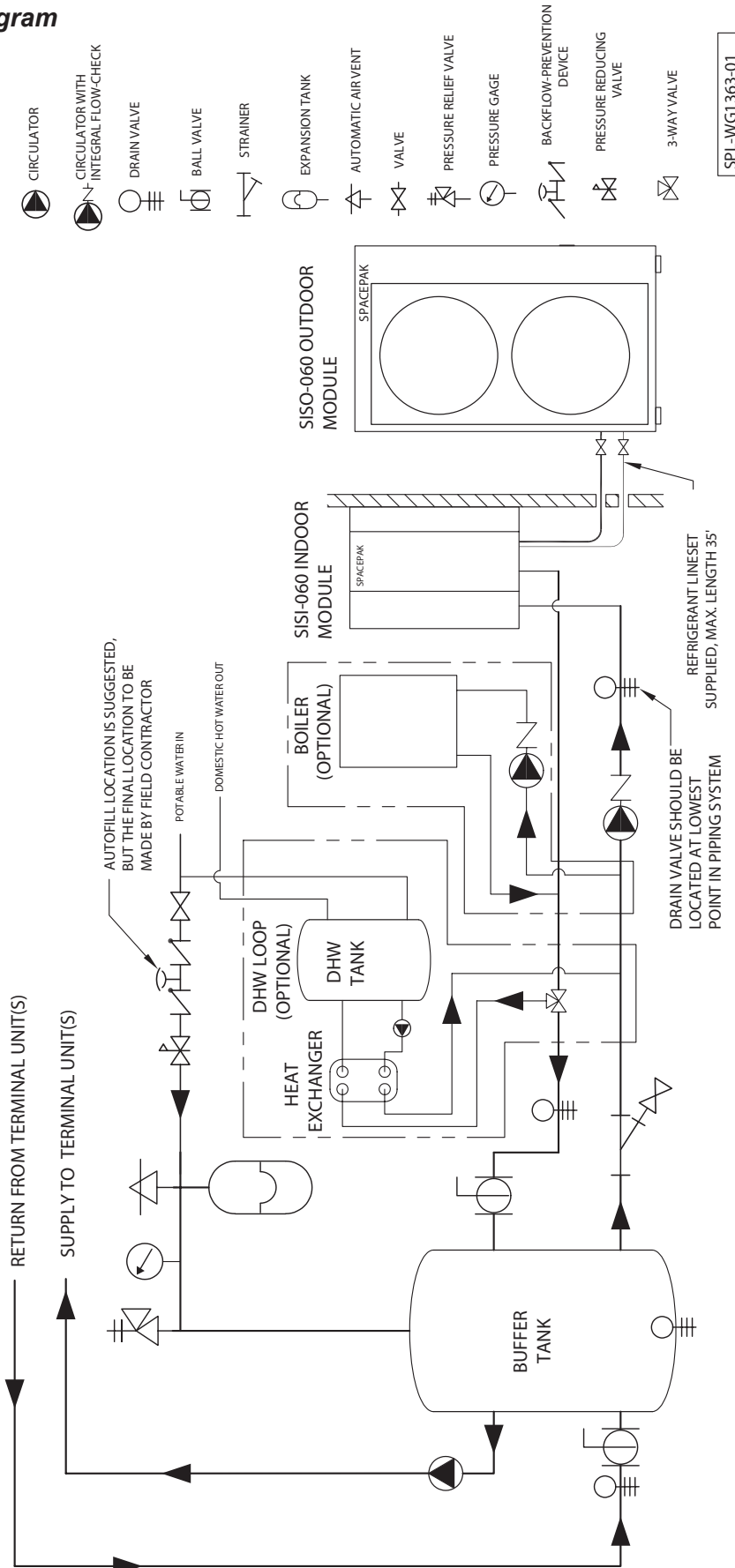
**Customer shall inspect the water system on a regular basis for leaks and any contaminants.**



# Installation

## Typical System Diagram

Figure 3.11



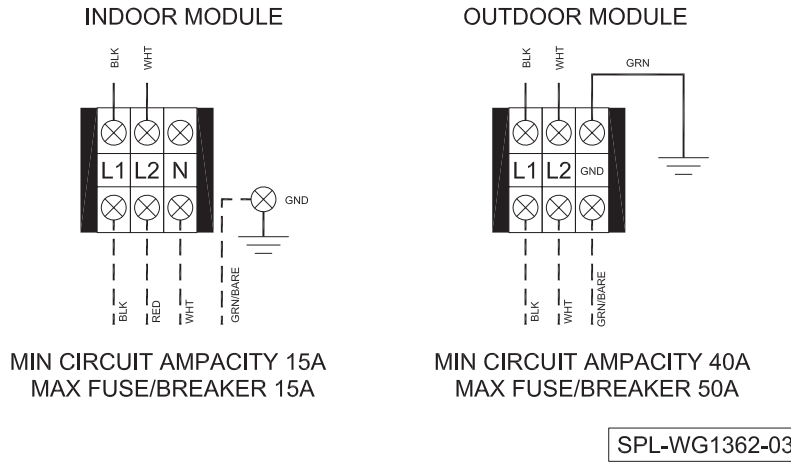
## Electrical Installation

### Attention

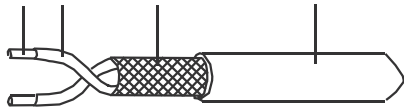
All electrical installation and wiring must be in accordance with the National Electrical Code ANSI/NFPA No. 70-latest edition and any additional state or local code requirements. Failure to comply will void the warranty and potentially cause serious injury and/or damage to the installed products. Please follow wiring diagrams and associated wiring connection diagrams.

**Figure 3.12 Power Supply Connection Diagram**

Indoor unit and outdoor units must be powered by separate circuits, each protected by fuses or circuit breakers not exceeding the values posted on the data plate.



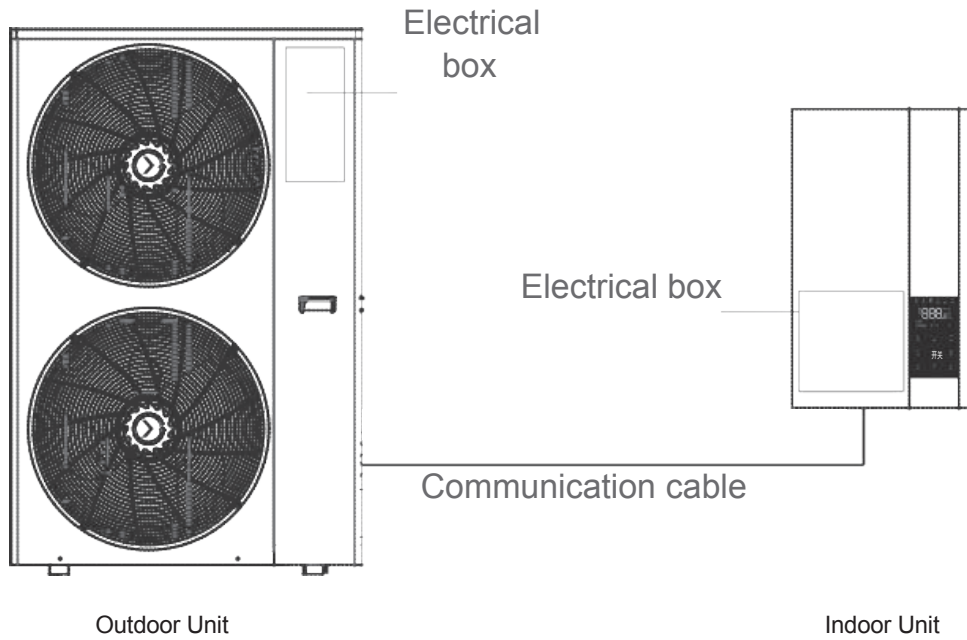
**Figure 3.13 RS485 Communication Cable (attached to lineset provided with unit)**



## Electrical Installation

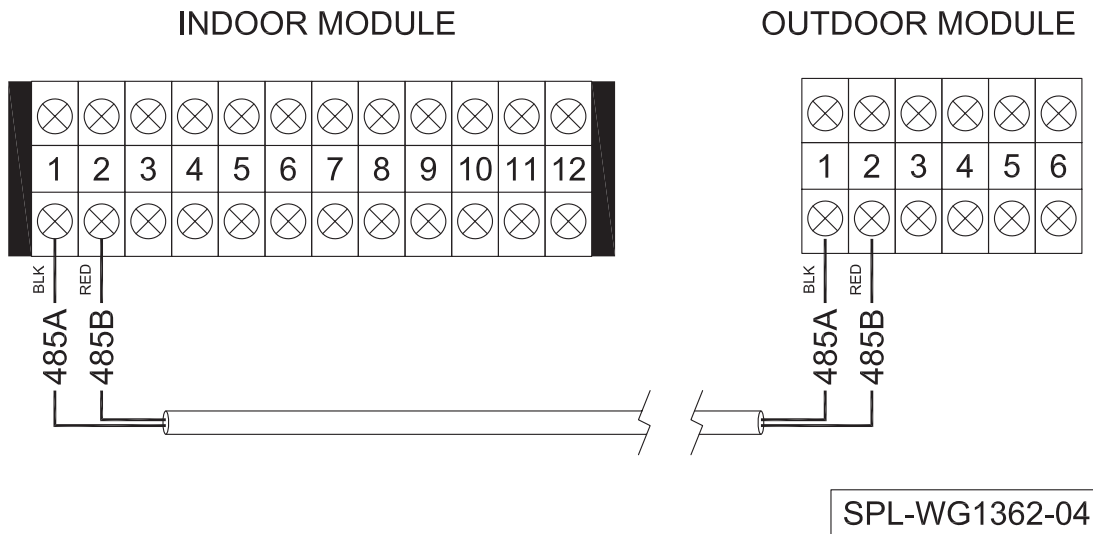
The RS485 Communication Cable shall be separated from any line voltage conductors. It shall be installed to protect from weather or fraying during installation.

**Figure 3.14**



Refer to wiring diagram for internal connections.

**Figure 3.15**



The electrical loads given in the Specification Table, allow for a pump load of no more than 5 amps at 110 VAC (2.5 amps at 230 VAC). If the pump load exceeds this, provide a separate power source to the pump. DO NOT feed power to the pump from the SpacePak air handler panel.

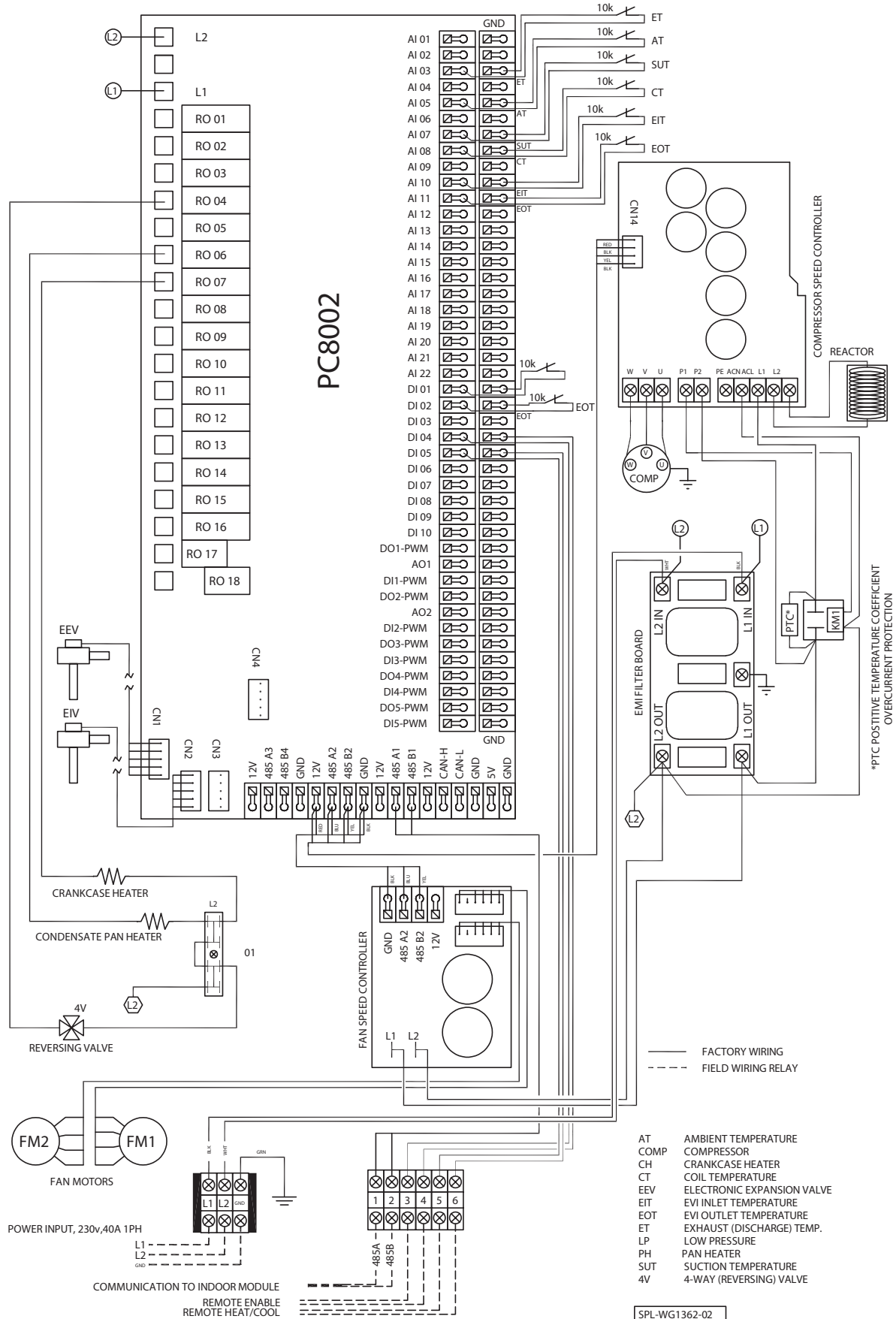
### SIS Control Wiring Connection

The SpacePak SIS requires a dry contact (relay) signal to enable and select between heating and cooling modes. They will not operate on the 24V signals from typical thermostats or air handlers. Connecting 24V to either of these points will result in significant component damage.

- Connect multiple zone system to heat pump using SpacePak SSIC Control Module and instructions included with it. Refer to manual supplied with SSIC Control Module for connection and operational details.
- See wiring diagram for heat pump electrical diagram.

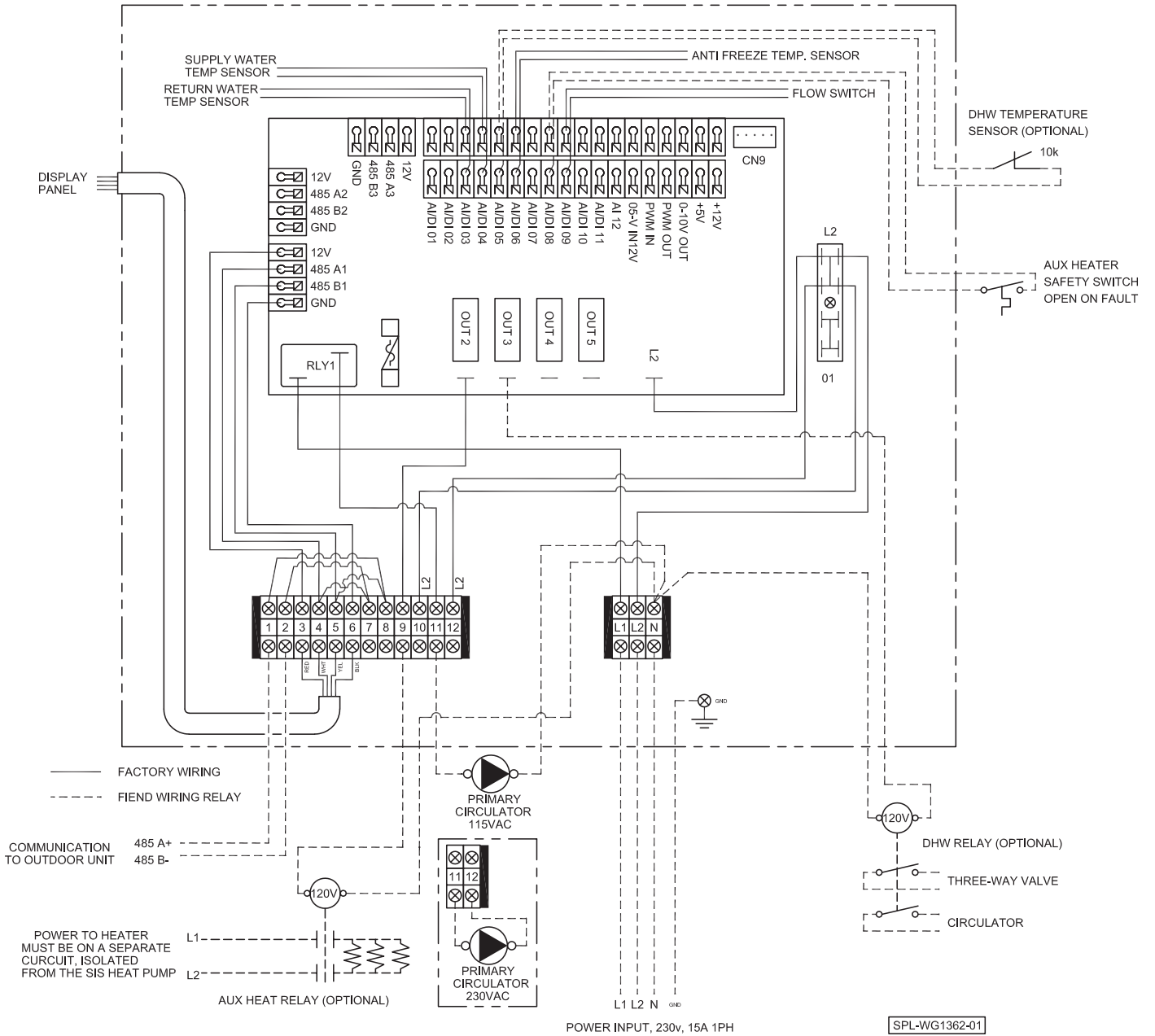
**Section 4: Wiring**

Figure 4.1 SIS Outdoor Unit



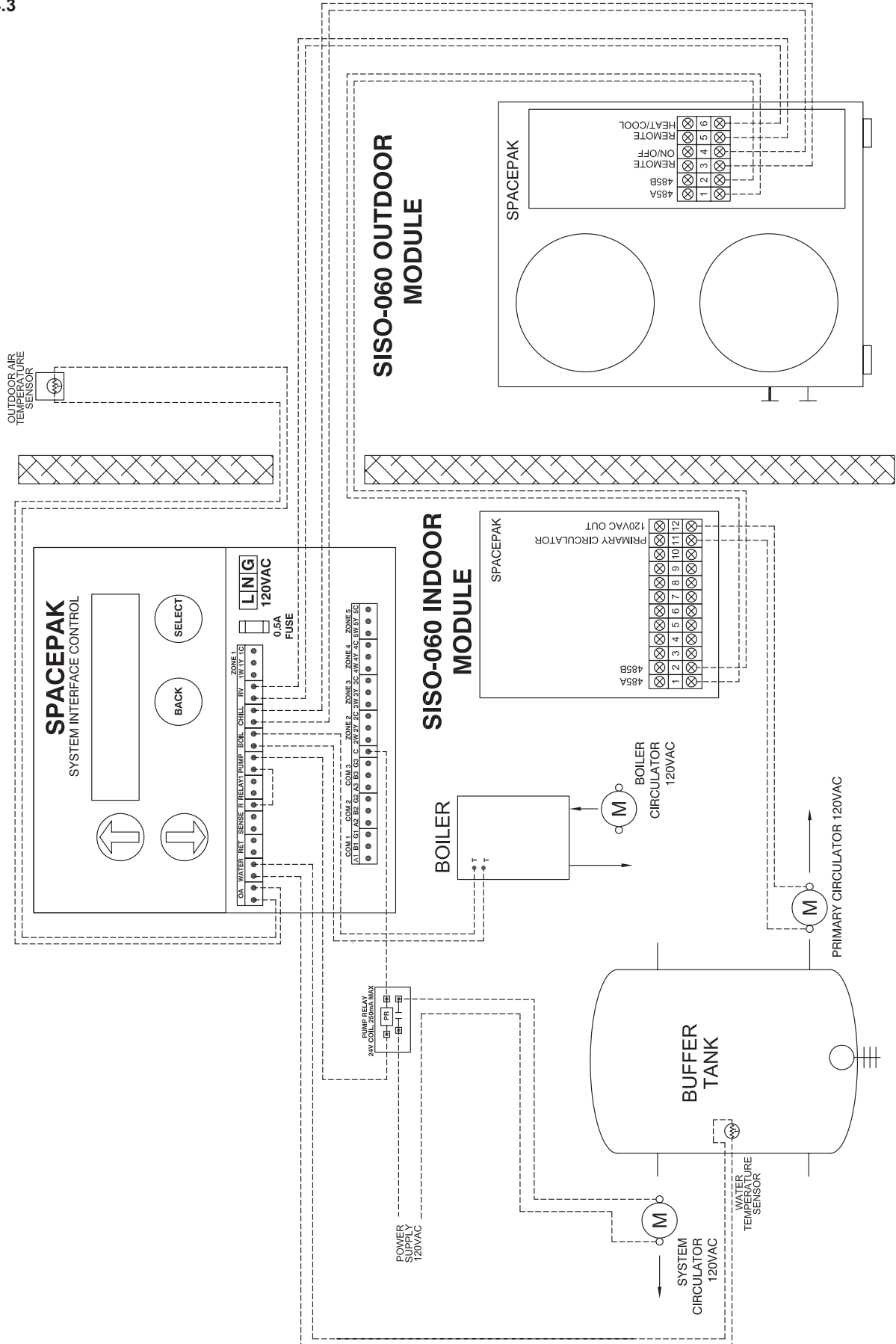


**Wiring**  
Figure 4.2



# Wiring with SSIC Controller

Figure 4.3



## Wiring

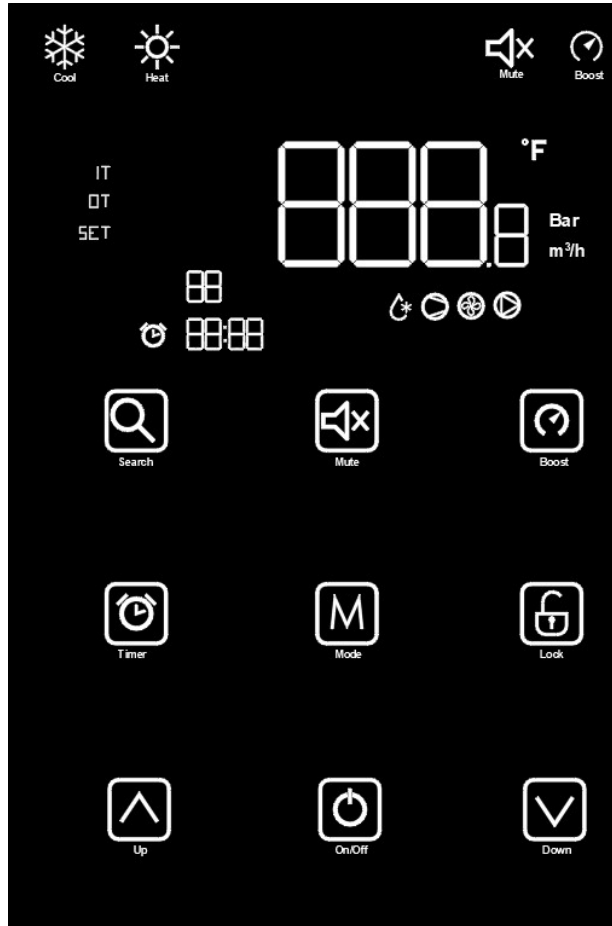
### *Outdoor Unit Main Board I/O Interface Description*

No	Label	Description
1	N	Neutral Terminal
2	L	Line Voltage Terminal
3	R003	4-Way Valve Control Terminal
4	R006	Bottom Coil Heat Tape Terminal
5	R007	Crankcase Heat Tape Terminal
6	R008	Spray Valve Terminal
7	AI03	Discharge temp sensor input
8	AI05	Ambient temp sensor Input
9	AI07	Return air temp sensor input
10	AI08	Coil temp sensor input
11	AI10	EVI inlet temp sensor input
12	AI11	EVI outlet temp sensor input
13	AI21	Return air pressure sensor
14	AI22	Discharge pressure sensor
15	DI01	High pressure switch
16	DI02	Low pressure switch
17	DI04	Remote switch
18	DI05	Mode switch
21	CN1	Expansion valve interface
22	CN2	EVI interface
23	485A1/485B1	Indoor Unit 485 Communication interface
24	CN14(485A2/485B2)	Compressor, DC Fan driver board 485 communication interface

## Section 5: Control

**Figure 5.1**

Easy touch-screen display panel allows users to change between heating and cooling modes as well as access parameter and faults.



## Control

### Touch Screen Wire Controller Interface Introduction - Key and Icon Function Instruction

#### Key Function Instruction

Key symbols	Designation	Function
	Mute key	Under the heating mode or heating mode under the automatic mode, the mute key operation is effective and used to enter and exit the mute mode with one click.
	Mode key	It is used to switch the unit mode, temperature setting, and parameter setting. It is also used to "save" when commissioning a unit.
	On-off key	It is used to turn on or turn off, cancel current operation, and return to the last level of operation.
	Up key	It is used to page up, and increase variable value.
	Down key	It is used to page down, and decrease variable value.
	Clock key	It is used as user clock, and to carry out timing setting.
	Cooling symbol	Display when unit is cooling. When in remote mode and no call for heating or cooling, cooling symbol will be displayed.
	Heating symbol	Will display when unit is in heating.
	Defrosting symbol	Display while the unit is in defrost mode.
	Compressor symbol	Display when the compressor is running.
	Water pump symbol	It will display when when the circulation pump is running.
	Fan symbol	It will display when the fans are running.
	Mute symbol	When the timing mute function is started, it keeps bright for a long time. When it is in mute state, it will flash. Or else, it is off.
	Timing symbol	It will display after the user sets the timing, and multiple timing intervals can be set .
	Locking key symbol	When the keyboard is locked, it is on.
	Fault symbol	Will display upon any faults (see faults section).
	Degrees Celsius symbol	When main display area or auxiliary display area displays degrees Celsius, it is on.
	Degrees Fahrenheit symbol	When main display area or auxiliary display area displays degrees Fahrenheit, it is on.
	Setting symbol	When the parameter is adjustable, it is on
	Second symbol	When main display area displays second digit, it is on.
	Minute symbol	When main display area displays minute digit, it is on.
	Hour symbol	When main display area displays hour digit, it is on.

## Section 6: Operation

### Quick Start-up guide

The SIS system can be field commissioned to work in 2 modes, heating/cooling “remote controlled” and Heating cooling remote controlled with DHW heating.

### Heating and Cooling “remote controlled” mode using SSIC or an equivalent aquastat/control for mode and temperature set points:

In this situation, the remote will select and monitor the set point of the buffer tank sending a heating or cooling call when needed to the SIS system. Control wires (field installed) from the remote control will have to be connected from the inside control directly to the outside unit. Terminals 3 and 4 (remote on and off) terminals 5 and 6 (remote heat cool) These are dry contacts and **absolutely no voltage should be introduced.**

The following parameter set points are required. (Heating or cooling mode must be manually selected using the mode button on the indoor unit touch pad and following the menus located in the manual under the “parameters” section)

Parameter H05=1 (remote on/off Enabled)

Parameter P01=0 (when there is an on/off signal call from the remote control the pump icon will indicate display on screen and the pump contacts will close until the call is satisfied)

### Heating/Cooling modes when DHW is required:

Follow initial guidelines and parameters to best suit your installation (remote or non-remote) Then refer to the following parameter settings:

H11=1 (DHW present)

Then please refer to the following for DHW set points:

R11= DHW Set Point

R12= DHW differential to start

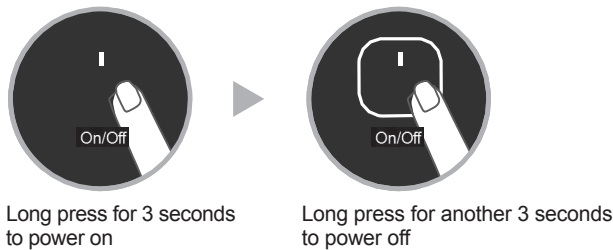
R13= DHW differential to shut off

Figure 6.1 Load Display

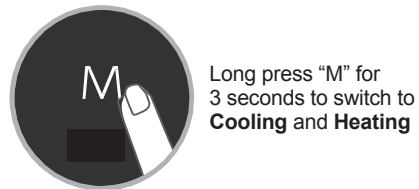


Figure 6.2 Basic Functions

### ON/OFF



### Mode



### Temperature Adjustment (remote mode "off")



Press “Up” arrow to increase the water temperature; press “Down” arrow to decrease the water temperature; press “Mode” to save the settings and press “ON/OFF” to return to the main interface. If there is no operation for 10 seconds, it will not save the settings and return to the main interface.

Cooling temperature adjustment range: 41-77°F



Heating temperature adjustment range: 77-130°F

## Operation

Figure 6.3

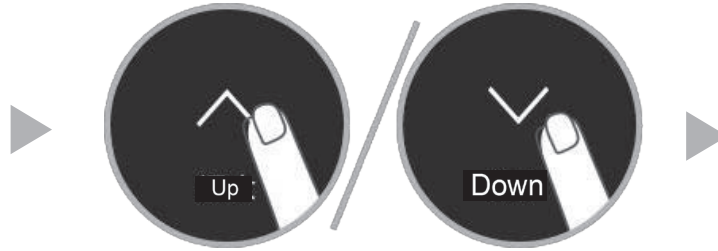


Press “Search” to view water supply, return water, and settings  
Press “Up” or “Down” arrow to switch what to be viewed, and press “ON/OFF” to exit to the main interface

### To View Fault Log



From home screen Long Press “Search” for 3 seconds to view system status'



Press Up/down” arrow to switch the system status to be viewed



Long press “Mode” key for 3 seconds to view fault records

Press “Up” or “Down” arrow to switch what to be viewed, and press “ON/OFF” to exit to the main interface

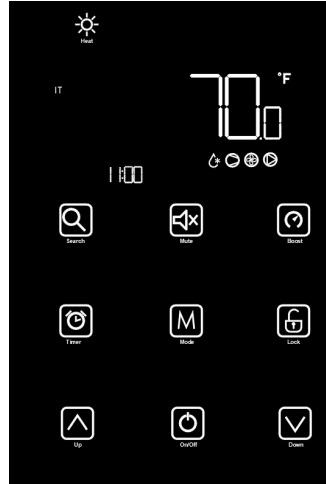


## Operation

From the main screen hold search key for 3seconds to enable status inquiry screen. In this screen the display will indicate if compressor, pump, 4way valve, fan, electric heater or defrost are active (see figure 5.5) By pressing up or down keys the user can view values from the table below.

**Figure 6.4**

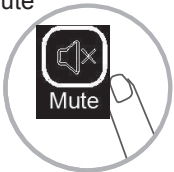
No.	Item	Units
01	Outlet (Supply) Water T	°F
02	Inlet (Return) Water T	°F
03	Compressor Discharge T	°F
04	Outdoor Ambient T	°F
05	Suction Temperature	°F
06	OS Coil Temperature	°F
07	EVI inlet Temp	°F
08	EVI Outlet Temp	°F
09	N/A	
10	N/A	
11	Primary EEV Steps	ea.
12	EVI EEV Steps	ea.
13	Compressor Frequency	Hz
14	Fan 1 Speed	RPM
15	Fan 2 Speed	RPM
16	N/A	
17	N/A	
18	DHW Temperature*	°F
19	Freeze Protection T**	°F



\* If connected

\*\* Indoor Water plumbing

### Mute



By pressing the "Mute" button the fan speeds will reduce to minimize noise levels projected by the outdoor unit. However, in "Mute" speed, the capacity will also be decreased. Press once to turn on and once to turn off.

### Boost



The "Boost" button will allow the user to increase capacity by increasing the compressor speed. The speed is influenced by modulating algorithm's internal to the unit.

### Time



Press the "Up/down" arrow to adjust time

To change the current time settings on the indoor unit, press and hold the "clock" button for 3 seconds. Press the up or down arrow to adjust the hours. Press the "clock" button again to adjust the current minutes. Once the correct time is adjusted, press the "M" key to save. If there is no changes in 10 seconds the clock will time out and no adjustments will be saved.

### Lock Screen



Long press "Lock Screen" for 3 seconds to lock the screen. Long press for 3 seconds again to unlock.

As screen is locked, pressing other keys is invalid. It is recommended to lock the screen after completing the settings to avoid inadvertent touching.

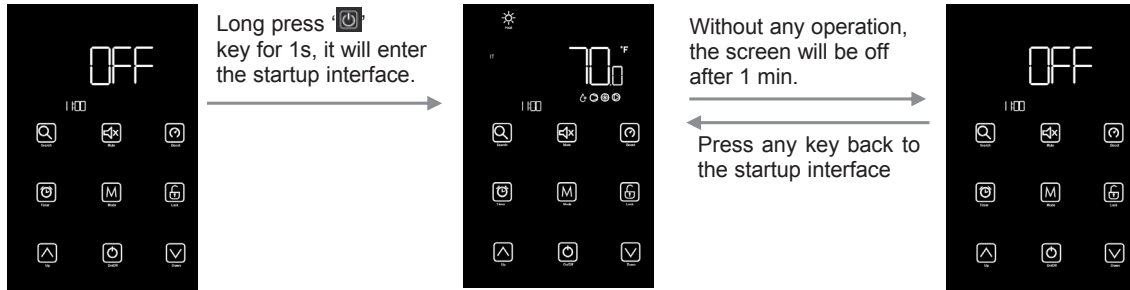
# Operation

Figure 6.5 Key Descriptions

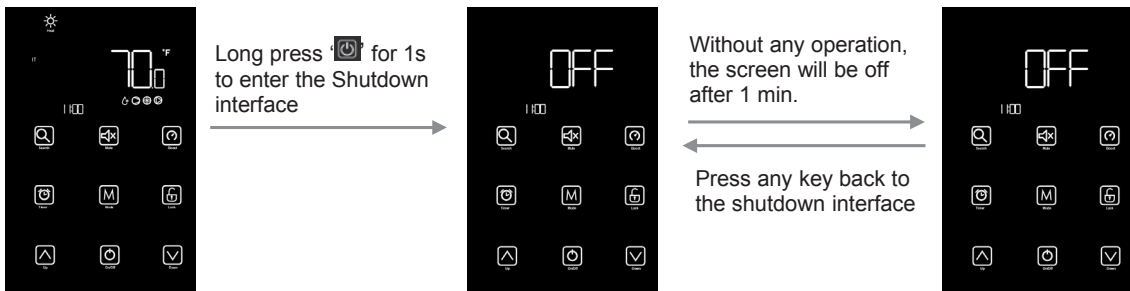
## 1. ON/OFF key

On/Off function is controlled by touch screen controller unless unit is in remote on/off mode.

When the unit is off, press 'ON/OFF' key for 1 second to start it up.

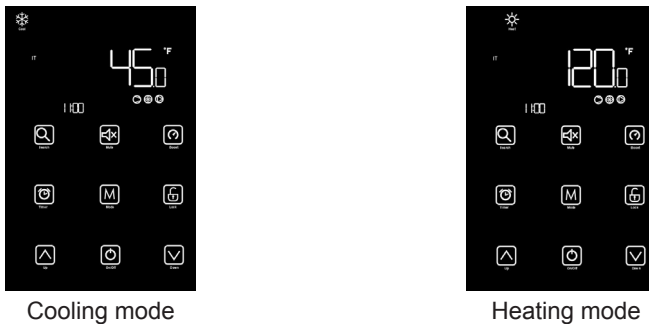


press 'ON/OFF' key for 1 second to shut it down.



## 2. Changing Modes from Heating to Cooling

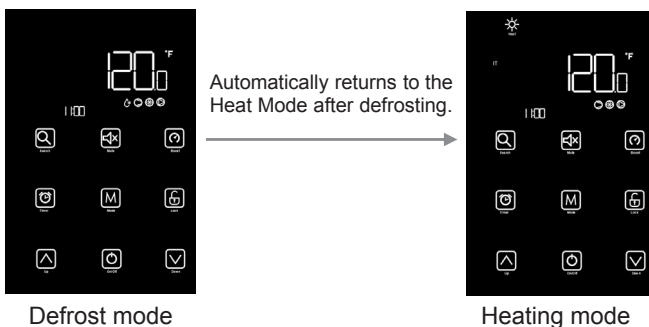
On the main screen, long press "Mode" for 1 second to switch between cooling mode and heating mode.



### Description of operation:

Once the mode has been switched (heating to cooling) the icon will flash for 5 seconds. This confirms the mode has been changed.

When the unit runs in defrost mode, the defrost icon will be displayed. Once the defrost cycle has completed, the unit will automatically return to heat mode.

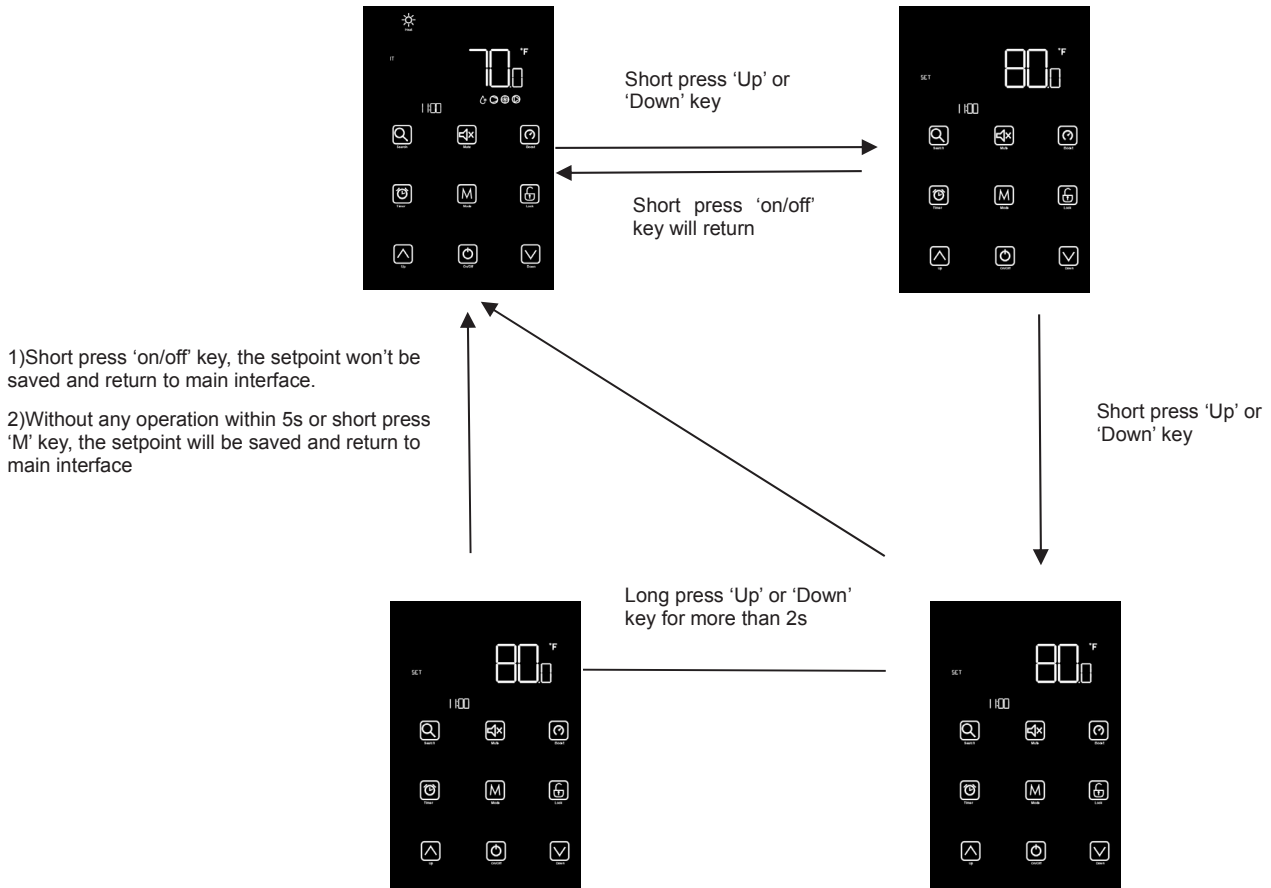


When the unit runs in defrost mode, the unit can be switched manually from heating to cooling. The unit will run in the "new" mode once the defrost cycle has completed.

## Operation

### 3. Temperature Setting

On the main interface, short press 'Up' or 'Down' key, it will enter temperature setting interface. The setpoint will change by pressing 'Up' or 'Down' key.

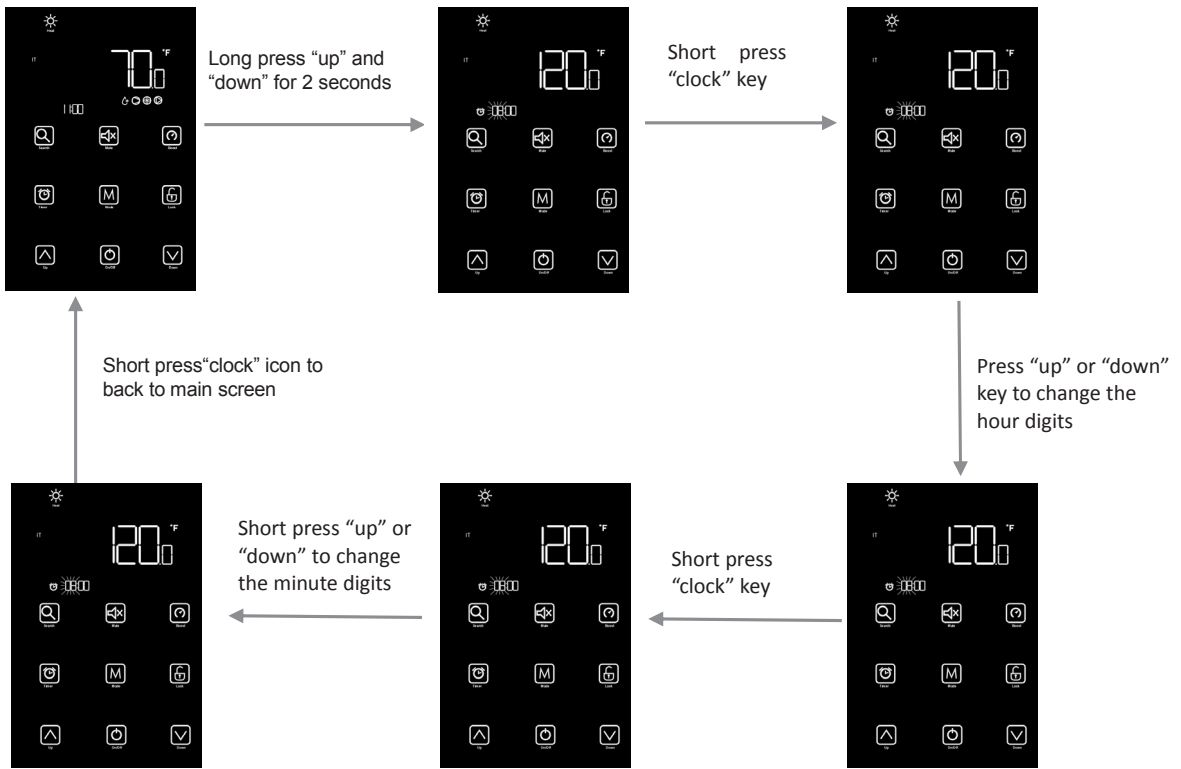


On the temperature setting interface, the system automatically remembers the user setting after 20 seconds without any operation, and returns to the main interface.

## Operation

### 4. Clock Setting

On the main screen, press “up and down” at the same time for 2 seconds to enter clock setting.



## Operation

### 5. Factory Settings

From the home screen:

To adjust or view factory settings, press the "search" key once for 3 seconds, then again for another 3 seconds to enter the Password screen.

The password screen will display "000". Use the up or down arrows to enter password "066". Press the "M" key to accept the password.

The parameter list will begin with Section "A". Use the up or down keys to access the appropriate section based on the chart below. Once the appropriate section is found, press the "M" key to access that sections parameter. For example: If contractor would like to change the temp set-point in heating; Use the up and down to keys to enter a password of "066", press "M" to save the password, then use the up or down keys to locate the section of "R" parameters and press "M". Once selected scroll to "R02" and press "M" again to access the heating temp set-point parameter. Once the parameter has been adjusted, the contractor will press "M" to save. If "M" is not pressed, parameter change will not be saved.

### Parameter List

Section	Code	Description	Units	Range	Default	Notes
A	A01	Minimum Operating Ambient Temp.	Deg F	-58 to 50	-22	Unit will not operate below this outdoor temperature
C	C01	Fixed Compressor Speed	Hz	0 to 120	0	A value of 0 results in modulating variable speed
	C02	Minimum Compressor Speed	Hz	20 to 60	30	Lower end of modulation range
	C03	Maximum Compressor Speed	Hz	30 to 120	90	Upper end of modulation range
	C04	Compressor Model	N/A	-	-	Manufacturer setting, do not alter
D	D01	Min. Time between Defrost Cycles	Min.	5 to 90	45	Defrost cycle will not repeat sooner than this
	D02	Max. duration of a Defrost Cycle	Min.	1 to 20	8	Defrost cycle will not run longer than this
	D03	Coil Temp to Exit Defrost	Deg F	1.8 to 86	45	Defrost cycle will end when coil reaches this temp
	D04	Fixed Coil Temp to Start Defrost	Deg F	-58 to 32	19.4	If Defrost Reset is NOT selected
	D05	Min. Coil Temp to start Defrost	Deg F	-58 to 5	-22	Lower end of Defrost Reset Curve, Coil Temp
	D06	Ambient Temp Spread of Defrost Curve	Deg F	33.8 to 86	33.8	Ambient temp range below 35.6°F of Defrost curve
	D07	Coil Temp Spread of Defrost Curve	Deg F	32 to 86	32	Coil temp range above D05, of Defrost Curve
	D08	Not used				
	D09	Enable Defrost Reset	N/A	0/1	1	0 = Fixed Defrost per D04, 1 = Defrost Reset per D05, D06 & D07
	D10	Aux Electric Heat during Defrost	N/A	0/1	0	0 = No Aux Heat during Defrost, 1=Aux Heat during Defrost
	D11	Compressor Speed during Defrost	Hz	30 to 90	70	Fixed compressor speed during Defrost only
E	E01	EEV Mode	N/A	1	1	Manufacturer setting, do not alter
	E02	EEV Superheat in Heating operation	Deg F	-18 to 18	1.8	Manufacturer setting, do not alter
	E03	EEV initial opening at startup in Heating	Steps	0 to 480	0	Manufacturer setting, do not alter
	E04	EEV Superheat in Cooling operation	Deg F	-18 to 18	7.2	Manufacturer setting, do not alter
	E05	EEV initial opening at startup in Heating	Steps	0 to 480	350	Manufacturer setting, do not alter
	E06	EEV Minumum opening during operation	Steps	0 to 480	100	Manufacturer setting, do not alter
	E07	EEV Opening during Defrost operation	Steps	0 to 480	480	Manufacturer setting, do not alter
	E08	EVI EEV Mode	N/A	0/1	1	Manufacturer setting, do not alter
	E09	EVI EEV Superheat	Deg F	-18 to 18	1.8	Manufacturer setting, do not alter
	E10	EVI EEV initial opening	Steps	0 to 480	150	Manufacturer setting, do not alter
	E11	EVI EEV Minumum opening during opn	Steps	0 to 480	100	Manufacturer setting, do not alter
	F01	Fan Mode	N/A	0/1	1	Manufacturer setting, do not alter
	F02	Fan Quantity	N/A	0/1	0	Manufacturer setting, do not alter
	F	F03	Fixed Fan Speed	RPM	0 to 1,000	0
F04		Max fan speed in Heating Mode	RPM	0 to 1,000	700	Upper end of modulation range
F05		Min fan speed in Heating Mode	RPM	0 to 1,000	200	Lower end of modulation range
F06		Coil Temp for Max Fan Speed, Heating	Deg F	-10 to 104	5	Coil temp at Upper end of fan speed range
F07		Coil Temp for Min Fan Speed, Heating	Deg F	-10 to 104	36	Coil temp at Lower end of fan speed range
F08		Max fan speed in Cooling Mode	RPM	0 to 1,000	700	Upper end of modulation range
F09		Min fan speed in Cooling Mode	RPM	0 to 1,000	200	Lower end of modulation range
F10		Coil Temp for Max Fan Speed, Cooling	Deg F	-10 to 104	105	Coil temp at Upper end of fan speed range
F11		Coil Temp for Min Fan Speed, Cooling	Deg F	-10 to 104	80	Coil temp at Lower end of fan speed range

## Operation

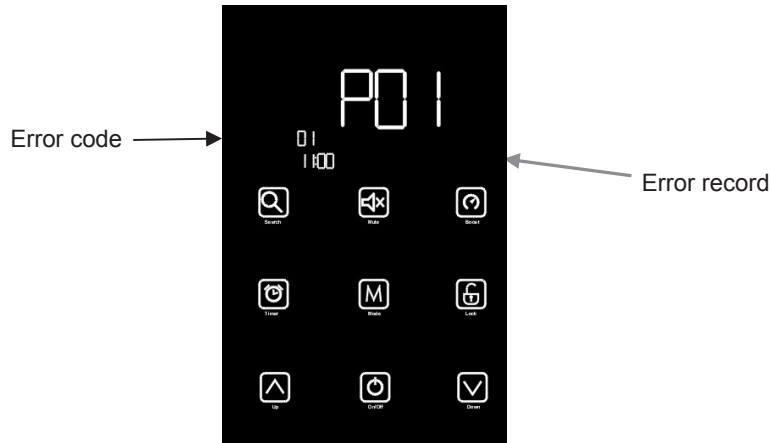
### Parameter List

Section	Code	Description	Units	Range	Default	Notes
H	H01	EVI Operation	N/A	0 to 3	3	0 = EVI Inactive, 1 = EVI in Cooling, 2 = EVI in Heating, 3 = Both
	H02	Running Mode	N/A	0/1	0	Manufacturer setting, do not alter
	H03	Auxiliary Electric Heater	N/A	0/1	0	0 = No Aux Heater, 1 = Aux heater installed and active
	H04	Heat Pump Mode	N/A	0 to 2	0	Manufacturer setting, do not alter
	H05	Remote Enable & Heat Cool selection	N/A	0/1	1	0 = Console touchscreen operation, 1 = Wired remote operation
	H06	Not Used				
	H07	Not Used				
	H08	Not Used				
	H09	Not Used				
	H10	Temperature Measurement Units	N/A	0/1	1	0 = Celsius, 1 = Farenheit
	H11	DHW Operation	N/A	0/1	0	0 = DHW operation disabled, 1 = DHW operation enabled
	H12	Not Used				
	H13	Not Used				
P	P01	Pump Operation	N/A	0 to 2	0	0 = For Console Operation, 1 = For Wired Operation, 2 = Interval
	P02	Interval Pump Off duration	Min.	1 to 120	10	If P01 = 2, Pump Starts every P02 minutes when no call is present
	P03	Interval Pump On duration	Min.	1 to 30	3	If P01 = 2, Pump runs for P03 minutes, or until call is satisfied
	P04	Not used				
R	R01	Supply Temp target setpoint, Cooling	Deg F	R16 to 77	42	Cannot be less than the value of R16
	R02	Supply Temp target setpoint, Heating	Deg F	77 to R15	120	Cannot be greater than the value of R15
	R03	Difference from setpoint to Start Cooling	Deg F	0 to 18	6	Compressor starts in cooling when water temp rises to R01 + R03
	R04	Difference from setpoint to End Cooling	Deg F	0 to 18	2	Compressor stops in cooling when water temp falls to R01 - R04
	R05	Difference from setpoint to Start Heating	Deg F	0 to 18	10	Compressor starts in Heat when water temp falls to R02 - R05
	R06	Difference from setpoint to End Cooling	Deg F	0 to 18	4	Compressor starts in Heat when water temp rises to R02 + R06
	R07	Difference fromsetpoint for Electric Heat	Deg F	0 to 18	4	Electric heaters enabled when water temp is below R02 - R07
	R08	Ambient temp for Electric heat w/Delay	Deg F	-58 to 68	20	Electric heaters available after delay when ambient is below R8
	R09	Time Delay duration	Min.	0 to 120	10	Time delay in minutes for activation of Electric Heaters
	R10	Ambient Temp for Electric heat w/o Delay	Deg F	-58 to 68	-5	Electric heaters available immediately when ambient is below R10
	R11	DHW Temp Setpoint	Deg F	95 to 131	125	Target setpoint of DHW Tank when enabled
	R12	DHW differential to Start	Deg F	0 to 18	10	DHW Starts when Tank temp falls to R11 - R12
	R13	DHW differential to End	Deg F	0 to 18	4	DHW Stops when Tank temp rises to R11 + R13
	R14	Not used				
	R15	Maximum Heating Setpoint	Deg F	113 to 158	140	R02 Cannot be set greater than this value
	R16	Minimum Cooling Setpoint	Deg F	35.6 to 53.6	36	R01 Cannot be set lower than this value
U	U01	Not used				
	U02	Not used				
	U03	Not used				

## Operation

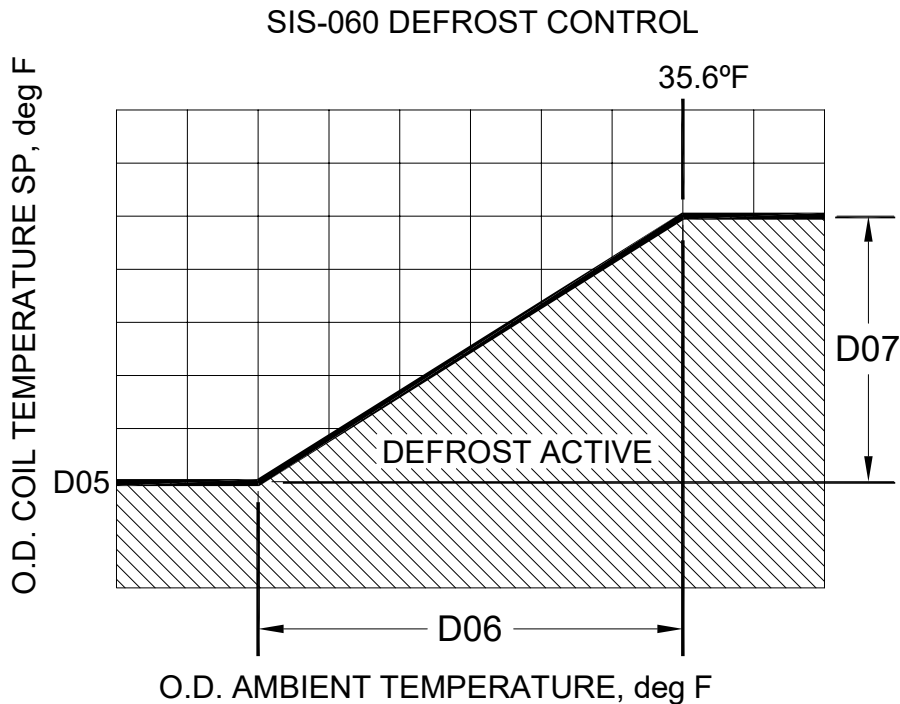
### 6. Error Screen

- 1) When a fault has occurred, the most recent fault will be displayed and should have a "01" as the most recent fault.
- 2) If other faults have occurred press the "up" or "down" keys to display each error. Refer to the fault codes chart for details on each possible error and solution.
- 3) If the screen is off or "asleep" and an error occurs, the screen will automatically "wake-up" or turn on to display the error and will remain on until the error is corrected.



**Figure 6.6 SIS-060 Defrost Control**

The SIS-060 is factory configured to operate the defrost function on a sliding scale. The controller monitors the outdoor ambient temperature, shown below on the horizontal scale, and compares it to the coil temperature, shown on the vertical scale. It then compares the two according to saved parameters D05, D06 and D07. When the conditions fall into the shaded area below the bold line, Defrost will initiate.





## Operation

### **Auxiliary Electric Heater Operation**

When parameter **H03** is set to **1**, the electric heater function is enabled.

The heater will energize when **all (5)** of the below conditions are met.

1. The flow switch has been closed for a minimum of 1 minute.
2. The heater overtemp switch is closed.
3. The compressor is running at 80 Hz or above.
4. The return water temperature is less than **R02** minus **R05** (in heating) or **R11** minus **R12** (in DHW)
5. The ambient temperature is below **R08** and all above conditions have been met for **R09** minutes. **Or** the ambient temperature is below **R10**.

The heater will de-energize when **any** of the below conditions are met.

1. Parameter **H03** is set to **0**
2. The return water is greater than **R02** minus **R05** (in heating) or **R11** minus **R12** (in DHW)
3. The compressor speed is below 50 Hz
4. The ambient temperature rises above **R08** plus 4°F
5. The flow switch opens
6. The heater overtemp switch opens

The heater will operate energize in Defrost operation when **all (3)** of the following conditions are met.

1. Parameter **D10** is set to **1**
2. The heater overtemp switch is closed
3. The flow switch is closed.

### **Domestic Hot Water Operation (Optional configuration)**

The SIS-060 can be configured to provide heat to a Domestic Hot Water System.

The plumbing connections are shown in the Typical System Diagram, Figure 3.11

**Notice:** It is mandatory that the domestic water flow is isolated from the hydronic water flow through the heat pump, by a suitable heat exchanger rated for potable water use. The heat exchanger inside the SIS-060 is not suitable for contact with potable water.

#### **Control Parameter Settings:**

Setting the parameter H11 to a value of 1 enables the DHW mode.

Parameter R11 is the DHW setpoint. This is the temperature of the isolated potable water loop, not the hydronic loop passing through the SIS-060 Heat Exchanger.

Parameter R12 is the Start Differential for DHW operation. When the measured temperature falls below R11 minus R12, the DHW function will start.

Parameter R13 is the End Differential for DHW operation. When the measured temperature rises to R11 plus R13, the DHW function will end.

#### **System wiring:**

Place a 10k NTC Thermistor in the Heated portion of the Potable Water circuit and wire it to the AI/DI 05 inputs of the indoor control according to the Indoor Module Wiring Diagram, Figure 4.2.

Connect a DPDT 120V relay between the output OUT3 and Neutral points according to the Figure 4.2 The contacts of this relay are used to energize the THREE-WAY VALVE and DHW CIRCULATOR.

#### **Operation:**

The DHW function will operate independently of the Heating and Cooling operation. The controller will constantly monitor the DHW temperature, and when it falls below the threshold of the Start Differential, the control will send a 120V signal to the DHW relay, and operate in heating mode to reach the setpoint temperature.

The DHW operation takes priority over Heating or Cooling, and will interrupt those functions when called upon. When the DHW temperature has been satisfied, the SIS-060 will resume Heating or Cooling operation as necessary.

## Section 7: Maintenance/Troubleshooting

**⚠WARNING** All repairs and troubleshooting should be performed by a qualified/licensed technician. Repairs/troubleshooting improperly can void the product warranty and could result in injury, death or premature failure of the product. Please contact Mestek technical support for any issues not covered in the following tables.

### Repair

Condition	Possible Cause	Solution
Reduced heating capacity	Excessively frosted Coil	Ensure Defrost function is enabled and adjusted for local conditons.
	Vegetation or debris too close to the outside coil, blocking airflow	Clear space around the outdoor unit according to the drawings in the Unit Installation section
	Fouled or dirty outside coil	Clean outside coil fins with commercial cleaner. Take care to avoid bending or crushing fins
	Reduced fan performance	Review the fan parameters F04 to F07 to ensure that the fans are reaching maximum speed at design heating conditons. Inspect fans for damaged or missing blades.
	Extremely cold ambient temperature	It is normal for the heating capacity to be reduced as the outdoor temperature falls.
Excessive frost on outside coil in heating	Some frost visible on the fins is normal, but excessive ice blockinig airflow should be addressed	Ensure Defrost function is enabled and adjusted for local conditons.
	Innacurate Coil Temperature Sensor	Verify Status reading temperature 06 against known device placed on coil outlet plumbing
Reduced Cooling Capacity	Insufficient water flow	Ensure the pump is in good operating conditon, and is able to provide at least 12 GPM against the entire system pressure drop. Check plumbing system for blockage or restristive pipe size or fittings.
	Vegetation or debris too close to the outside coil, blocking airflow	Clear space around the outdoor unit according to the drawings in the Unit Installation section
	Fouled or dirty outside coil	Clean outside coil fins with commercial cleaner. Take care to avoid bending or crushing fins
	Reduced fan performance	Review the fan parameters F08 to F11 to ensure that the fans are reaching maximum speed at design cooling conditons. Inspect fans for damaged or missing blades.
Abnormal Compressor noise	Liquid slugging due to overcharged refrigeration system	Ensure the system is charged by weight of refrigeration, with adjustments according to unit Rating Label and SIS Charging Table
	Excessive Discharge Pressure	Ensure sufficient outdoor airflow in Cooling, or indoor water flow in Heating Supply water temperature should not exceed 140 deg F
	Low input voltage	Ensure line voltage is a minimum of 220V during steady state operation
	Damaged or failed compressor	Contact Technical Support

## Maintenance/Troubleshooting

### Faults Query

Display	Corresponding Status Display	Fault	Cause	Troubleshooting	Corrective Action
P01	01	Return Water Temp Sensor Fault	Failed or Disconnected Sensor	Check wiring, check sensor for open or shorted condition	Repair wiring or replace sensor
P02	02	Supply Water Temp Sensor Fault	Failed or Disconnected Sensor	Check wiring, check sensor for open or shorted condition	Repair wiring or replace sensor
P03	05	Coil Temperature Sensor Fault	Failed or Disconnected Sensor	Check wiring, check sensor for open or shorted condition	Repair wiring or replace sensor
P04	04	Ambient Temp Sensor Fault	Failed or Disconnected Sensor	Check wiring, check sensor for open or shorted condition	Repair wiring or replace sensor
P07	05	Suction Temp Sensor Fault	Failed or Disconnected Sensor	Check wiring, check sensor for open or shorted condition	Repair wiring or replace sensor
P08	03	Discharge Temp Sensor Fault	Failed or Disconnected Sensor	Check wiring, check sensor for open or shorted condition	Repair wiring or replace sensor
P11	07	EVI Inlet Temp Sensor fault	Failed or Disconnected Sensor	Check wiring, check sensor for open or shorted condition	Repair wiring or replace sensor
P12	08	EVI Outlet Temp Sensor fault	Failed or Disconnected Sensor	Check wiring, check sensor for open or shorted condition	Repair wiring or replace sensor
E01	-	High Pressure safety switch	Discharge Pressure too High	Switch opens on fault, closes when pressure returns to normal	Determine and address cause of High Pressure
			Switch failed or disconnected	Circuit does not close when pressure returns to normal	Repair wiring or replace switch
E02	-	Low Pressure safety switch	Suction Pressure too Low	Switch opens on fault, closes when pressure returns to normal	Determine and address cause of Low Pressure
			Switch failed or disconnected	Circuit does not close when pressure returns to normal	Repair wiring or replace switch
E03	-	Flow Switch	Insufficient Water Flow	Check pump size and operation, remove air from the system	Purge air and provide sufficient water flow
			Switch failed or disconnected	Confirm switch closes when flow is correct. Check wiring	Repair wiring or replace switch
E19	19	Indoor plumbing freeze protection, Class 1	Indoor plumbing near or below freezing	Normal protection, indoor module should be protected from freezing protection.	Locate the Indoor module where it is not exposed to freezing temperatures.
E20	19	Indoor plumbing freeze protection, Class 2	Indoor plumbing near or below freezing	Normal protection, indoor module should be protected from freezing protection.	Locate the Indoor module where it is not exposed to freezing temperatures.
E07					
P81		Compressor Overload			
E44	04	Outdoor Ambient Temp too low	Temp below A01 setpoint	Normal protection. Unit will not run at extreme cold temperatures.	Operate unit when outdoor temp is above A01. Otherwise engage backup heat source.
E21	-	Input Power under voltage	Voltage drops too low under load	Measure Line to Line voltage at the unit, should not drop below 220V at full load.	Ensure power supply and conductors are capable of delivering sufficient power. Install a Buck/Boost transformer if supply cannot maintain 220V.
E22	-	Overcurrent Protection Alarm	Unit drawing too much current	Measure Outdoor Module current. Should not exceed 40A	Ensure sufficient indoor water flow in Heating. Ensure sufficient outdoor airflow in Cooling.
E23	-	Overcurrent Protection Shutdown	Unit drawing too much current	Measure Outdoor Module current. Should not exceed 40A	Ensure sufficient indoor water flow in Heating. Ensure sufficient outdoor airflow in Cooling.
E24	-	DC Bus overvoltage protection	Electronic control fault	Contact Technical Support	Replace faulty control component
E25	-	DC Bus undervoltage protection	Electronic control fault	Contact Technical Support	Replace faulty control component

## Maintenance/Troubleshooting

### Faults Query

Display	Corresponding Status Display	Fault	Cause	Troubleshooting	Corrective Action
E27	-	IPM Overcurrent protection	Electronic control fault	Contact Technical Support	Adjust or replace faulty control component
E28	-	IPM Overtemp protection	Electronic control fault	Contact Technical Support	Adjust or replace faulty control component
E29	-	Radiator Temp Sensor Fault	N/A	Reserved, does not apply to this unit	Reserved, does not apply to this unit
E30	-	Power Component Overheat protection	Excessive heat inside cabinet	Check indoor and outdoor moduled for extreme temperature.	Ensure sufficient cooling airflow through cabinet. Replace faulty component.
E31					
E32	-	IPM Abnormal Current	Electronic control fault	Contact Technical Support	Replace faulty control component
E33	-	Compressor Overcurrent Shutdown	Excess current draw by compressor	Measure compressor current at full load. Should not exceed 36A	Inspect compressor and wiring.
E34	-	Compressor Overcurrent Alarm	Excess current draw by compressor	Measure compressor current at full load. Should not exceed 36A	Inspect compressor and wiring.
E35	-	Input voltage phase loss	Weak leg of 3 phase to compressor	Check 3 phase power between Inverter board and the compressor	Replace compressor or inverter board
E36	-	Compressor failed to start	Electronic control fault	Contact Technical Support	Replace faulty control component
E37	-	DSP and COMM board fault	Communication fault	Check communication wires, cycle power	Repair or replace control wire connections
E38	-	DSP and PFC board fault	Communication fault	Check communication wires, cycle power	Repair or replace control wire connections
E39	-	Abnormal voltage sampling	Electronic control fault	Contact Technical Support	Replace inverter driver board
E40	-	EEPROM fault	Electronic control fault	Contact Technical Support	Replace EEPROM Chip
E41	-	Compressor flux weakening	Electronic fault condition	Cycle input power	Restart after power down
E42	-	Driver board 15V voltage fault	Board voltage too low or high	Contact Technical Support	Replace faulty control component
E45	-	PFC fault	Inverter driver board fault	Contact Technical Support	Replace inverter driver board
E46	-	Fan 1 fault	Fain fails to start due to mechanical damage	Check for damage or interference	Clear interference or replace damaged component
E47	-	Fan 2 fault	Fain fails to start due to mechanical damage	Check for damage or interference	Clear interference or replace damaged component
EE8	-	Communication fault between drive board and main board	Communication fault	Check RS485 wiring between driver board and main board (in Outdoor module)	Repair or correct RS485 wiring or polarity
E08	-	Communication fault between touchscreen display and main board	Communication fault	Check RS485 wiring between touchscreen display and main board (in Indoor module)	Repair or correct RS485 wiring or polarity
E09	-	Communication fault between Indoor and Outdoor module	Communication fault	Check RS485 wiring (suplied with refrigerant linset) between indoor and outdoor modules.	Repair or correct RS485 wiring or polarity

## Maintenance/Troubleshooting

### Replacement Parts

Part No	Description	Indoor	Outdoor
45W41-WG1300-01	PANEL, GLASS FRONT	X	
45W11-WG1301-01	OVERLAY, TOUCHSCREEN	X	
45W09-WG1302-01	DISPLAY, TOUCHSCREEN	X	
45W40-WG1303-01	ADAPTER, SAE FLARE, -10	X	
45W40-WG1304-01	ADAPTER, SAE FLARE, -06	X	
45W11-WG1305-01	FLOW SWITCH	X	
45W41-WG1306-01	MOUNTING PANEL, REAR	X	
45W41-WG1307-01	SHELL, ENCLOSURE	X	
45W50-WG1308-01	HEAT EXCHANGER, TUBE IN SHELL	X	
45W41-WG1309-01	PANEL, BOTTOM	X	
45W41-WG1310-01	DOOR, FRONT ACCESS	X	
45W09-WG1311-01	CONTROL BOARD	X	
45W09-WG1312-01	TERMINAL, POWER SUPPLY	X	
45W41-WG1313-01	ELECTRICAL COMPARTMENT	X	
45W09-WG1314-01	TERMINAL BLOCK, 8 POSITION	X	
45W09-WG1315-01	TERMINAL, JUMPER	X	
45W28-WG1316-01	RELIEF VALVE, WATER PRESURE	X	
45W28-WG1317-01	RELIEF VALVE, REFRIGERANT	X	
45W41-WG1318-01	FAN PANEL		X
45W41-WG1319-01	BASE PLATE		X
45W41-WG1320-01	STRUT, FAN SUPPORT		X
45W50-WG1321-01	HEAT EXCHANGER, FINNED COIL		X
45W41-WG1322-01	COVER, TOP		X
45W41-WG1323-01	SUPPORT, FINNED COIL		X
45W41-WG1324-01	PANEL, DIVIDER		X
45W41-WG1325-01	MOUNTING PLATE, CONTROL BOARD		X
45W41-WG1326-01	BRACKET, SHUT-OFF VALVES		X
45W09-WG1327-01	INVERTER DRIVER BOARD, COMPRESSOR		X
45W09-WG1328-01	REACTOR, EMI		X
45W09-WG1329-01	FILTER, INVERTER EMI		X
45W05-WG1330-01	PLUG, RUBBER		X
45W40-WG1331-01	TEST PORT, HIGH PRESSURE		X
45W19-WG1332-01	INSERT, LIFT HANDLE		X
45W40-WG1333-01	ADAPTER, CONDENSATE DRAIN		X
45W41-WG1334-01	PANEL, CORNER ACCESS		X
45W28-WG1335-01	SHUT-OFF VALVE, VAPOR		X
45W41-WG1336-01	PANEL, FRONT ACCESS		X
45W41-WG1337-01	BRACKET, HEAT EXCHANGER		X
45W28-WG1338-01	SHUT-OFF VALVE, LIQUID LINE		X
45W28-WG1339-01	REVERSING VALVE		X
45W33-WG1340-01	COMPRESSOR		X
45W28-WG1341-01	CHECK VALVE ASSEMBLY		X
45W40-WG1342-01	WYE, 0.5 COPPER		X
45W41-WG1343-01	BRACKET, CHECK VALVE ASSEMBLY		X
45W50-WG1344-01	HEAT ECHANGER, EVI		X
45W40-WG1345-01	ACCESS PORT, STRAIGHT		X
45W40-WG1346-01	ACCESS PORT, 90 DEG.		X
45W11-WG1347-01	LIMIT SWITCH, LOW PRESSURE		X
45W11-WG1348-01	LIMIT SWITCH, HIGH PRESSURE		X
45W32-WG1349-01	FAN GUARD		X
45W28-WG1350-01	EEV, PRIMARY		X
45W34-WG1351-01	IMPELLER, AXIAL FAN		X
45W28-WG1352-01	EEV, EVI		X
45W31-WG1353-01	MOTOR, AXIAL FAN		X
45W32-WG1354-01	MOUNT, FAN MOTOR		X
45W41-WG1355-01	PANEL, ELECTRICAL COMPARTMENT		X
45W09-WG1356-01	EC DRIVE, FAN MOTOR		X
45W09-WG1357-01	END PLATE, TERMINIAL STRIP		X
45W09-WG1358-01	TERMINAL, FEED THROUGH, 1 POLE		X
45W09-WG1359-01	TERMINAL, FEED THROUGH, 2 POLE		X
45W09-WG1360-01	TERMINAL BLOCK, POWER INLET		X
45W48-WG1361-01	CONTROL BOARD, PC8002		X



## Limited Warranty

### SpacePak "Solstice Inverter" Series Air to Water Heat Pumps

Subject to the terms and conditions of this Limited Warranty Statement (the "Limited Warranty"), SpacePak warrants to the original purchaser of the "Solstice Inverter" Series (as used herein, "System" shall mean the Solstice Inverter outdoor and indoor components connected via refrigerant piping and electrical wiring purchased on or after February 1, 2021 from a licensed HVAC contractor, installed by such contractor in accordance to local and National regulations in the continental U.S., Alaska, Hawaii, and Canada and registered on SpacePak's website located at [www.SpacePak.com/warranty](http://www.SpacePak.com/warranty) that:

- 1) The parts are warranted for a period of two (2) years to the original owner of the system. If any parts should prove defective due to improper workmanship and/or material for a period of two (2) years from the date of installation, SpacePak will replace any defective part without charge for that part. Replacement parts are warranted for the remainder of the original 2-year warranty period. Parts used as replacement may be of like kind and quality and may be new or remanufactured. Defective parts must be available for SpacePak in exchange for the replacement parts and become the property of SpacePak.
- 2) The compressor is warranted for a period of five (5) years to the original owner of the system. If the compressor should prove defective due to improper workmanship and/or material for a period of five (5) years from the date of installation, SpacePak will replace the defective compressor without charge for the compressor. Replacement compressors are warranted for the remainder of the original 5-year warranty period. Compressors used for replacement may be of like kind and quality and may be new or remanufactured. Defective compressors must be made available to SpacePak in exchange for the replacement compressor and become the property of SpacePak.
- 3) **Notwithstanding the foregoing, if the System is installed in a residential single-family home by a SPACEPAK CERTIFIED CONTRACTOR the parts will be warranted for five (5) years and compressor will be warranted for a period of ten (10) years, to the original owner, so long as the original owner resides in the home.** Specifically, if any parts and/or the compressor should prove defective due to improper workmanship and/or material for the period listed above from the date of installation, SpacePak will replace any defective parts or compressor without charge for the part or compressor. The replacement parts and/or compressor are warranted for the remainder of the original warranty period. Parts and/or compressors used for replacement may be of like kind and quality and may be new or remanufactured. Defective parts and/or compressors must be made available to SpacePak in exchange for the replacement parts and become the property of SpacePak.

\*For any Solstice equipment that is non-inverter, please refer to warranty located in the equipment original installation manual.

### SpacePak Small Duct High Velocity Air Handlers and Hydronic Fan Coils

Subject to the terms and conditions of this Limited Warranty Statement (the "Limited Warranty"), SpacePak warrants to the original purchaser of the Small Duct High Velocity Air Handlers and hydronic fan coils (as used herein, "System" shall mean the air handlers or fan coils) purchased on or after February 1, 2021 from a licensed HVAC contractor and installed by such contractor in accordance to local and National regulations in the continental U.S., Alaska, Hawaii, and Canada and registered on SpacePak's website located at [www.SpacePak.com/warranty](http://www.SpacePak.com/warranty) that:

- 1) The parts are warranted for a period of one (1) year to the original owner of the system. If any parts should prove defective due to improper workmanship and/or material for a period of one (1) year from the date of installation, SpacePak will replace any defective part without charge for that part. Replacement parts are warranted for the remainder of the original 1-year warranty period. Parts used as replacement may be of like kind and quality and may be new or remanufactured. Defective parts must be available for SpacePak in exchange for the replacement parts and become the property of SpacePak.
- 2) Notwithstanding the foregoing, if the System is installed in a residential single-family home by a SPACEPAK CERTIFIED CONTRACTOR the parts will be warranted for five (5) years, to the original owner, so long as the original owner resides in the home. Specifically, if any parts should prove defective due to improper workmanship and/or material for the period listed above from the date of installation, SpacePak will replace any defective parts or compressor without charge for the part or compressor. The replacement parts are warranted for the remainder of the original warranty period. Parts used for replacement may be of like kind and quality and may be new or remanufactured. Defective parts must be made available to SpacePak in exchange for the replacement parts and become the property of SpacePak.

### SpacePak Buffer Tanks

The "Manufacturer" warrants to the original owner at the original installation site that the Hydronic Buffer Tanks (the "Product") will be free from defects in material or workmanship for a period not to exceed ten (10) years from the startup, provided the product is installed in accordance with the manufacturers installation instructions. If upon examination by the Manufacturer the Product is shown to have a defect in material or workmanship during the warranty period, the Manufacturer will repair or replace, at its option, that part of the Product which is shown to be defective.

### Items 4-6 apply to ALL SpacePak products

- 4) **NO LABOR.** These limited warranties do NOT include labor or any other costs incurred for service, maintenance, repair, removing, replacing, installing, complying with local building and electric codes, shipping or handling, or replacement of the System/Products, compressors or any other parts. For items that are designed to be maintained or replaced by the original owner, the original owner is solely responsible for all labor and other costs of maintaining, installing, replacing, disconnecting or dismantling the System/Products and parts in connection with owner-required maintenance. Please consult the applicable technical documentation for regularly suggested maintenance procedures.
- 5) **PROPER INSTALLATION.** This Limited Warranty applies only to Systems/Products that are installed by contractors who are licensed for HVAC installation under applicable local and state law, and who install the Systems/Products in accordance with (i) all applicable building codes and permits; (ii) SpacePak's installation and operation instructions; and (iii) good trade practices.
- 6) **BEFORE REQUESTING SERVICE,** please review the applicable technical documentation to insure proper installation and correct customer control adjustment for the System/Products. If the problem persists, please arrange for warranty service.
  - a. **TO OBTAIN WARRANTY SERVICE:**
    - i. Contact the licensed contractor who installed the System/Products or the nearest licensed contractor, dealer, or distributor (whose name and address may be obtained on our website at [www.SpacePak.com](http://www.SpacePak.com) of any defect within the applicable warranty time period.
    - ii. Proof of the installation date by a licensed contractor is required when requesting warranty service. Present the sales receipt, building permit or other document which establishes proof and date of installation. In the absence of acceptable proof, this Limited Warranty shall be deemed to begin one hundred twenty (120) days after the date of manufacture stamped on the System/Products.
    - iii. This Limited Warranty applies only to System/Products purchased on or after February 1, 2021 only while the System/Products remains at the site of the original installation, and only to locations within the continental United States, Alaska, Hawaii and Canada.
    - iv. Shipment, to the Manufacturer, of that part of the Product thought to be defective. Goods can only be returned with prior written approval from the Manufacturer. All returns must be freight prepaid. Determination, in the reasonable opinion of the Manufacturer, that there exists a defect in material or workmanship.
  - b. **THIS LIMITED WARRANTY DOES NOT COVER:** property damages, malfunction or failure of the System/Products, or personal injury caused by or resulting from: (a) accident, abuse, negligence or misuse; (b) operating the System/Products in a corrosive or wet environment, including those containing chlorine, fluorine or any other hazardous or harmful chemicals or environmental factors, including sea- or salt-water; (c) installation, alteration, repair or service by anyone other than a licensed contractor or other than pursuant to the manufacturer's instructions; (d) improper matching of System/Products components; (e) improper sizing of the System/Products; (f) improper or deferred maintenance contrary to the manufacturer's instructions; (g) physical abuse to or misuse of the System/Products (including failure to perform any maintenance as described in the Operation manual, or any System/Products damaged by excessive physical or electrical stress; (h) System/Products that have had a serial number or any part thereof altered, defaced or removed; (i) System/Products used in any manner contrary to the Operation Manual; (j) freight damage; or (k) events of force majeure or damage caused by other external factors such as lightning, power surges, fluctuations in or interruptions of electrical power, rodents, vermin, insects, or other animal- or pest-related issues.
  - c. **THIS LIMITED WARRANTY ALSO EXCLUDES:** (a) SERVICE CALLS WHERE NO DEFECT IN THE SYSTEM/PRODUCTS COVERED UNDER THIS WARRANTY IS FOUND; (b) System/Products installation or set-ups; (c) Adjustments of user controls; (d) System/Products purchased or installed outside the continental United States, Alaska, Hawaii and Canada; or (e) System/Products purchased or installed prior to **February 1, 2021**. Consult the operating instructions for information regarding user controls.



Split Inverter Air-to-Water Heat Pump





IN UNITED STATES: 260 NORTH ELM ST. WESTFIELD, MA 01085 800-465-8558  
IN CANADA: 7555 TRANMERE DRIVE, MISSISSAUGA, ONTARIO, L5S 1L4 (905) 670-5888