

CABINET UNIT HEATER SUBMITTAL DATA

CBS-C-15

Ceiling Mounted Units (Non Recessed Only) - Models C

PIPING AND MOUNTING CONNECTIONS SHOWN ARE TYPICAL FOR ALL AIR FLOW ARRANGEMENTS SEE OTHER SIDE.

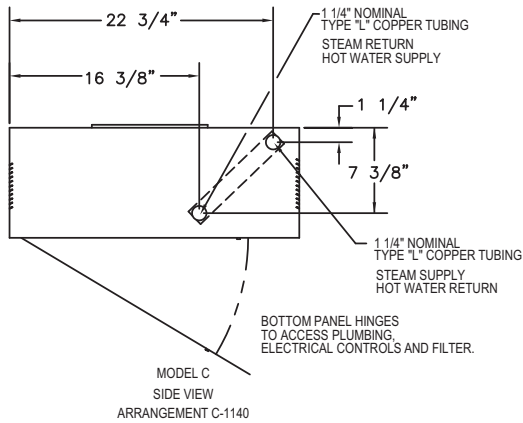

STANDARD ONE ROW COIL PIPING DIMENSIONS.
(SHOWN ABOVE)

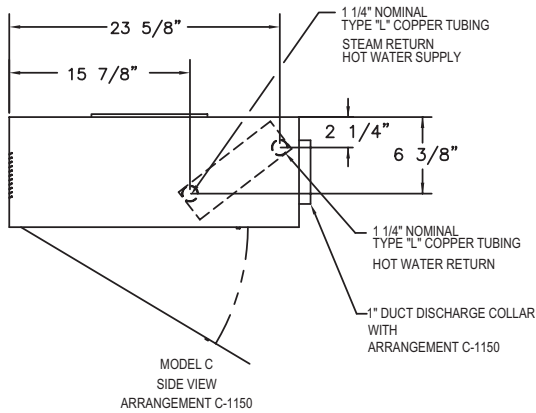

TWO ROW COIL PIPING DIMENSIONS
(SHOWN ABOVE)

THIS DATA SHEET SHOWS CEILING MOUNTED UNITS
(Non Recessed ONLY) MODELS "C".

PIPING AND MOUNTING CONNECTIONS SHOWN ARE TYPICAL
FOR ALL AIR FLOW ARRANGEMENTS.

SEE PAGE 6 for other air flow arrangements.

◊ MAXIMUM RECESS DEPTH
MODELS C1140, C1150, C1160, C1180 ONLY.

SECTION "A"- "A"

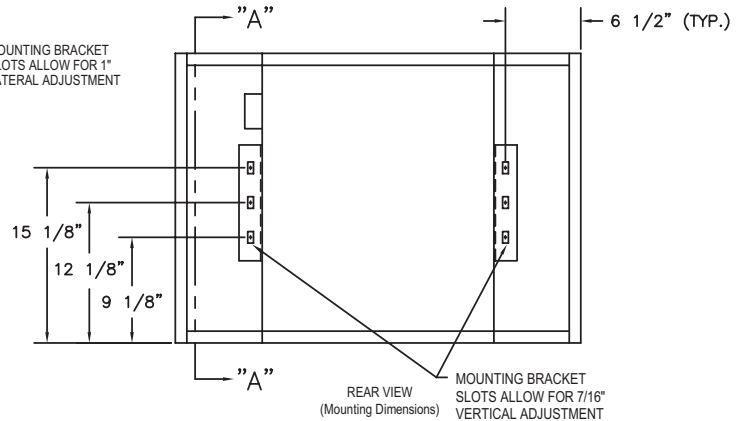
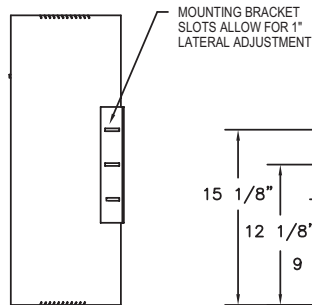

MODEL C
FRONT/BOTTOM VIEW

PROJECT: _____
 LOCATION: _____
 ARCHITECT: _____
 ENGINEER: _____
 CONTRACTOR: _____
 PO NUMBER: _____
 DATE: _____

CAT00202A



STERLING
COMMERCIAL HYDRONIC PRODUCTS

260 NORTH ELM STREET / WESTFIELD, MA 01085
 TEL: (413) 568-9571 FAX: (413) 562-8437
 www.sterlingheat.com



A MESTEK COMPANY

CABINET UNIT HEATERS RATINGS AND SPECIFICATIONS

ENTERING WATER - 200°F
ENTERING AIR - 60°F

TABLE 1

UNIT SIZE		02	03	04	06	08	10	12	14
Heating Cap. - Hot Water	MBH	16.4	22.8	29.8	48.0	54.5	62.0	75.6	78.5
	20_WTD GPM	1.64	2.28	2.98	4.80	5.46	6.20	7.56	7.85
High Cap. - Coil 2 Row Heating Cap. - Hot Water	MBH	25.8	35.4	46.3	69.8	87.6	101.8	119.8	128.6
	20_WTD GPM	2.58	3.54	4.63	6.98	8.76	10.18	11.98	12.86
Heating Cap. - Steam 2 PSIG Standard	MBH	22.6	31.4	41.0	66.1	75.1	85.4	104.1	108.2
	EDR	94	131	171	276	313	356	434	451
	Coil Connections Cond. LB/HR	23.4	32.5	42.4	68.4	77.7	88.4	107.7	112
Coil:	Number Fins Per Inch	12	12	12	12	12	12	12	12
	Face Area-Ft. ²	97	1.5	1.8	2.6	2.8	3.1	3.6	4.4
	Coil Connections	1-1/4CU	1-1/4CU	1-1/4CU	1-1/4CU	1-1/4CU	1-1/4CU	1-1/4CU	1-1/4CU
	Blowers:								
Standard PSC Motor:	Number	1	1	2	2	3	3	4	4
	Diameter/Width (In)	5-3/4 x 7	5-3/4 x 7	5-3/4 x 7	5-3/4 x 7	5-3/4 x 7	5-3/4 x 7	5-3/4 x 7	5-3/4 x 7
Fan Speed Control	HP	1/15	1/15	1/10	1/10	1 @ 1/10 1 @ 1/15	1 @ 1/10 1 @ 1/15	1/10	1/10
	RPM: High	1050	1050	1050	1050	1050	1050	1050	1050
	Low	875	875	875	875	875	875	875	875
	Number	1	1	1	1	2	2	2	2
Optional ECM Motor:	Volts/Phase/Hz	115/1/60	115/1/60	115/1/60	115/1/60	115/1/60	115/1/60	115/1/60	115/1/60
	Amperes	0.8	0.8	1.4	1.4	2.2	2.2	2.8	2.8
	Standard Mtr	VAR.	VAR.	VAR.	VAR.	VAR.	VAR.	VAR.	VAR.
	CFM: High	230	335	430	630	860	1060	1230	1410
Fan Speed Control	Low	185	270	345	505	685	845	985	1130
	HP	1/15	1/15	1/15	1/15	1/10	1/10	1/4	1/4
	Number	1	1	1	1	2	2	2	2
	Volts/Phase/Hz	120/1/60	120/1/60	120/1/60	120/1/60	120/1/60	120/1/60	120/1/60	120/1/60
Fan Speed Control	Amperes	0.45	0.45	0.65	0.85	1.5	1.95	2.8	2.8
	ECM Mtr	3 - SPEED	3 - SPEED	3 - SPEED	3 - SPEED	3 - SPEED	3 - SPEED	3 - SPEED	3 - SPEED
	CFM: High	230	335	430	630	860	1060	1230	1410
	Med	160	240	375	440	590	740	850	980
Filter:	Low	120	150	280	320	450	560	640	730
	No.	1	1	1	1	1	1	1	1
	Type	PERM.	PERM.	PERM.	PERM.	PERM.	PERM.	PERM.	PERM.
	Length (In)	19-3/4	27-3/4	31-3/4	43-3/4	45-3/4	50-3/4	57-3/4	69-3/4
dB, Level 18" From Unit	Width (In)	8-11/16	8-11/16	8-11/16	8-11/16	8-11/16	8-11/16	8-11/16	8-11/16
	Thickness (In)	1/2	1/2	1/2	1/2	1/2	1/2	1/2	1/2
	Length (In)	35	43	47	59	61	66	73	85
Height (In)	25	25	25	25	25	25	25	25	
	Depth (In)	9-1/2	9-1/2	9-1/2	9-1/2	9-1/2	9-1/2	9-1/2	9-1/2

FILTER IDENTIFICATION AND DATA		
SIZE	PART NO.	FILTER SIZE
02	PC1297-2	15/32" x 8 11/16" x 19 3/4"
03	PC1297-3	15/32" x 8 11/16" x 27 3/4"
04	PC1297-4	15/32" x 8 11/16" x 31 3/4"
06	PC1297-6	15/32" x 8 11/16" x 43 3/4"
08	PC1297-8	15/32" x 8 11/16" x 45 3/4"
10	PC1297-10	15/32" x 8 11/16" x 50 3/4"
12	PC1297-12	15/32" x 8 11/16" x 57 3/4"
14	PC1297-14	15/32" x 8 11/16" x 69 3/4"

SIZE	DIM "L"	DIM "W"
02	35"	18 1/8"
03	43"	26 1/8"
04	47"	30 1/8"
06	59"	42 1/8"
08	61"	44 1/8"
10	66"	49 1/8"
12	73"	56 1/8"
14	85"	68 1/8"

CABINET UNIT HEATERS SHIPPING WEIGHT (LBS)

STYLE	SIZE							
	02	03	04	06	08	10	12	14
C	97	115	128	157	175	185	207	234

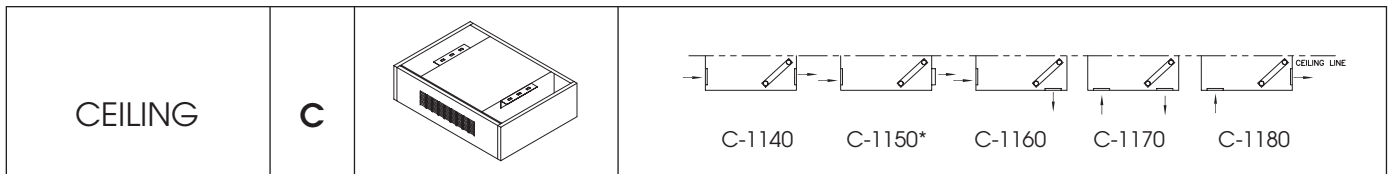

*Arrangement is specifically designed for duct use. See Options 114 and 115.

CABINET UNIT HEATERS HEATING CAPACITIES

TABLE II — STANDARD COIL

ENTERING WATER - 200°F
ENTERING AIR - 60°F

UNIT SIZE	GPM	WATER PD/FT	HIGH FAN SPEED				LOW FAN SPEED			
			CFM	MBH	WTD	FAT	CFM	MBH	WTD	FAT
02	.84	.06	230	14.3	34.0	117	185	12.9	30.6	124
	1.0	.06		15.1	30.2	120		13.8	27.6	129
	1.5	.15		16.2	21.6	125		15.0	20.0	135
	2.0	.24		17.4	17.4	130		16.1	16.1	140
	2.5	.36		18.8	15.0	135		17.3	13.8	146
03	1.0	.07	335	21.3	42.6	118	270	19.1	38.2	125
	1.5	.16		22.0	26.6	120		19.8	26.4	128
	2.0	.26		22.7	22.7	122		20.1	20.1	129
	2.5	.39		23.5	18.8	125		20.7	16.6	131
	3.0	.55		23.8	15.8	126		21.1	14.1	132
04	1.0	.07	430	21.8	43.6	106	345	19.0	38.0	111
	2.0	.27		26.6	26.6	117		23.9	23.9	124
	2.5	.41		29.0	23.2	122		25.8	20.5	129
	4.0	1.00		30.9	15.4	126		27.4	13.7	133
	5.0	1.45		32.3	12.9	129		28.3	11.3	136
06	2.0	.30	630	40.4	40.4	119	505	35.7	35.7	125
	3.0	.63		44.8	29.8	125		39.8	26.5	133
	4.0	1.10		47.2	23.6	129		41.9	21.0	136
	5.0	1.60		49.4	19.8	132		43.6	17.5	140
	6.0	2.25		50.7	16.9	134		44.6	15.0	142
08	2.0	.31	860	47.1	47.1	110	685	42.0	42.0	117
	3.0	.64		52.2	34.8	115		46.5	31.0	123
	4.0	1.10		53.9	26.9	117		48.3	24.2	125
	6.0	2.25		56.0	18.6	120		49.1	16.4	126
	8.0	3.85		57.8	14.4	122		51.2	12.8	129
10	3.0	.65	1060	55.8	32.7	109	845	50.2	33.5	115
	4.0	1.15		60.4	30.2	112		53.5	26.8	118
	6.0	2.35		62.2	20.7	114		54.7	18.2	120
	8.0	4.00		64.1	16.0	116		56.3	14.1	121
	10.0	6.00		66.0	13.2	117		58.9	11.8	124
12	4.0	1.20	1230	71.5	35.7	113	985	65.1	32.6	131
	6.0	2.50		74.5	24.8	116		66.6	22.2	133
	8.0	4.20		76.7	19.1	117		68.0	17.0	134
	10.0	6.30		77.7	15.5	118		69.0	13.8	135
	12.0	8.85		78.6	13.1	119		69.7	11.6	136
14	3.5	1.00	1410	71.0	40.6	106	1130	66.3	37.9	114
	4.0	1.30		74.1	37.0	108		68.4	34.2	116
	6.0	2.70		77.6	25.9	111		69.9	23.3	117
	10.0	6.80		80.9	16.2	113		72.5	14.5	119
	12.0	9.55		81.7	13.6	113		73.0	12.2	120

CABINET UNIT HEATERS HEATING CAPACITIES

TABLE III — HIGH CAPACITY - 2 ROW COIL

ENTERING WATER - 200°F
ENTERING AIR - 60°F

UNIT SIZE	GPM	WATER PD/FT	HIGH FAN SPEED				LOW FAN SPEED			
			CFM	MBH	WTD	FAT	CFM	MBH	WTD	FAT
02	1.68	.26	225	23.6	27.9	157	180	21.2	25.3	169
	2.0	.34		24.8	24.8	162		22.5	22.5	175
	2.5	.50		25.7	20.6	165		23.5	18.8	180
	3.0	.73		26.6	18.1	169		23.9	16.0	183
	3.5	.96		27.5	15.9	173		24.8	14.1	187
03	1.68	.27	330	30.3	36.0	149	265	27.3	32.5	155
	2.0	.38		33.1	33.1	152		29.7	29.7	163
	2.5	.56		34.3	27.4	156		30.3	24.2	165
	3.0	.77		34.9	23.3	157		30.8	20.5	167
	3.5	.96		35.3	20.2	159		31.8	18.2	170
04	1.68	.30	420	37.2	43.6	142	335	33.5	39.9	152
	2.0	.44		39.5	39.5	147		35.8	35.8	158
	2.5	.59		42.4	33.9	153		37.8	30.2	164
	4.0	1.41		45.4	22.7	160		39.7	19.9	169
	5.0	2.04		46.8	18.7	163		40.8	16.3	172
06	2.0	.45	620	57.6	57.6	146	495	52.7	52.7	158
	3.0	.93		63.1	42.1	154		57.0	38.0	166
	4.0	1.60		66.0	33.0	158		59.7	29.9	171
	5.0	2.30		69.1	27.6	163		61.2	24.5	174
	6.0	3.30		69.5	23.2	164		62.0	20.7	175
08	2.0	.46	845	67.1	67.1	133	675	58.1	58.1	139
	3.0	.95		75.8	50.5	143		68.2	45.5	153
	4.0	1.65		79.3	39.7	146		71.6	35.8	158
	6.0	3.35		82.6	27.5	150		73.4	24.5	160
	8.0	5.60		86.5	21.6	154		75.8	19.0	163
10	3.0	1.00	1040	84.6	56.4	135	830	75.9	50.6	144
	4.0	1.75		90.6	45.3	140		81.2	40.6	150
	6.0	3.50		94.6	31.5	144		84.0	28.0	153
	8.0	5.90		98.6	24.7	147		86.3	21.6	156
	10.0	8.85		101.6	20.3	150		88.9	17.8	159
12	4.0	1.85	1210	105.3	52.7	140	970	93.3	46.7	149
	6.0	3.75		111.6	37.2	145		100.4	33.5	155
	8.0	6.30		115.3	28.8	148		102.8	25.7	158
	10.0	9.45		118.1	23.6	150		105.0	21.0	160
	12.0	13.20		119.8	20.0	151		106.7	17.8	161
14	4.0	2.05	1385	109.8	54.9	133	1110	100.2	50.1	143
	5.0	3.00		114.8	45.9	136		103.5	41.4	146
	6.0	4.15		118.3	39.4	139		106.6	35.5	149
	10.0	10.45		125.8	25.2	144		111.4	22.3	152
	12.0	14.55		127.9	21.3	145		112.2	18.7	153

SPECIFICATIONS & WARRANTY*

*STANDARD CABINET UNIT ONLY

The contractor shall furnish and install Sterling Cabinet Unit Heaters as selected to meet or exceed job requirements. The Cabinet Unit Heaters will conform to the items listed below and be certified under CSA guidelines.

CABINETS

All cabinets will be constructed with 18-gauge cold rolled steel, side panels and top. The front panel shall be furnished in 16-gauge cold rolled steel. It will have 1/2", 1-1/2 pound insulation with one side neoprene coated in front of coil. The internal cabinet shall be furnished in 18-gauge galvanized steel. Adequate work area for installation of control valves or electrical equipment shall be provided on both sides of the internal cabinet.

The cabinet shall be provided with a neutral eggshell baked enamel prime coat as standard. (Available if specified) Powder coated baked enamel, color selected from standard.

All cabinets shall be supplied with adjustable rear mounting brackets which will provide adjustment to correct alignment of the unit at installation to non square or out of true walls, joists, studs or surfaces. Adjustable leveling legs (two each base leg) are available when specified.

RECESSED UNITS

All recessed units shall be supplied with a "Wall Seal" assembly. This assembly shall provide protection to the wall or ceiling construction material. The "Wall Seal" shall be supplied in an eggshell baked enamel prime coat as standard. (When specified) Baked enamel colors may be selected from standard.

CEILING MOUNT OR RECESSED UNITS

All "C" and "RC" units shall be supplied with a hinged front panel. The multiple hinges shall provide full swing through 90°. A safety chain shall be provided as standard to prevent the face panel from swinging fully open accidentally. This chain must be easily detached to allow full access for servicing. Speed control switch will be shipped with wiring diagram for installation where desired.

FILTERS

All filters supplied as standard shall be reusable aluminum media with a 69% arrestance level. Filters shall be slide in type which are locked into position with a cotter pin.

FANS

Fan wheels shall be centrifugal, forward curved, double width of electro galvanized steel. Fan housings shall be of formed galvanized sheet metal.

COILS

STANDARD ONE ROW - The durable mechanically bonded copper/aluminum coil presents the best of today's hydronic heating technology. All element assemblies are submersion tested at factory at 250 PSI and are rated at a working pressure of 300 PSI. All units are designed so that field modifications can be made to reverse the coil position if required.

HIGH CAPACITY COIL - This is a hot water coil designed to provide increased capacity when the required load exceeds that of the standard coil for a given size. Its construction is similar to the standard coil however, there are two rows of tubes. Element assemblies are submersion tested at 250 PSI and are rated at a working pressure of 300 PSI.

MOTORS

Standard PSC motors shall have integral thermal protection and start at 78% of rated voltage. Optional PSC High Static motors will be capable of operating in high static conditions up to 4 inches of water column. All motors shall be factory run-tested and assembled in unit prior to shipping. Optional ECM and high static motors will have a solid state control board and a 3 speed switch. All motors shall be factory run-tested and assembled in unit prior to shipping.

ELECTRICAL

All primary internal wiring shall be done at the factory and every unit shall be factory tested for reliability.

FRESH AIR DAMPERS ON DESIGNATED UNITS ONLY

When desired specify either of the following:

1. Where noted 25% Manual Outside Air Dampers shall be provided. A manually operated damper quadrant shall provide from 0% to 25% outside air through the use of a single blade damper.

2. Where noted 25% Motorized Outside Air Dampers shall be provided. A synchronous motor (115/60/1) interlocked with the blower shall automatically open the outside air damper when blower starts. The single blade damper shall be adjustable from 0% to 25% outside air. When the blower stops or there is a loss of power, the damper shall return to the closed position. A damper override switch shall be provided to prevent damper operation when desired.

WARRANTY

The products in this catalog are warranted by Sterling, to be free from defects in material and workmanship for a period of one (1) year from the date of shipment from Sterling's plant. Sterling's liability under this warranty is limited to replacing or repairing at our option, F.O.B. our plant any defective component or assembly returned to our factory prepaid and with proper return authorization document. All repairs or replacements are made subject to factory inspection. In the interest of product improvement, Sterling reserves the right to make changes without notification.



STERLING
COMMERCIAL HYDRONIC PRODUCTS

260 NORTH ELM STREET / WESTFIELD, MA 01085
TEL: (413) 568-9571 FAX: (413) 562-8437
www.sterlingheat.com



A MESTEK COMPANY