

JVB Slip Jointed Enclosure

Specification

ENCLOSURE:

- STYLE: Flat Top, Front & Top Outlet
 OUTLET: Stamped Louvers
 Pencil Proof
- LENGTHS: 2'0" thru 8'0" in 6" Increments
 MAT'L: 16 Ga. CRS (Std)
 14 Ga. CRS (Opt'l)
 16 Ga. Stainless Steel (Opt'l)
 14 Ga. Stainless Steel (Opt'l)
 14 Ga. Aluminum (Opt'l)
 12 Ga. Aluminum (Opt'l)
- HEIGHT: 14"
 20"
 24"
 30"
 36"
- FINISH: Baked Powder (Std)
 Baked Metallic (Opt'l)

ACCESSORIES:

JV Overlapping Type
 All accessories return to the wall at the bottom and have pre-punched holes for fastening to the wall.

ELEMENT:

- TYPE: Cu/Al (Mechanically Expanded)
- LENGTHS: 2'0" thru 12'6" in 1" Increments for 1" & 1-1/4" Cu.
 2'0" thru 8'0" in 1" Increments for 3/4" Cu.

One End Flared (Std)

See Catalog for Working Pressures

DAMPER:

- Damper Blades Factory Installed
 Knob Damper (Opt'l)
 Tamper Resistant (Opt'l)

BACKPLATE:

- TYPE: Partial B/P
 LENGTHS: 8'0" Only
 MAT'L: 20 Ga. Prepainted (Std)
 18 Ga. Galvannealed (Opt'l)
- TYPE: Full Ht. B/P (Opt'l)
 LENGTHS: 2'0" thru 8'0" in 6" Increments
 MAT'L: 20 Ga. Galvannealed (Opt'l)
 20 Ga. Painted (Opt'l)
 18 Ga. Painted (Opt'l)

AIRSEAL:

- 1/8" x 3/8" Closed Cell (Opt'l)

BRACKETS:

- Water Brkt (with Stand-Off)
 Stand-Off not required with 14", 20", & 24"

- B.B. Hanger, Bracket Mtd
 B.B. Hanger, Wall Mtd
 Wall Mtd B.B. Hanger required for 3rd Tier Element

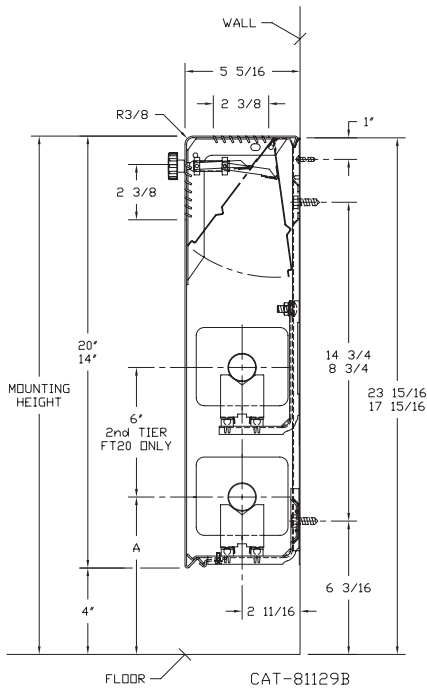

ELEMENT TUBE SIZE	ELEMENT FIN SIZE HEIGHT x WIDTH	CRADLE	A
3/4" COPPER	3 5/8 x 4 1/4	2	7"
3/4" COPPER	4 1/4 x 4 1/4	3A	7 3/8"

- JVB-FT 14
 JVB-FT 20

- JVB-FT 24
 JVB-FT 30
 JVB-FT 36

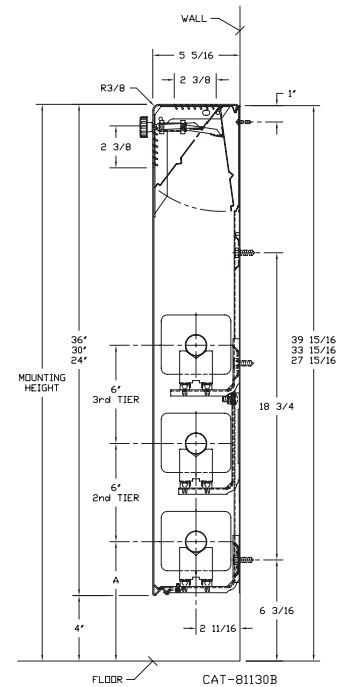

260 North Elm St., Westfield, MA 01085
 (413) 564-5535 Fax: (413) 562-8437
 www.sterlingheat.com

PROJECT: _____ DATE: _____
 LOCATION: _____
 ARCHITECT: _____
 ENGINEER: _____
 CONTRACTOR: _____
 PO NUMBER: _____



JVB-FT Style "FT" Front & Top Outlet

Copper/Aluminum Elements

ALL RATINGS ARE BASED ON 3 FPS WATER VELOCITY, 65°EAT

TUBE SIZE	CATALOG DESIGNATION	FIN SIZE HEIGHT X WIDTH	FIN PER FT.	FIN THICKNESS IN INCHES	ENCL DEPTH AND HEIGHT IN INCHES	TIERS AND CENTERS IN INCHES	MTG. HEIGHT IN INCHES	STEAM 215°F FACTOR	HOT WATER (AVG.)										
									200°F	190°F	180°F	170°F	160°F	150°F	140°F	130°F	120°F	110°F	100°F
									0.86	0.78	0.69	0.61	0.53	0.45	.40	.33	.26	.20	.15
3/4"	C3/4-433	3-5/8" x 4-1/4"	32	.020	14B	1	18	1440	1240	1120	990	880	760	650	580	480	370	290	220
					20B	1	24	1520	1310	1190	1050	930	810	680	610	500	400	300	230
					20B	2-6 CL	24	2150	1850	1680	1480	1310	1140	970	860	710	560	430	320
					24B	1	28	1560	1340	1220	1080	950	830	700	620	510	410	310	230
					24B	2-6 CL	28	2230	1920	1740	1540	1360	1180	1000	890	740	580	450	330
					24B	3-6 CL	28	2560	2200	2000	1770	1560	1360	1150	1020	840	670	510	380
					30B	1	34	1640	1410	1280	1130	1000	870	740	660	540	430	330	250
					30B	2-6 CL	34	2310	1990	1800	1590	1410	1220	1040	920	760	600	460	350
					30B	3-6 CL	34	2660	2290	2070	1840	1620	1410	1200	1060	880	690	530	400
					36B	1	40	1720	1480	1340	1190	1050	910	770	690	570	450	340	260
					36B	2-6 CL	40	2390	2060	1860	1650	1460	1270	1080	960	790	620	480	360
					36B	3-6 CL	40	2750	2370	2150	1900	1680	1460	1240	1100	910	720	550	410
					3/4"	C3/4-434	3-5/8" x 4-1/4"	40	.020	14B	1	18	1620	1390	1260	1120	990	860	730
20B	1	24	1700	1460						1330	1170	1040	900	770	680	560	440	340	260
20B	2-6 CL	24	2410	2070						1880	1660	1470	1280	1080	960	800	630	480	360
24B	1	28	1740	1500						1360	1200	1060	920	780	700	570	450	350	260
24B	2-6 CL	28	2490	2140						1940	1720	1520	1320	1120	1000	820	650	500	370
24B	3-6 CL	28	2840	2440						2220	1960	1730	1510	1280	1140	940	740	570	430
30B	1	34	1820	1570						1420	1260	1110	960	820	730	600	470	360	270
30B	2-6 CL	34	2570	2210						2000	1770	1570	1360	1160	1030	850	670	510	390
30B	3-6 CL	34	2930	2520						2290	2020	1790	1550	1320	1170	970	760	590	440
36B	1	40	1900	1630						1480	1310	1160	1010	860	760	630	490	380	290
36B	2-6 CL	40	2650	2280						2070	1830	1620	1400	1190	1060	870	690	530	400
36B	3-6 CL	40	3020	2600						2360	2080	1840	1600	1360	1210	1000	790	600	450
3/4"	C3/4-435	3-5/8" x 4-1/4"	50	.020						14B	1	18	1770	1520	1380	1220	1080	940	800
					20B	1	24	1920	1650	1500	1320	1170	1020	860	770	630	500	380	290
					20B	2-6 CL	24	2680	2300	2090	1850	1630	1420	1210	1070	880	700	540	400
					24B	1	28	1990	1710	1550	1370	1210	1050	900	800	660	520	400	300
					24B	2-6 CL	28	2860	2460	2230	1970	1740	1520	1290	1140	940	740	570	430
					24B	3-6 CL	28	3230	2780	2520	2230	1970	1710	1450	1290	1070	840	650	480
					30B	1	34	2110	1810	1650	1460	1290	1120	950	840	700	550	420	320
					30B	2-6 CL	34	3010	2590	2350	2080	1840	1600	1350	1200	990	780	600	450
					30B	3-6 CL	34	3400	2920	2650	2350	2070	1800	1530	1360	1120	880	680	510
					36B	1	40	2260	1940	1760	1560	1380	1200	1020	900	750	590	450	340
					36B	2-6 CL	40	3160	2720	2460	2180	1930	1670	1420	1260	1040	820	630	470
					36B	3-6 CL	40	3570	3070	2780	2460	2180	1890	1610	1430	1180	930	710	540
					3/4"	C3/4-43	4-1/4" SQ.	32	.020	14B	1	18	1590	1370	1240	1100	970	840	720
20B	1	24	1630	1400						1270	1120	990	860	730	650	540	420	330	240
20B	2-6 CL	24	2430	2090						1900	1680	1480	1290	1090	970	800	630	490	360
24B	1	28	1660	1430						1290	1150	1010	880	750	660	550	430	330	250
24B	2-6 CL	28	2480	2130						1930	1710	1510	1310	1120	990	820	640	500	370
24B	3-6 CL	28	2850	2450						2220	1970	1740	1510	1280	1140	940	740	570	430
30B	1	34	1720	1480						1340	1190	1050	910	770	690	570	450	340	260
30B	2-6 CL	34	2540	2180						1980	1750	1550	1350	1140	1020	840	660	510	380
30B	3-6 CL	34	2920	2510						2280	2010	1780	1550	1310	1170	960	760	580	440
36B	1	40	1780	1530						1390	1230	1090	940	800	710	590	460	360	270
36B	2-6 CL	40	2600	2240						2030	1790	1590	1380	1170	1040	860	680	520	390
36B	3-6 CL	40	2990	2570						2330	2060	1820	1580	1350	1200	990	780	600	450
3/4"	C3/4-44	4-1/4" SQ.	40	.020						14B	1	18	1850	1590	1440	1280	1130	980	830
					20B	1	24	2080	1790	1620	1440	1270	1100	940	830	690	540	420	310
					20B	2-6 CL	24	2500	2150	1950	1720	1530	1330	1130	1000	830	650	500	380
					24B	1	28	2120	1820	1650	1460	1290	1120	950	850	700	550	420	320
					24B	2-6 CL	28	2650	2280	2070	1830	1620	1400	1190	1060	870	690	530	400
					24B	3-6 CL	28	3020	2600	2360	2080	1840	1600	1360	1210	1000	790	600	450
					30B	1	34	2250	1940	1760	1550	1370	1190	1010	900	740	590	450	340
					30B	2-6 CL	34	2800	2410	2180	1930	1710	1480	1260	1120	920	730	560	420
					30B	3-6 CL	34	3190	2740	2490	2200	1950	1690	1440	1280	1050	830	640	480
					36B	1	40	2320	2000	1810	1600	1420	1230	1040	930	770	600	460	350
					36B	2-6 CL	40	2900	2490	2260	2000	1770	1540	1310	1160	960	750	580	440
					36B	3-6 CL	40	3310	2850	2580	2280	2020	1750	1490	1320	1090	860	660	500
					3/4"	C3/4-45	4-1/4" SQ.	50	.020	14B	1	18	1870	1610	1460	1290	1140	990	840
20B	1	24	2090	1800						1630	1440	1270	1110	940	840	690	540	420	310
20B	2-6 CL	24	2520	2170						1970	1740	1540	1340	1130	1010	830	660	500	380
24B	1	28	2190	1880						1710	1510	1340	1160	990	880	720	570	440	330
24B	2-6 CL	28	2700	2320						2110	1860	1650	1430	1220	1080	890	700	540	410
24B	3-6 CL	28	3050	2620						2380	2100	1860	1620	1370	1220	1010	790	610	460
30B	1	34	2340	2010						1830	1610	1430	1240	1050	940	770	610	470	350
30B	2-6 CL	34	2850	2450						2220	1970	1740	1510	1280	1140	940	740	570	430
30B	3-6 CL	34	3220	2770						2510	2220	1960	1710	1450	1290	1060	840	640	480
36B	1	40	2490	2140						1940	1720	1520	1320	1120	1000	820	650	500	370
36B	2-6 CL	40	3000	2580						2340	2070	1830	1590	1350	1200	990	780	600	450
36B	3-6 CL	40	3390	2920						2640	2340	2070	1800	1530	1360	1120	880	680	510

Design Data

Correction Factor Chart for Non-Standard Mounting Heights

MOUNTING HEIGHT (Inches)	ENCLOSURE STYLE						
	BARE FIN ALL SIZES	FRONT OUTLET	FT (FRONT & TOP)		SLOPE		
			3 ¹ / ₄ " FINS	4 ¹ / ₄ " FINS	2 ³ / ₄ " FINS	3 ¹ / ₄ " FINS	4 ¹ / ₄ " FINS
40 or more	1.000	1.000	1.000	1.000	1.000	1.000	1.000
38	1.000	1.000	1.000	1.000	1.000	1.000	1.003
36	1.000	1.004	1.005	1.005	1.006	1.007	1.009
34	1.010	1.014	1.011	1.010	1.012	1.013	1.016
32	1.020	1.024	1.017	1.015	1.019	1.020	1.025
30	1.030	1.039	1.029	1.024	1.031	1.033	1.039
29	1.040	1.049	1.035	1.029	1.038	1.040	1.045
28	1.050	1.059	1.041	1.034	1.045	1.047	1.052
27	1.060	1.069	1.046	1.039	1.051	1.053	1.059
26	1.070	1.079	1.052	1.044	1.058	1.060	1.065
25	1.080	1.089	1.058	1.049	1.065	1.067	1.072
24	1.090	1.099	1.064	1.054	1.071	1.073	1.079
23	1.100	1.109	1.070	1.059	1.078	1.080	1.085
22	1.110	1.119	1.076	1.064	1.085	1.087	1.092
21	1.120	1.129	1.082	1.069	1.091	1.093	1.099
20	1.130	1.139	1.088	1.074	1.098	1.100	1.100
19	1.140	1.149	1.089	1.075	1.100	1.100	1.100
18 or less	1.150	1.150	1.089	1.075	1.100	1.100	1.100

TOP OUTLET "T" IS NOT AFFECTED.

The AHRI Ratings cataloged include the factor shown for the recommended mounting height.

If the unit is to be installed at a different height than that recommended, the AHRI Rating (except for Top Outlet) must be adjusted as follows: AHRI Rating multiplied by

Factor from Table Above
for actual mounting height

Factor from Table Above
for recommended mounting height

EXAMPLE: Corrected steam rating for
1 row C145 element in JVBF14 (14"
high enclosures) mounted 30" above
floor in lieu of the 18" recommended.

FORMULA:

Catalog Rating x $\frac{\text{Factor at 30" Height}}{\text{Factor at 18" Height}}$

SOLUTION: 1950 x $\frac{1.039}{1.150}$ = 1760 BTU/Hr.

DYNAMIC FORMULAS

BTU = GPM x 500 x TD

$$\text{GPM} = \left(\frac{\text{BTU}}{500} \right) \div \text{TD}$$

$$\text{TD} = \left(\frac{\text{BTU}}{500} \right) \div \text{GPM}$$

Design Data

COMMERCIAL FINNED TUBE RATING CORRECTION CHARTS

CATALOG FINNED TUBE RATINGS ARE BASED UPON THE FOLLOWING CONDITIONS:

- 215°F AVERAGE WATER OR STEAM TEMPERATURE
- 65°F ENTERING AIR TEMPERATURE
- 3 FEET PER SECOND WATER FLOW RATE
- CATALOG MOUNTING HEIGHT

USE THE FOLLOWING CALCULATION WITH CORRECTION FACTORS FOR JOB CONDITIONS TO DETERMINE CORRECTED RATING:

$$\text{CORRECTED RATING} = (\text{215°F CATALOG RATING}) \times \left(\frac{\text{CORRECTION FACTOR FOR STEAM OR WATER AND AVERAGE AIR TEMP.}}{\text{CORRECTION FACTOR FOR MOUNTING HTG.-SEE CATALOG RATING}} \right) \times \left(\frac{\text{CORRECTION FACTOR FOR FLOW RATE}}{\text{CORRECTION FACTOR FOR MOUNTING HTG.-SEE CATALOG RATING}} \right)$$

USE THE FOLLOWING CHARTS TO SELECT CORRECTION FACTORS

CHART/WATER VEL./CORR. FACTOR / PRESS. DROP/TOTAL BTU.

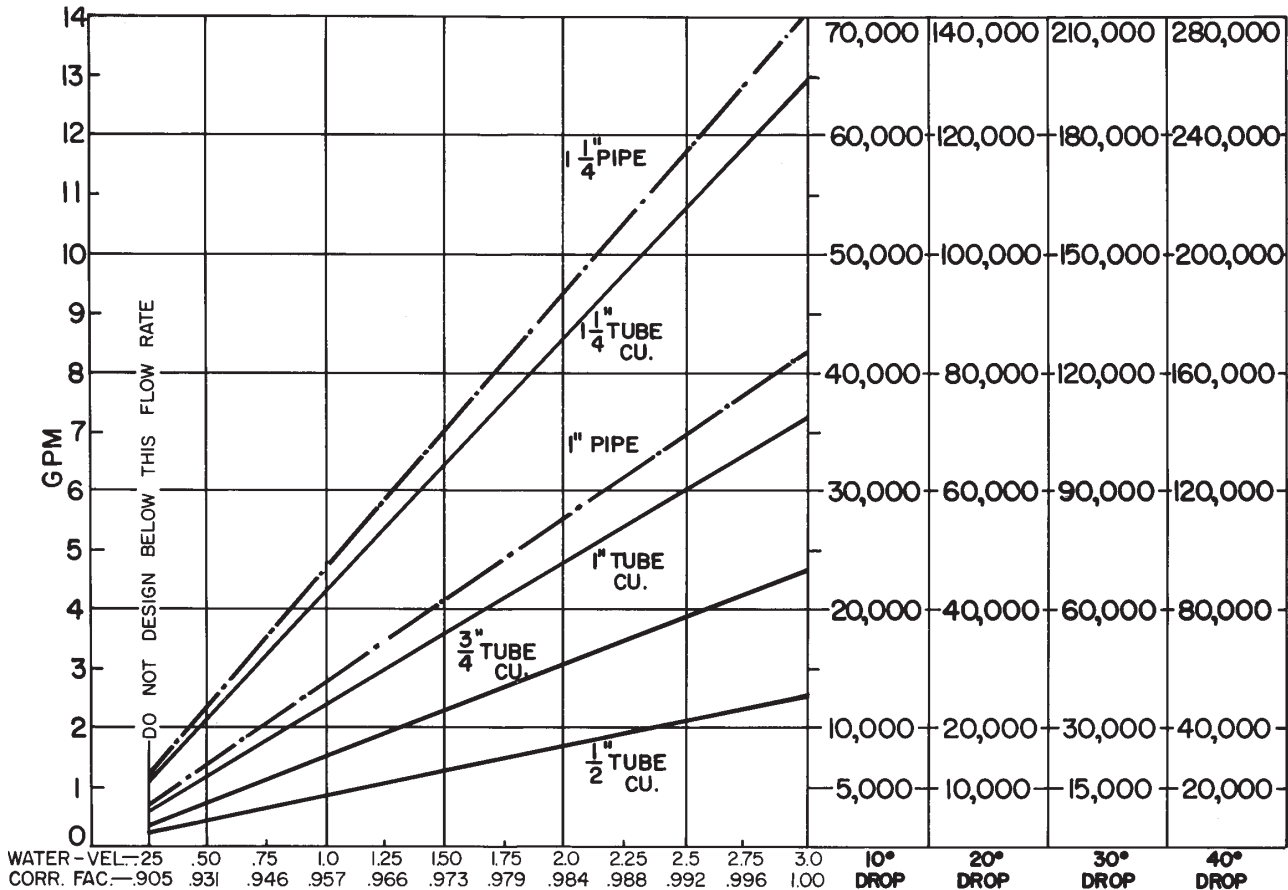

1/2" COP. ALUM.	.180	.233	.333	.533	.916											
3/4" COP. ALUM.	.5		1.5		3.16	5.4	6.25									
1" COP. ALUM.	.233	.41	.83	1.45	2.16	2.83	3.66									
1" PIPE		.37	.79	1.3	2.00	2.70	3.70	4.80								
1 1/4" COP. ALUM.	.16	.33	.55	.79	1.08	1.33	1.8	2.25	2.26	2.91	3.3					
1 1/4" PIPE	.09	.18	.31	.5	.70	1.0	1.1	1.3	1.6	1.8	2.58	2.3	3.3			

PRESSURE DROP PER 100 LINEAR FT., IN FEET OF HEAD

Design Data

INLET AIR CORRECTION FACTOR

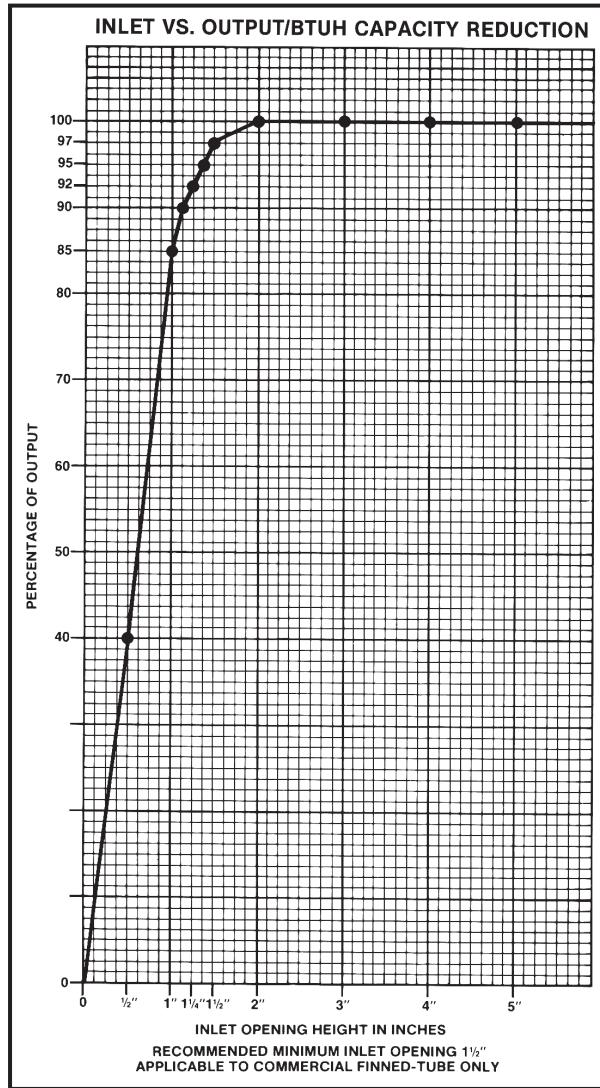

GUARANTEED WORKING PRESSURES

- 1" IPS — 780 AT TEMPERATURES UP TO 650°F.
- 1 1/4" IPS — 660 AT TEMPERATURES UP TO 650°F.
- 2" IPS — 405 AT TEMPERATURES UP TO 650°F.
- 1 1/4" CU — 194 AT TEMPERATURES UP TO 300°F.
- 1" CU — 204 AT TEMPERATURES UP TO 300°F.
- 3/4" CU — 218 PSI AT TEMPERATURES UP TO 300°F.

MAXIMUM PRESSURES AT OTHER TEMPERATURES ARE AVAILABLE UPON REQUEST.

RATE OF PITCH FOR STEAM 1/2" DROP OVER 20 FT. RUN.

PIPE WATER CAPACITIES AND QUANTITIES CIRCULATED AT VELOCITY OF 3* FEET PER SECOND			
Pipe Size	Gals. Per Linear Ft.	Gals./Min. @ 3' Sec. Vel.*	Lbs./Hr. @ 3' Sec. Vel.*
1/2"	.016	2.88	1440
3/4"	.023	4.14	2070
1"	.040	7.20	3600
1 1/4"	.063	11.34	5660
1 1/2"	.102	18.36	9160
2"	.170	30.60	15300
2 1/2"	.275	49.50	24850
3"	.390	70.20	35000

*3 Ft./Sec. Velocity is Basic for Hot Water Rating Factors Shown on this Page.

$$\text{VELOCITY FT./SEC.} = \frac{\text{LBS. PER HOUR}}{(\text{GALS. PER FT.}) (3600) (8.3)}$$

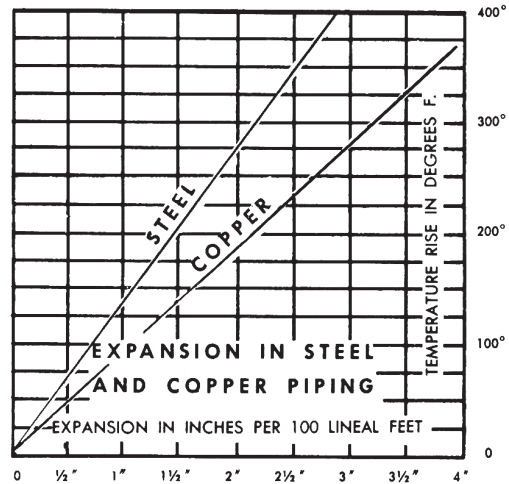

GLYCOL CORRECTION FACTORS

Fluid Temperature 200°F

% Solution	Ethylene Glycol	Propylene Glycol
20	.952	.988
30	.921	.968
40	.888	.943
50	.852	.912

Fluid Temperature 180°F

% Solution	Ethylene Glycol	Propylene Glycol
20	.946	.982
30	.913	.961
40	.879	.934
50	.842	.902

Fluid Temperature 140°F

% Solution	Ethylene Glycol	Propylene Glycol
20	.934	.97
30	.898	.946
40	.861	.916
50	.821	.881

ALTITUDE FACTORS

Approximate factors for convective heat value at varying altitudes

Altitude	Ferrous Units	Copper Alum. Units
Sea Level	1.000	1.000
1,000 ft.	.984	.969
2,000 ft.	.968	.938
3,000 ft.	.952	.908
4,000 ft.	.936	.878
5,000 ft.	.920	.850
6,000 ft.	.904	.822
7,000 ft.	.889	.795
8,000 ft.	.874	.768
9,000 ft.	.859	.743
10,000 ft.	.844	.718
15,000 ft.	.771	.603
20,000 ft.	.703	.502

Design Data

CORRECTION FACTORS FOR STEAM PRESSURES AND AIR TEMPERATURES OTHER THAN STANDARD

STEAM		ENTERING AIR TEMPERATURE, °F														
Pressure		Temp.			STD											
Gauge	Abs. Psi	°F	45	55	65	70	75	80	85	90	100	110	120	130	140	150
(Vac) 15" Hg	7.32	178.9	0.90	0.80	0.70	0.65	0.60	0.56	0.51	0.45	0.39	0.32	0.25	0.18	0.13	0.08
(Vac) 10"	9.78	192.2	1.02	0.91	0.81	0.76	0.71	0.66	0.62	0.55	0.48	0.40	0.33	0.26	0.20	0.14
(Vac) 5"	12.25	202.9	1.11	1.00	0.90	0.85	0.79	0.75	0.70	0.63	0.56	0.48	0.40	0.33	0.27	0.20
(Vac) 0 Psi	14.696	212.0	1.19	1.09	0.97	0.92	0.87	0.82	0.77	0.70	0.63	0.54	0.46	0.38	0.31	0.25
▶ .899	15.595	215.0	1.22	1.11	1.00	0.95	0.90	0.84	0.80	0.75	0.65	0.57	0.48	0.40	0.33	0.26
5	19.70	227.1	1.34	1.22	1.11	1.05	1.00	0.95	0.90	0.81	0.75	0.66	0.57	0.49	0.41	0.34
10	24.70	239.4	1.45	1.33	1.22	1.17	1.11	1.05	1.00	0.91	0.85	0.75	0.66	0.58	0.50	0.42
15	29.70	249.8	1.55	1.43	1.31	1.26	1.20	1.14	1.09	1.00	0.94	0.84	0.75	0.66	0.57	0.49
20	34.70	258.8	1.63	1.52	1.40	1.33	1.28	1.23	1.17	1.07	1.02	0.92	0.82	0.73	0.64	0.55
25	39.70	266.8	1.71	1.59	1.47	1.41	1.36	1.30	1.25	1.15	1.09	0.98	0.89	0.80	0.71	0.62
30	44.70	274.0	1.78	1.66	1.54	1.48	1.42	1.37	1.31	1.21	1.15	1.05	0.95	0.85	0.76	0.68
40	54.70	286.7	1.91	1.79	1.66	1.61	1.54	1.49	1.43	1.32	1.27	1.16	1.06	0.97	0.87	0.78
50	64.70	297.7	2.02	1.90	1.77	1.71	1.65	1.60	1.54	1.42	1.37	1.26	1.16	1.06	0.96	0.87
60	74.70	307.3	2.10	2.00	1.87	1.81	1.75	1.69	1.63	1.51	1.47	1.35	1.25	1.15	1.05	0.95
70	84.70	316.0	2.20	2.09	1.95	1.89	1.83	1.77	1.71	1.59	1.55	1.44	1.33	1.23	1.12	1.03
80	94.70	323.9	2.27	2.17	2.03	1.97	1.91	1.85	1.80	1.69	1.63	1.52	1.41	1.31	1.20	1.10
90	104.70	331.2	2.36	2.24	2.11	2.05	1.98	1.93	1.87	1.74	1.70	1.59	1.48	1.38	1.28	1.17
100	114.70	337.9	2.43	2.31	2.18	2.11	2.05	2.00	1.94	1.81	1.77	1.65	1.54	1.44	1.33	1.23
125	139.70	352.9	2.59	2.47	2.33	2.27	2.21	2.16	2.10	1.96	1.92	1.80	1.69	1.59	1.48	1.38
150	164.70	365.9	2.73	2.62	2.47	2.43	2.35	2.29	2.23	2.08	2.05	1.94	1.82	1.72	1.61	1.51
175	189.70	377.4	2.86	2.74	2.60	2.54	2.47	2.41	2.35	2.21	2.17	2.05	1.95	1.85	1.73	1.63
200	214.70	387.8	2.95	2.85	2.71	2.63	2.58	2.52	2.47	2.31	2.29	2.17	2.06	1.96	1.84	1.75

From Keenan and Keyes — Linear Interpolation.

Note: Gauge pressure should be corrected for altitude.

CORRECTION FACTORS FOR WATER TEMPERATURES AND AIR TEMPERATURES OTHER THAN STANDARD

AVERAGE WATER TEMP. °F	ENTERING AIR TEMPERATURE, °F															
	45	55	STD	65	70	75	80	85	90	95	100	110	120	130	140	150
90	.19	.13	.11	.06												
100	.25	.19	.15	.11	.08	.06										
110	.31	.25	.20	.16	.13	.11	.08	.06								
120	.38	.31	.26	.21	.19	.16	.13	.11	.08	.06						
130	.45	.38	.33	.28	.25	.21	.19	.16	.13	.11	.06					
140	.53	.45	.40	.34	.31	.28	.25	.21	.19	.16	.11	.06				
150	.61	.53	.45	.41	.38	.34	.31	.28	.25	.21	.16	.11	.06			
160	.69	.61	.53	.49	.45	.41	.38	.34	.31	.28	.21	.16	.11	.06		
170	.77	.69	.61	.57	.53	.49	.45	.41	.38	.34	.28	.21	.16	.11	.06	
180	.86	.77	.69	.65	.61	.57	.53	.49	.45	.41	.34	.28	.21	.16	.11	.06
190	.95	.86	.78	.73	.69	.65	.61	.57	.53	.49	.41	.34	.28	.21	.16	.11
200	1.05	.95	.86	.82	.77	.73	.69	.65	.61	.57	.49	.41	.34	.28	.21	.16
210	1.14	1.05	.95	.91	.86	.82	.77	.73	.69	.65	.57	.49	.41	.34	.28	.21
▶ 215 (STD.)	1.19	1.09	1.00	.95	.91	.86	.82	.77	.73	.69	.61	.53	.45	.38	.31	.25
220	1.24	1.14	1.05	1.00	.95	.91	.86	.82	.77	.73	.65	.57	.49	.41	.34	.28
230	1.34	1.24	1.14	1.09	1.05	1.00	.95	.91	.86	.82	.73	.65	.57	.49	.41	.34
240	1.44	1.34	1.25	1.19	1.14	1.09	1.05	1.00	.95	.91	.82	.73	.65	.57	.49	.41
250	1.55	1.44	1.34	1.29	1.24	1.19	1.14	1.09	1.05	1.00	.91	.82	.73	.65	.57	.49
260	1.66	1.55	1.44	1.39	1.34	1.29	1.24	1.19	1.14	1.09	1.00	.91	.82	.73	.65	.57
270	1.76	1.66	1.55	1.50	1.44	1.39	1.34	1.29	1.24	1.19	1.09	1.00	.91	.82	.73	.65
280	1.87	1.76	1.66	1.60	1.55	1.50	1.44	1.39	1.34	1.29	1.19	1.09	1.00	.91	.82	.73
290	1.99	1.87	1.76	1.71	1.66	1.60	1.55	1.50	1.44	1.39	1.29	1.19	1.09	1.00	.91	.82
300	2.10	1.99	1.87	1.82	1.76	1.71	1.66	1.60	1.55	1.50	1.39	1.29	1.19	1.09	1.00	.91

In the interest of product improvement, Sterling reserves the right to make changes without notice.