



**VERSA-LINE COMMERCIAL FINNED TUBE
DAMPER INSTALLATION GUIDES**

Style	Description	Type	Page
S	Slope Top	Knob	2
S	Slope Top	TR	3
SS	Double Slope or Inverted S	Knob	4
SS	Double Slope or Inverted S	TR	5
T	Top Outlet	Knob	6
T	Top Outlet	TR	7
F	Front Outlet	Knob	8
F	Front Outlet	TR	9
FT	Front & Top Outlet	Knob	10
FT	Front & Top Outlet	TR	11
RD	Rounded Outlet	Knob	12
RD	Rounded Outlet	TR	13
	Tamper Resistant Assy.	TR	14

NOTE: Damper Blades on all styles listed above are welded into place at the factory. The Damper Operator Assembly is to be field installed by the contractor.

Installing Knob Damper Operator

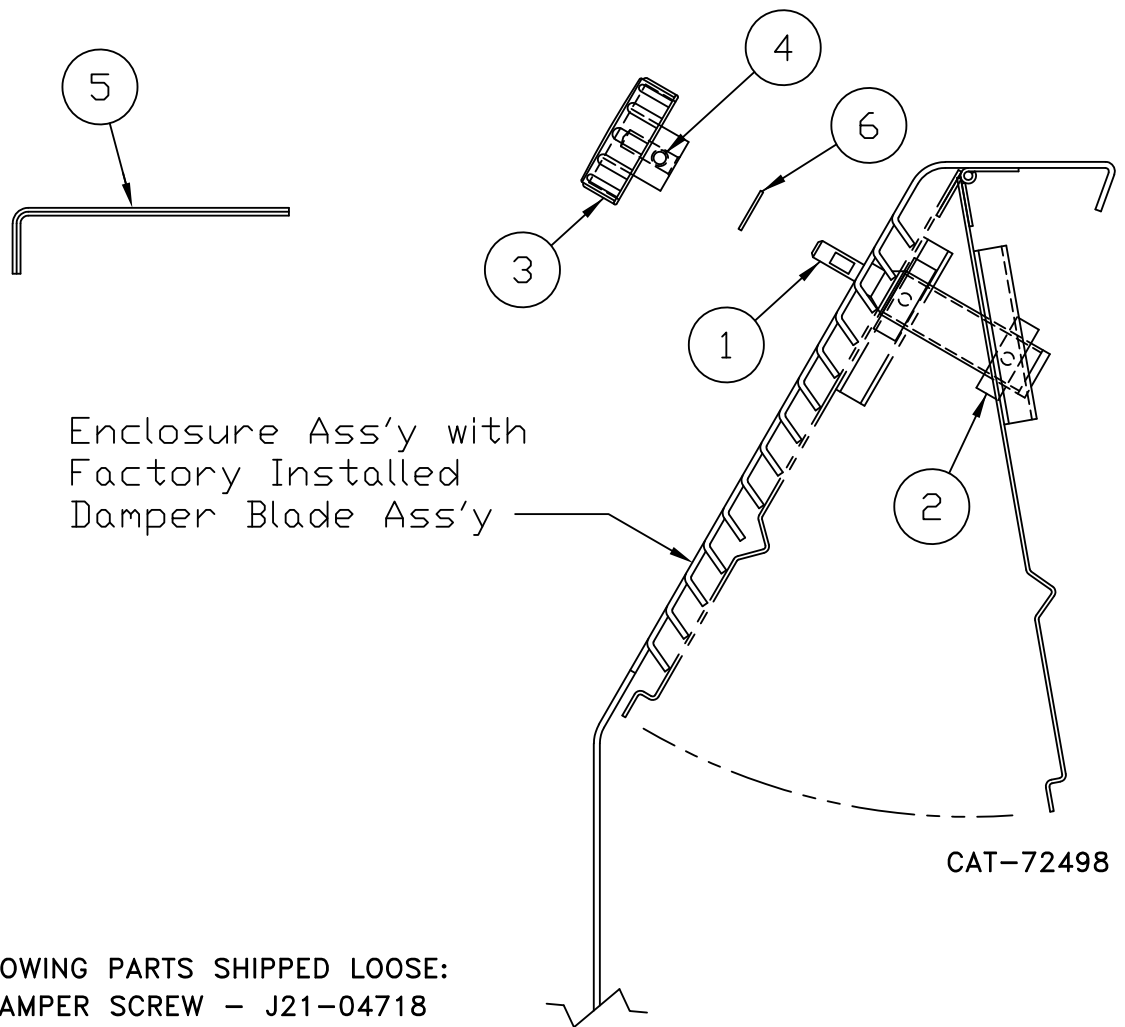

FOLLOWING PARTS SHIPPED LOOSE:

1. DAMPER SCREW - J21-04718
2. NUT ASS'Y - E06-02342
3. DAMPER KNOB - J37-04719
4. SET SCREW #8-32 x 5/64 - J21-05718
5. SOCKET WRENCH 5/64 - J24-02301
6. BRASS WASHER - J24-00322-010

INSTALLATION STEPS:

1. Place enclosure on bench or horses.
2. Screw damper screw (1) into nut ass'y (2), to limit of screw.
3. Insert nut ass'y (with screw) into blade so that nut pins are between guides and blade.
4. Insert screw shaft into enclosure hole. Place washer on shaft. Holding screw firmly against enclosure, place knob (3) on shaft and tighten set screw (4) against flat of shaft.

Installing Tamper Resistant Damper Operator

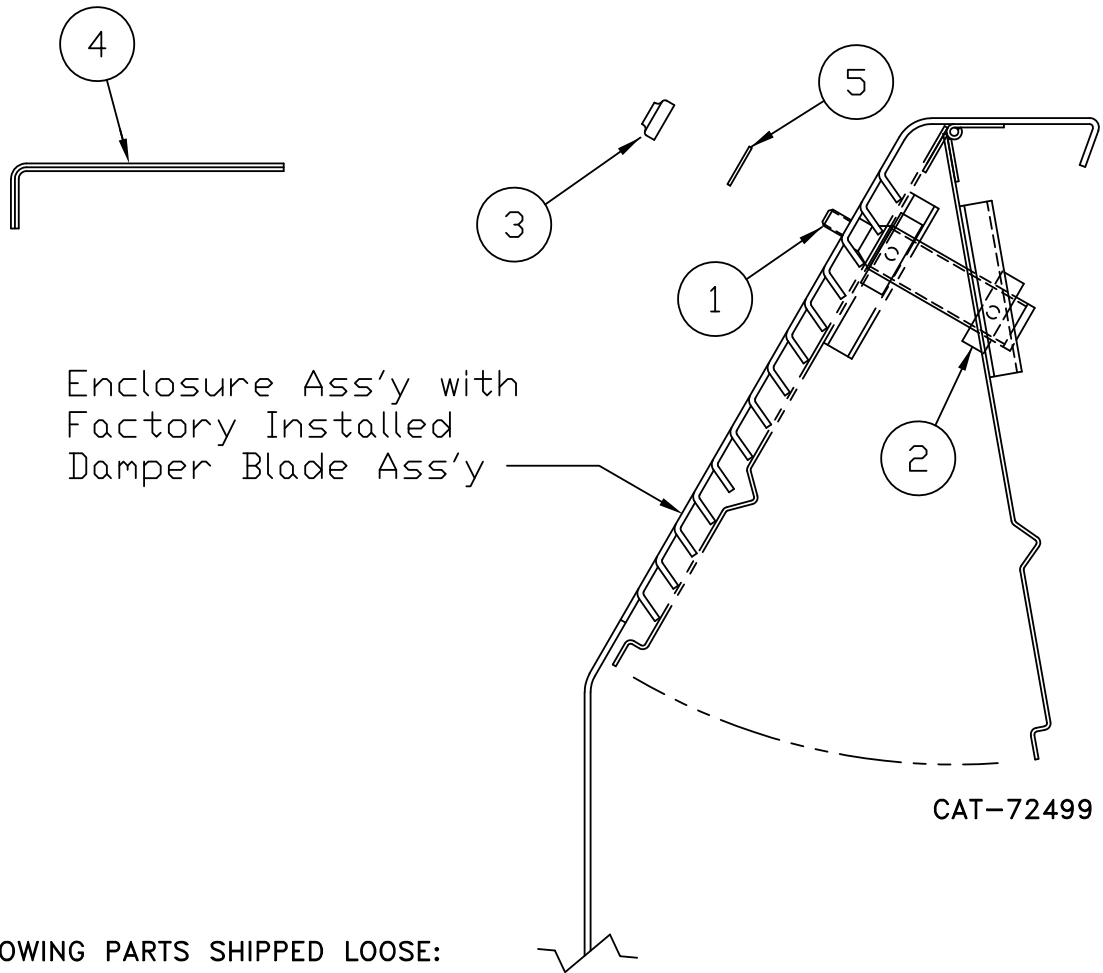

FOLLOWING PARTS SHIPPED LOOSE:

1. T-R DAMPER SCREW - J21-43099
2. NUT ASS'Y - E06-02342
3. T-R DAMPER NUT - J23-04914
4. SOCKET WRENCH 5/64 - J24-02301
5. BRASS WASHER - J24-00322-010

INSTALLATION STEPS:

1. Place enclosure on bench or horses.
2. Screw damper screw (1) into nut ass'y (2), to limit of screw.
3. Insert nut ass'y (with screw) into blade so that nut pins are between guides and blade.
4. Insert screw shaft into enclosure hole. Place washer on shaft. Holding screw firmly against enclosure, place t-r nut (3) on shaft and snug up t-r nut (3) with pliers.

Installing Knob Damper Operator

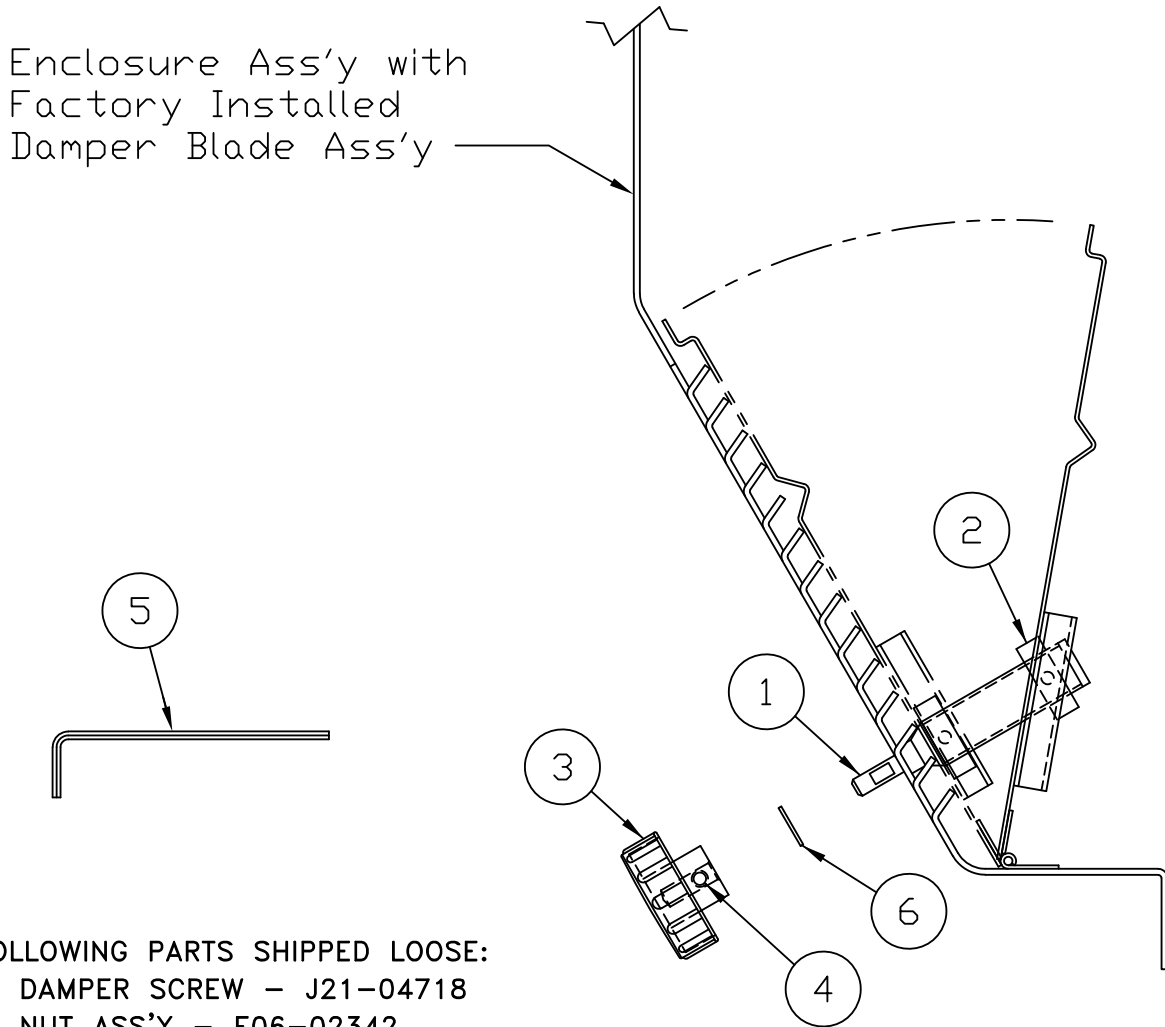

FOLLOWING PARTS SHIPPED LOOSE:

1. DAMPER SCREW - J21-04718
2. NUT ASS'Y - E06-02342
3. DAMPER KNOB - J37-04719
4. SET SCREW #8-32 x 5/64 - J21-05718
5. SOCKET WRENCH 5/64 - J24-02301
6. BRASS WASHER - J24-00322-010

INSTALLATION STEPS:

1. Place enclosure on bench or horses.
2. Screw damper screw (1) into nut ass'y (2), to limit of screw.
3. Insert nut ass'y (with screw) into blade so that nut pins are between guides and blade.
4. Insert screw shaft into enclosure hole. Place washer on shaft. Holding screw firmly against enclosure, place knob (3) on shaft and tighten set screw (4) against flat of shaft.

Installing Tamper Resistant Damper Operator

Enclosure Ass'y with
Factory Installed
Damper Blade Ass'y

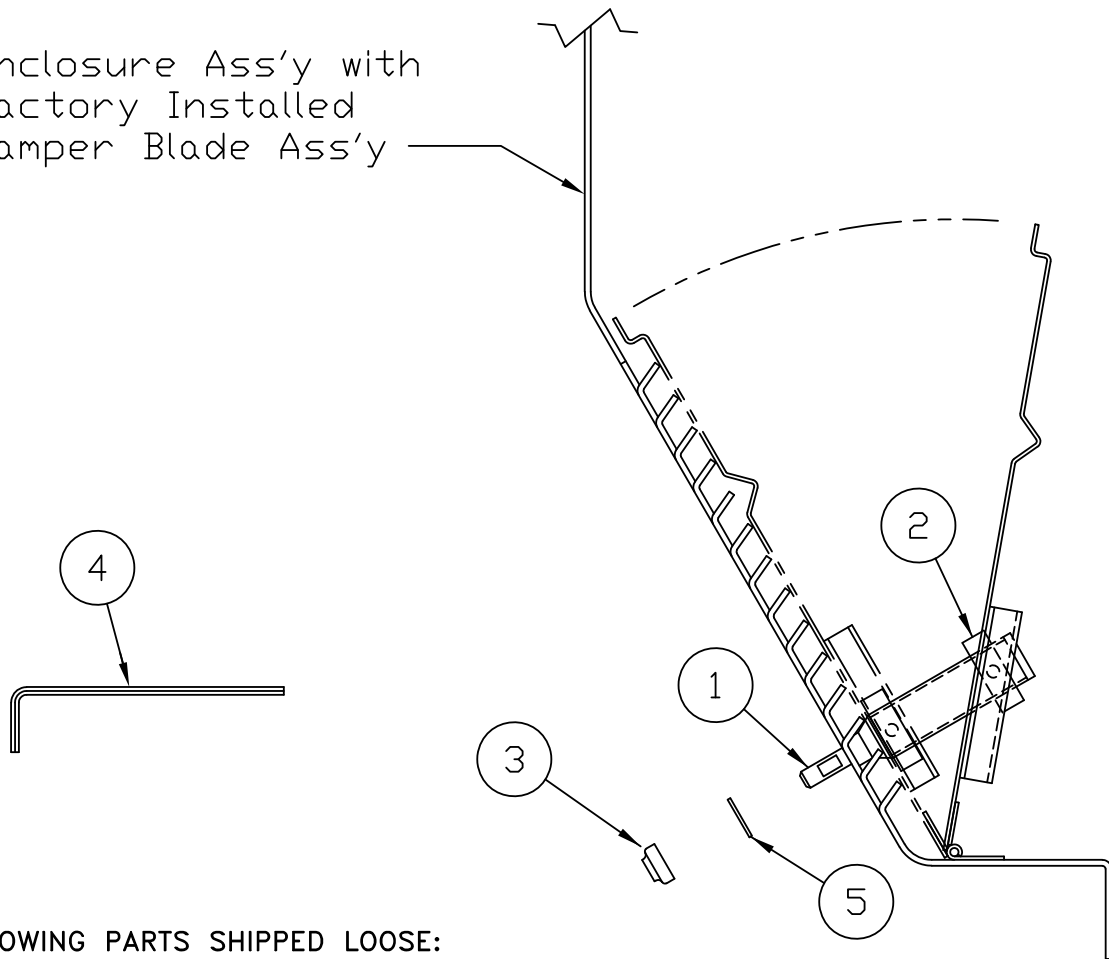

FOLLOWING PARTS SHIPPED LOOSE:

1. T-R DAMPER SCREW - J21-43099
2. NUT ASS'Y - E06-02342
3. T-R DAMPER NUT - J23-04914
4. SOCKET WRENCH 5/64 - J24-02301
5. BRASS WASHER - J24-00322-010

CAT-72501

INSTALLATION STEPS:

1. Place enclosure on bench or horses.
2. Screw damper screw (1) into nut ass'y (2), to limit of screw.
3. Insert nut ass'y (with screw) into blade so that nut pins are between guides and blade.
4. Insert screw shaft into enclosure hole. Place washer on shaft. Holding screw firmly against enclosure, place t-r nut (3) on shaft and snug up t-r nut (3) with pliers.

Installing Knob Damper Operator

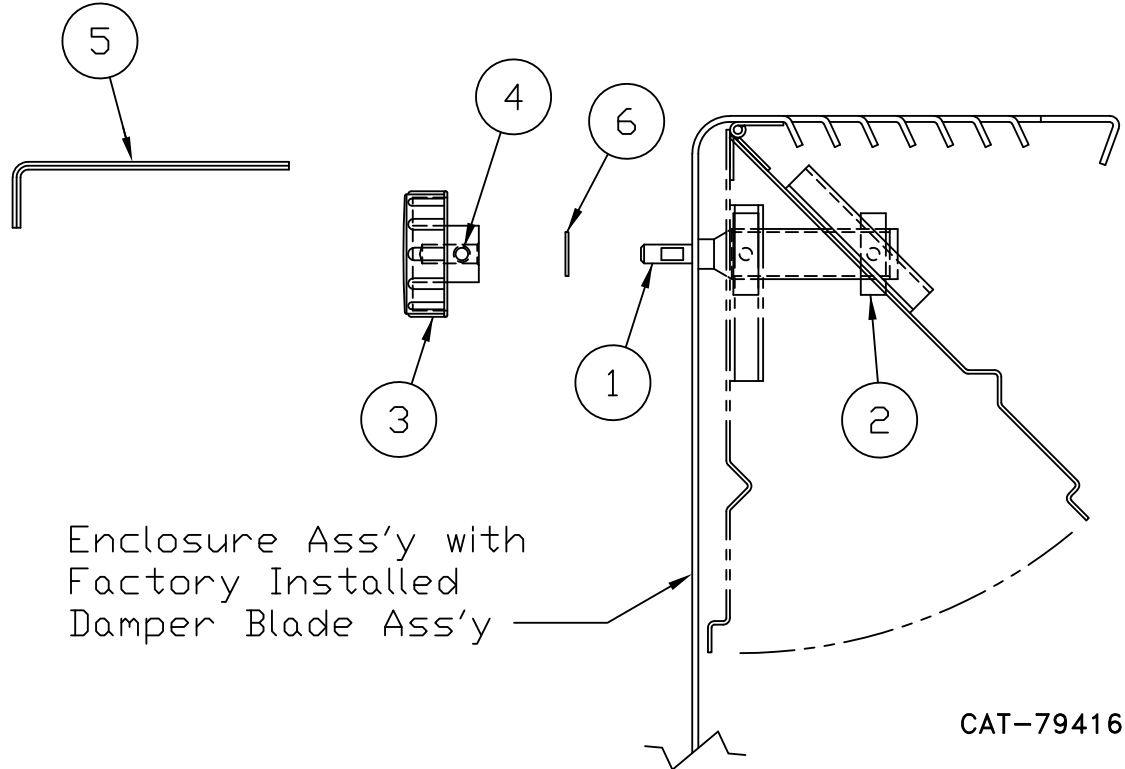

FOLLOWING PARTS SHIPPED LOOSE:

1. DAMPER SCREW - J21-04718
2. NUT ASS'Y - E06-02342
3. DAMPER KNOB - J37-04719
4. SET SCREW #8-32 x 5/64 - J21-05718
5. SOCKET WRENCH 5/64 - J24-02301
6. BRASS WASHER - J24-00322-010

INSTALLATION STEPS:

1. Place enclosure on bench or horses.
2. Screw damper screw (1) into nut ass'y (2), to limit of screw.
3. Insert nut ass'y (with screw) into blade so that nut pins are between guides and blade.
4. Insert screw shaft into enclosure hole. Place washer on shaft. Holding screw firmly against enclosure, place knob (3) on shaft and tighten set screw (4) against flat of shaft.

Installing Tamper Resistant Damper Operator

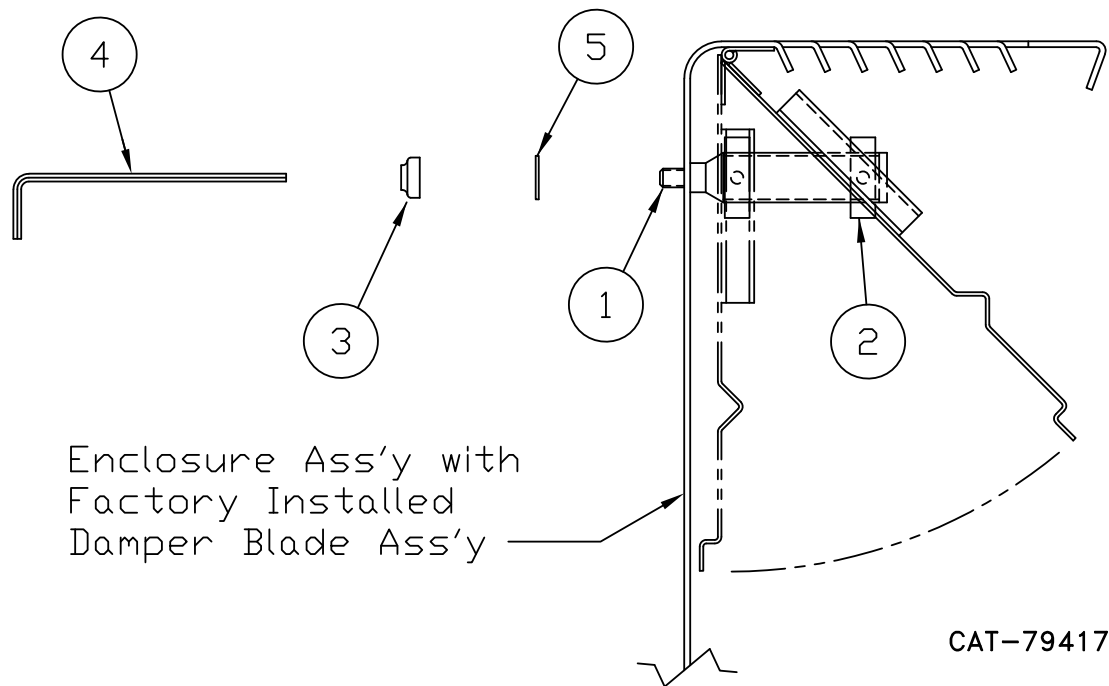

FOLLOWING PARTS SHIPPED LOOSE:

1. T-R DAMPER SCREW - J21-43099
2. NUT ASS'Y - E06-02342
3. T-R DAMPER NUT - J23-04914
4. SOCKET WRENCH 5/64 - J24-02301
5. BRASS WASHER - J24-00322-010

INSTALLATION STEPS:

1. Place enclosure on bench or horses.
2. Screw damper screw (1) into nut ass'y (2), to limit of screw.
3. Insert nut ass'y (with screw) into blade so that nut pins are between guides and blade.
4. Insert screw shaft into enclosure hole. Place washer on shaft. Holding screw firmly against enclosure, place t-r nut (3) on shaft and snug up t-r nut (3) with pliers.

Installing Knob Damper Operator

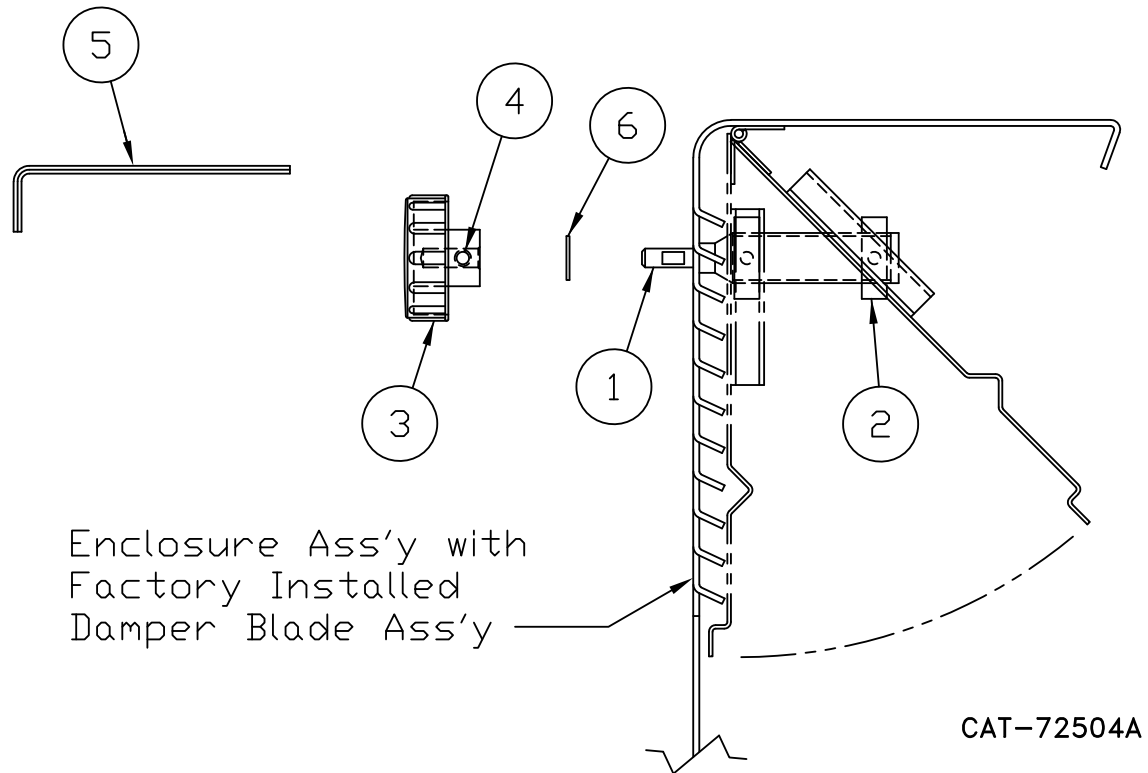

FOLLOWING PARTS SHIPPED LOOSE:

1. DAMPER SCREW - J21-04718
2. NUT ASS'Y - E06-02342
3. DAMPER KNOB - J37-04719
4. SET SCREW #8-32 x 5/64 - J21-05718
5. SOCKET WRENCH 5/64 - J24-02301
6. BRASS WASHER - J24-00322-010

INSTALLATION STEPS:

1. Place enclosure on bench or horses.
2. Screw damper screw (1) into nut ass'y (2), to limit of screw.
3. Insert nut ass'y (with screw) into blade so that nut pins are between guides and blade.
4. Insert screw shaft into enclosure hole. Place washer on shaft. Holding screw firmly against enclosure, place knob (3) on shaft and tighten set screw (4) against flat of shaft.

Installing Tamper Resistant Damper Operator

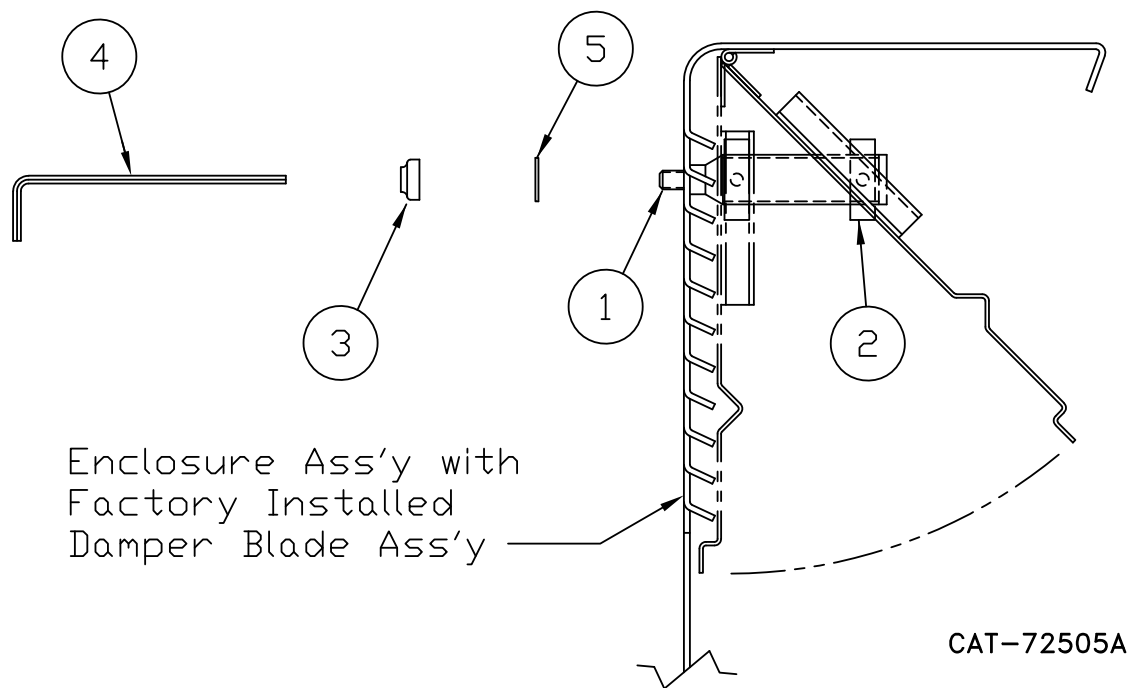

FOLLOWING PARTS SHIPPED LOOSE:

1. T-R DAMPER SCREW - J21-43099
2. NUT ASS'Y - E06-02342
3. T-R DAMPER NUT - J23-04914
4. SOCKET WRENCH 5/64 - J24-02301
5. BRASS WASHER - J24-00322-010

INSTALLATION STEPS:

1. Place enclosure on bench or horses.
2. Screw damper screw (1) into nut ass'y (2), to limit of screw.
3. Insert nut ass'y (with screw) into blade so that nut pins are between guides and blade.
4. Insert screw shaft into enclosure hole. Place washer on shaft. Holding screw firmly against enclosure, place t-r nut (3) on shaft and snug up t-r nut (3) with pliers.

Installing Knob Damper Operator

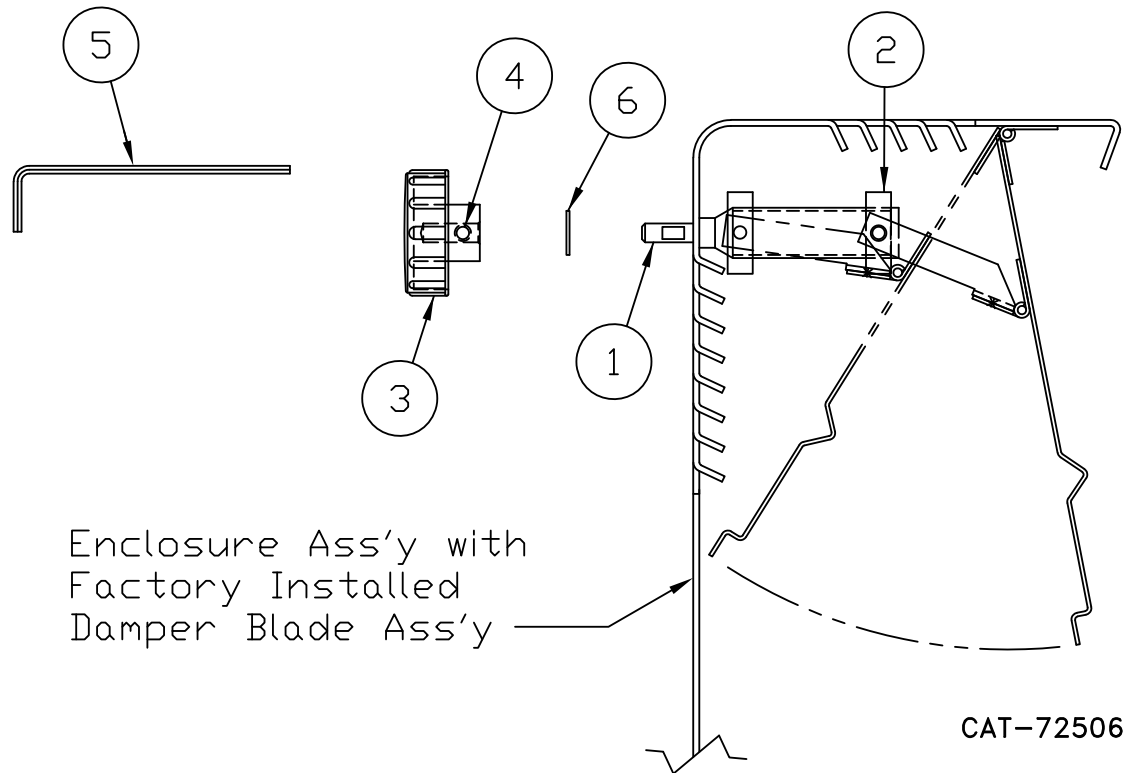

FOLLOWING PARTS SHIPPED LOOSE:

1. DAMPER SCREW - J21-04718
2. NUT ASS'Y - E06-02342
3. DAMPER KNOB - J37-04719
4. SET SCREW #8-32 x 5/64 - J21-05718
5. SOCKET WRENCH 5/64 - J24-02301
6. BRASS WASHER - J24-00322-010

INSTALLATION STEPS:

1. Place enclosure on bench or horses.
2. Screw damper screw (1) into nut ass'y (2), to limit of screw.
3. Insert nut ass'y (with screw) into blade so that nut pins are between guides and blade.
4. Insert screw shaft into enclosure hole. Place washer on shaft. Holding screw firmly against enclosure, place knob (3) on shaft and tighten set screw (4) against flat of shaft.

Installing Tamper Resistant Damper Operator

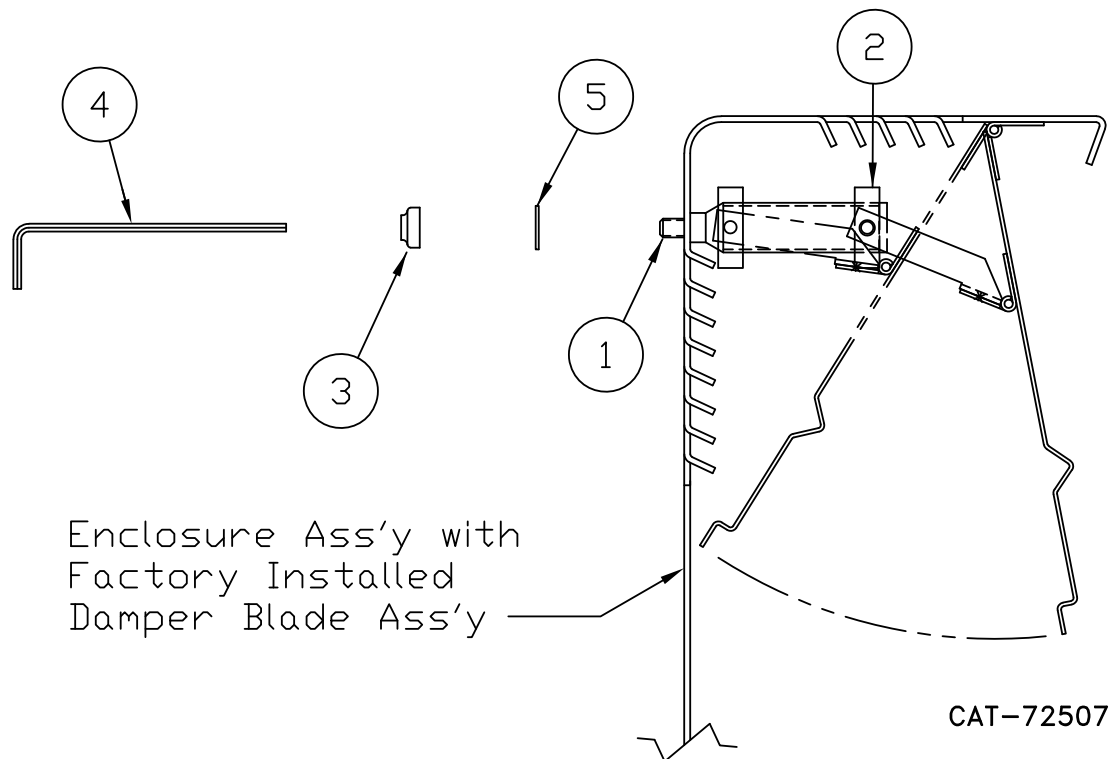

FOLLOWING PARTS SHIPPED LOOSE:

1. T-R DAMPER SCREW - J21-43099
2. NUT ASS'Y - E06-02342
3. T-R DAMPER NUT - J23-04914
4. SOCKET WRENCH 5/64 - J24-02301
5. BRASS WASHER - J24-00322-010

INSTALLATION STEPS:

1. Place enclosure on bench or horses.
2. Screw damper screw (1) into nut ass'y (2), to limit of screw.
3. Insert nut ass'y (with screw) into blade so that nut pins are between guides and blade.
4. Insert screw shaft into enclosure hole. Place washer on shaft. Holding screw firmly against enclosure, place t-r nut (3) on shaft and snug up t-r nut (3) with pliers.

Installing Knob Damper Operator

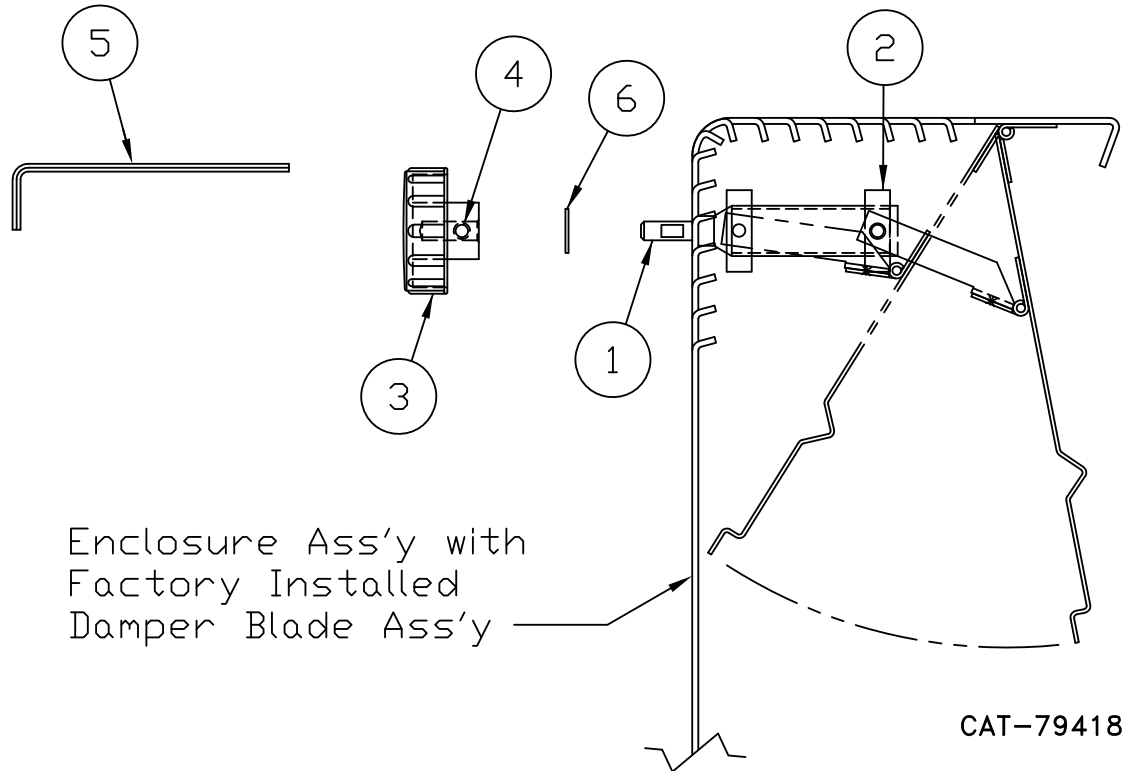

FOLLOWING PARTS SHIPPED LOOSE:

1. DAMPER SCREW - J21-04718
2. NUT ASS'Y - E06-02342
3. DAMPER KNOB - J37-04719
4. SET SCREW #8-32 x 5/64 - J21-05718
5. SOCKET WRENCH 5/64 - J24-02301
6. BRASS WASHER - J24-00322-010

INSTALLATION STEPS:

1. Place enclosure on bench or horses.
2. Screw damper screw (1) into nut ass'y (2), to limit of screw.
3. Insert nut ass'y (with screw) into blade so that nut pins are between guides and blade.
4. Insert screw shaft into enclosure hole. Place washer on shaft. Holding screw firmly against enclosure, place knob (3) on shaft and tighten set screw (4) against flat of shaft.

Installing Tamper Resistant Damper Operator

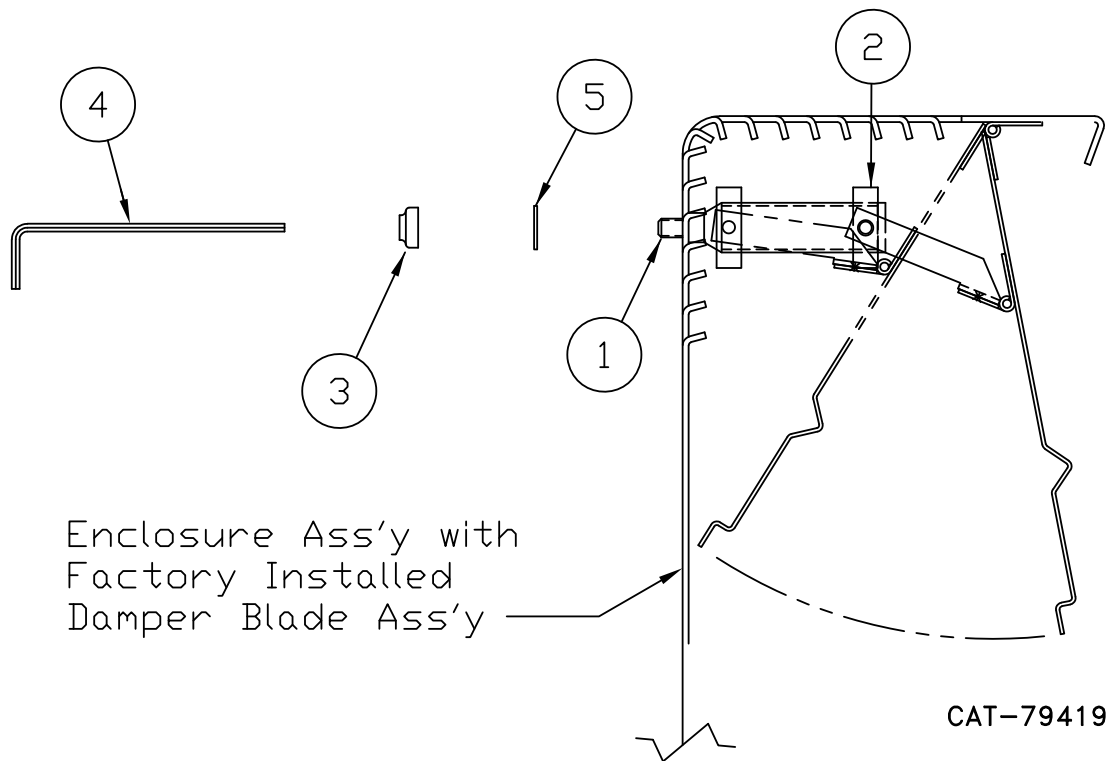

FOLLOWING PARTS SHIPPED LOOSE:

1. T-R DAMPER SCREW - J21-43099
2. NUT ASS'Y - E06-02342
3. T-R DAMPER NUT - J23-04914
4. SOCKET WRENCH 5/64 - J24-02301
5. BRASS WASHER - J24-00322-010

INSTALLATION STEPS:

1. Place enclosure on bench or horses.
2. Screw damper screw (1) into nut ass'y (2), to limit of screw.
3. Insert nut ass'y (with screw) into blade so that nut pins are between guides and blade.
4. Insert screw shaft into enclosure hole. Place washer on shaft. Holding screw firmly against enclosure, place t-r nut (3) on shaft and snug up t-r nut (3) with pliers.

INSTALLING DAMPER OPERATOR TAMPER RESISTANT DAMPER OPERATOR ASSEMBLY

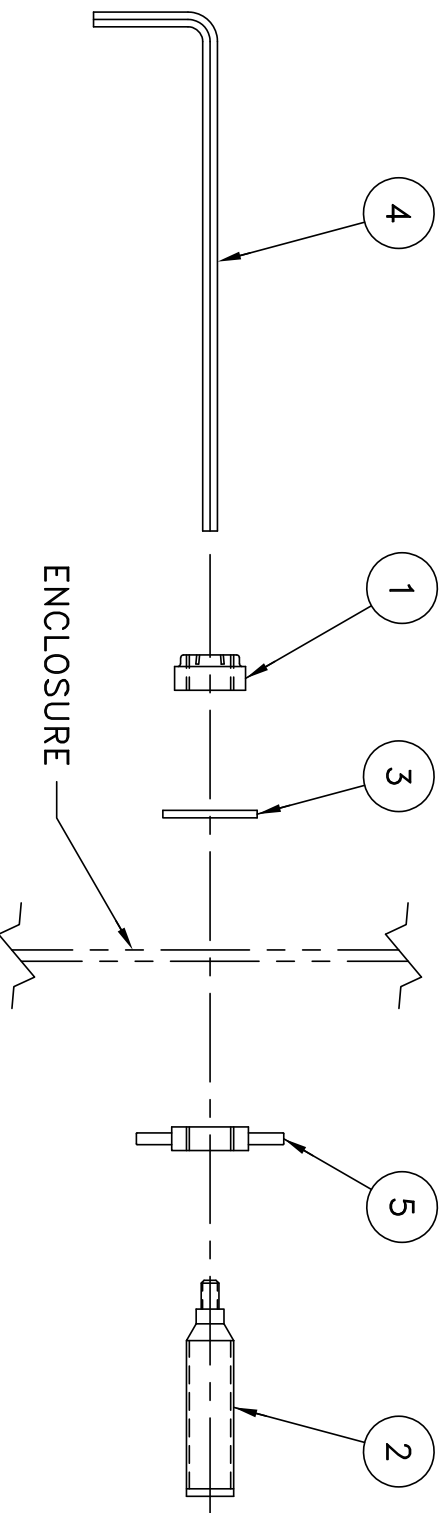

FOLLOWING PARTS SHIPPED LOOSE:

1. SPECIAL NUT – E09-04914
2. DAMPER SCREW – J21-43099
3. BRASS WASHER – J24-00322-010
4. SOCKET WRENCH 5/64 – J24-02301
5. NUT ASS'Y – E06-02342

INSTALLATION STEPS:

- (A) NUT ASSEMBLY (5) SHOULD BE SCREWED ABOUT 1/3 OF WAY ONTO SCREW (2).
- (B) STAND ENCLOSURE ON END AND OPEN DAMPER BLADE – SIMILAR TO FIGURE 2 (L-541).
- (C) INSERT SCREW AND NUT ASSEMBLY INTO DAMPER BLADE AS SHOWN IN FIGURE 2 (L-541). PINS IN NUT ASSEMBLY SHOULD BE BETWEEN GUIDE AND DAMPER BLADE WHEN PROPERLY INSTALLED.
- (D) WHILE CLOSING DAMPER BLADE, GUIDE SCREW SHAFT (2) INTO HOLE IN ENCLOSURE.
- (E) PLACE WASHER (3) ON SHAFT (2) PROTRUDING FROM FRONT OF ENCLOSURE.
- (F) THREAD SPECIAL NUT (1) ONTO SHAFT (2) PROTRUDING FROM FRONT OF ENCLOSURE AND SNUG UP NUT WITH PLIERS.
- (G) OPERATE DAMPER WITH SOCKET WRENCH (4), INSERTED INTO HEX SOCKET END OF SCREW (2) SHAFT.

CAT-569B