

Petite⁹



HIGH CAPACITY
BASEBOARD
RADIATION

RATINGS

MODEL	GPM	AVERAGE HOT WATER TEMPERATURE - BTU/HR./LIN. FT.						
		120°F	130°F	140°F	150°F	160°F	170°F	180°F
P9 3/4"	4	308	386	470	560	650	750	850
	1	292	366	445	530	620	710	800
P9 1"	4	297	373	454	540	630	730	820
	1	281	352	428	510	600	690	780

NOTES: All the ratings noted include a 15% addition for heating effect. These ratings are based on active length, which is total length less 4 1/2". Pressure drop for element with nominal 3/4" copper tube is 0.47 inches of water per linear foot at 1.0 GPM and .525 inches at 4.0 GPM. Pressure drop for element with nominal 1" copper tube is 0.13 inches of water per linear foot at 1.0 GPM and .145 inches at 4.0 GPM. The use of ratings at 4.0 GPM is limited to installations where the water flow rate through the baseboard unit is equal to or greater than 4.0 GPM. Where the water flow rate through the baseboard is not known, the rating of 1.0 GPM must be used.

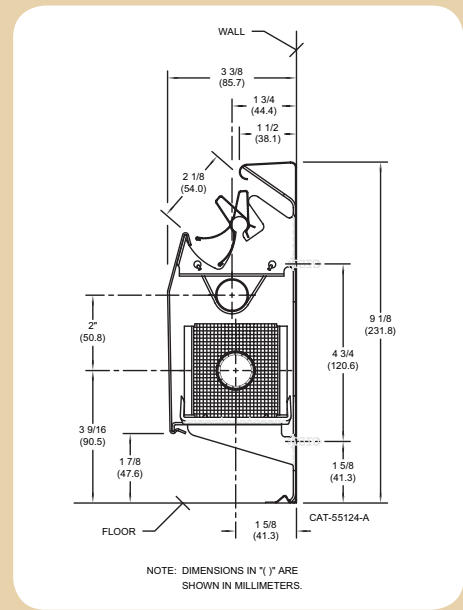

DESCRIPTION	CAT. NO.	PER CARTON
4" End Cap - Right Hand Hinged	P9-REC	12
4" End Cap - Left Hand Hinged	P9-LEC	12
3" Solid End Cap, Right	P9-3REC	10
3" Solid End Cap, Left	P9-3LEC	10
4" Solid End Cap, Right	P9-4REC	8
4" Solid End Cap, Left	P9-4LEC	8
90° Inside Corner	P9-IC	12
135° Inside Corner	P9-ICB	AS ORDERED
90° Outside Corner	P9-OC	10
135° Outside Corner	P9-OCB	AS ORDERED
2" Panel Joiner (3 pcs)	P9-PJ3	AS ORDERED
4" Wall Trim to Floor	P9-WJ	12
Element Slide Cradle	P9-ESC	AS ORDERED
Support Bracket + Nylon Cradle	P9-BR	AS ORDERED
Supply Tube Hanger (lower)	P9-STH	AS ORDERED
Return Tube Hanger (upper)	P9-RTH	AS ORDERED
14" Filler Piece Set	P9-FIS	AS ORDERED
Touch-Up Spray Paint	P9-TUP	6

ASSEMBLED BASEBOARD	ELEMENT SIZE	CARTON NO. SPECIFY
Model P9CU75 complete assembled units (single pack) include one length each of back panel, front panel, damper-louver and 3/4" heating element, 18 GA. front panel, plus required support brackets and element cradle expansion clips. Panel joiner included with 5', 6' & 8' lengths.	3/4" CU	P9CU75-8 P9CU75-7 P9CU75-6 P9CU75-5 P9CU75-4 P9CU75-3 P9CU75-2
Model P9CU100 complete assembled units (single pack) include one length each of back panel, front panel, damper-louver and 1" heating element, plus required support brackets and element cradle expansion clips. Panel joiner included with 5', 6', & 8' lengths.	1" CU	P9CU100-8 P9CU100-7 P9CU100-6 P9CU100-5 P9CU100-4 P9CU100-3 P9CU100-2

ENCLOSURE ONLY	PACKING	CARTON NO. SPECIFY
Model P9CO enclosure only assembled (single pack) 18GA. includes one length each of back panel, front panel, damper-louver plus required support brackets. Panel joiner included with 5', 6' & 8' lengths.	ASSEMBLED	P9CO-8 P9CO-7 P9CO-6 P9CO-5 P9CO-4 P9CO-3 P9CO-2

ELEMENT ONLY	ELEMENT SIZE	CARTON NO. SPECIFY
E75 3/4" CU tube elements only elements and cradles individually boxed.	3/4" CU	E75-8 E75-7 E75-6 E75-5 E75-4 E75-3 E75-2
E100 1" CU tube elements only, elements and cradles individually boxed.	1" CU	E100-8 E100-7 E100-6 E100-5 E100-4 E100-3 E100-2