

LINOVECTOR II

Submittal

LV3-T / LV4-T14 20 24
Copper/Aluminum and
Steel Element Ratings

Specification

LV3 Slip Jointed Enclosure

ENCLOSURE:

STYLE: Flat Top, Top Outlet
OUTLET: Stamped Louvers
Pencil Proof

LENGTHS: 2'0" thru 8'0" in 6" Increments
MAT'L: 16 Ga. CRS (Std)
 14 Ga. CRS (Opt'l)
 16 Ga. Stainless Steel (Opt'l)
 14 Ga. Stainless Steel (Opt'l)
 14 Ga. Aluminum (Opt'l)
 12 Ga. Aluminum (Opt'l)
HEIGHT: 14"
 20" (LV4 only)
 24" (LV4 only)
FINISH: Baked Powder (Std)
 Baked Metallic (Opt'l)

ACCESSORIES:

LV Overlapping Type
All accessories return to the wall at the bottom and have pre-punched holes for fastening to the wall.

LV3-T14

ELEMENT TUBE SIZE	FIN SIZE HEIGHT x WIDTH	CRADLE NUMBER	A
3/4" COPPER	3 1/4 x 3 1/4	2	7"
1" COPPER	3 1/4 x 3 1/4	2	7 3/16"
1 1/4" COPPER	3 1/4 x 3 1/4	1	6 5/8"
1" STEEL	3 1/4 x 3 1/4	2	7 5/16"
1 1/4" STEEL	3 1/4 x 3 1/4	1	6 13/16"

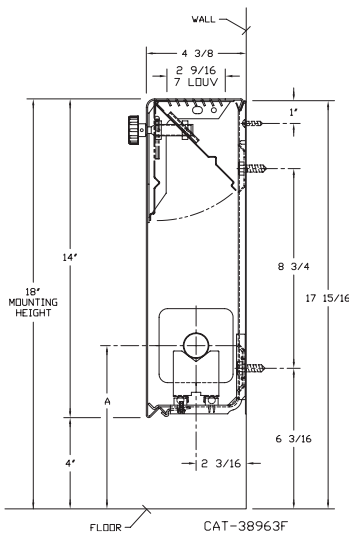

LV4 Slip Jointed Enclosure

BACKPLATE:

TYPE: Partial B/P
LENGTHS: 8'0" Only
MAT'L: 20 Ga. Prepainted (Std)
 18 Ga. Galvannealed (Opt'l)
TYPE: Full Ht. B/P (Opt'l)
LENGTH: 2'0" thru 8'0" in 6" Increments
MAT'L: 20 Ga. Galvannealed (Opt'l)
 20 Ga. Painted (Opt'l)
 18 Ga. Painted (Opt'l)

AIRSEAL:

1/8" x 3/8" Closed Cell (Opt'l)

BRACKETS:

Water Brkt w/B.B.
 Steam Brkt w/Brkt Mtd B.B. Hgr

DAMPER:

Damper Blades Factory Installed
 Knob Damper (Opt'l)
 Tamper Resistant (Opt'l)

LV4-T14 20 24

ELEMENT TUBE SIZE	FIN SIZE HEIGHT x WIDTH	CRADLE NUMBER	A
3/4" COPPER	3 5/8 x 4 1/4	2	7"
3/4" COPPER	4 1/4 x 4 1/4	3A	7 3/8"
1" COPPER	3 5/8 x 4 1/4	2	7 3/16"
1" COPPER	4 1/4 x 4 1/4	2	7 3/16"
1 1/4" COPPER	3 5/8 x 4 1/4	2	7 5/16"
1 1/4" COPPER	4 1/4 x 4 1/4	2	7 5/16"
1" STEEL	4 1/4 x 4 1/4	2	7 5/16"
1 1/4" STEEL	4 1/4 x 4 1/4	2	7 1/2"
2" STEEL	4 1/4 x 4 1/4	1	7 1/4"

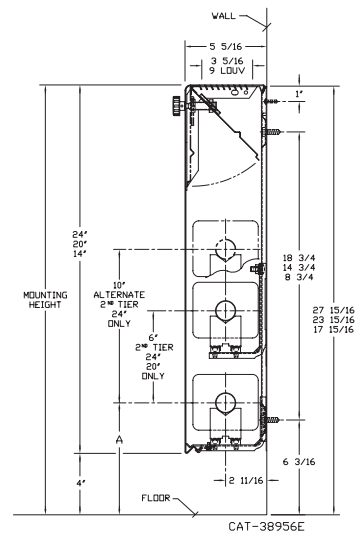

260 North Elm St., Westfield, MA 01085
(413) 568-9571 Fax: (413) 564-5661
www.vulcanrad.com

PROJECT: _____ DATE: _____
LOCATION: _____
ARCHITECT: _____
ENGINEER: _____
CONTRACTOR: _____
PO NUMBER: _____

STYLE "LV3-T / LV4-T 14, 20, 24" LINOVECTOR II

COPPER/ALUMINUM ELEMENTS

ALL RATINGS ARE IN BTU/HR/LIN FT AND BASED ON 3 FPS VELOCITY, 65° EAT

TUBE SIZE	CATALOG DESIGNATION	FIN SIZE HEIGHT X WIDTH	FINS PER FT.	FIN THICKNESS IN INCHES	ENCL HEIGHT IN INCHES	TIERS AND CENTERS IN INCHES	MOUNTING HEIGHT IN INCHES	STEAM 215° FACTOR	HOT WATER (AVG.)								
									200°	190°	180°	170°	160°	150°	140°	130°	120°
									CORRECTION FACTORS FOR AVERAGE WATER TEMPERATURES								
								1.00	0.86	0.78	0.69	0.61	0.53	0.45	.40	.33	.26
3/4"	VC3/4-33	3-1/4" SQ.	32	.020	14	1	18	960	830	750	660	590	510	430	380	320	250
3/4"	VC3/4-34	3-1/4" SQ.	40	.020	14	1	18	1130	970	880	780	690	600	510	450	370	290
3/4"	VC3/4-35	3-1/4" SQ.	50	.020	14	1	18	1280	1100	1000	880	780	680	580	510	420	330
1"	VC33	3-1/4" SQ.	32	.020	14	1	18	940	810	730	650	570	500	420	380	310	240
1"	VC34	3-1/4" SQ.	40	.020	14	1	18	1080	930	840	750	660	570	490	430	360	280
1"	VC35	3-1/4" SQ.	50	.020	14	1	18	1220	1050	950	840	740	650	550	490	400	320
1 1/4"	VC133	3-1/4" SQ.	32	.020	14	1	18	900	770	700	620	550	480	410	360	300	230
1 1/4"	VC134	3-1/4" SQ.	40	.020	14	1	18	1040	890	810	720	630	550	470	420	340	270
1 1/4"	VC135	3-1/4" SQ.	50	.020	14	1	18	1190	1020	930	820	730	630	540	480	390	310
3/4"	VC3/4-433	3-5/8" x 4-1/4"	32	.020	14	1	18	1300	1120	1010	900	790	690	590	520	430	340
					20	1	24	1380	1190	1080	950	840	730	620	550	460	360
					20	2-6 CL	24	2015	1730	1570	1390	1230	1070	910	810	660	520
					24	1	28	1420	1220	1110	980	870	750	640	570	470	370
					24	2-6 CL	28	2100	1810	1640	1450	1280	1110	950	840	690	550
24	3-6 CL	28	2420	2080	1890	1670	1480	1280	1090	970	800	630					
3/4"	VC3/4-434	3-5/8" x 4-1/4"	40	.020	14	1	18	1550	1330	1210	1070	950	820	700	620	510	400
					20	1	24	1650	1420	1290	1140	1010	870	740	660	540	430
					20	2-6 CL	24	2360	2030	1840	1630	1440	1250	1060	940	780	610
					24	1	28	1700	1460	1330	1170	1040	900	770	680	560	440
					24	2-6 CL	28	2460	2120	1920	1700	1500	1300	1110	980	810	640
24	3-6 CL	28	2800	2410	2180	1930	1710	1480	1260	1120	920	730					
3/4"	VC3/4-435	3-5/8" x 4-1/4"	50	.020	14	1	18	1740	1500	1360	1200	1060	920	780	700	570	450
					20	1	24	1870	1610	1460	1290	1140	990	840	750	620	490
					20	2-6 CL	24	2690	2310	2100	1860	1640	1430	1210	1080	890	700
					24	1	28	1960	1690	1530	1350	1200	1040	880	780	650	510
					24	2-6 CL	28	2910	2500	2270	2010	1780	1540	1310	1160	960	760
24	3-6 CL	28	3290	2830	2570	2270	2010	1740	1480	1320	1090	860					
1"	VC433	3-5/8" x 4-1/4"	32	.020	14	1	18	1380	1190	1080	950	840	730	620	550	460	360
					20	1	24	1450	1250	1130	1000	880	770	650	580	480	380
					20	2-6 CL	24	2260	1940	1760	1560	1380	1200	1020	900	750	590
					24	1	28	1490	1280	1160	1030	910	790	670	600	490	390
					24	2-6 CL	28	2340	2010	1830	1610	1430	1240	1050	940	770	610
24	3-6 CL	28	2690	2310	2100	1860	1640	1430	1210	1080	890	700					
1"	VC434	3-5/8" x 4-1/4"	40	.020	14	1	18	1650	1420	1290	1140	1010	870	740	660	540	430
					20	1	24	1710	1470	1330	1180	1040	910	770	680	560	440
					20	2-6 CL	24	2440	2100	1900	1680	1490	1290	1100	980	810	630
					24	1	28	1780	1530	1390	1230	1090	940	800	710	590	460
					24	2-6 CL	28	2530	2180	1970	1750	1540	1340	1140	1010	830	660
24	3-6 CL	28	2880	2480	2250	1990	1760	1530	1300	1150	950	750					
1"	VC435	3-5/8" x 4-1/4"	50	.020	14	1	18	1810	1560	1410	1250	1100	960	810	720	600	470
					20	1	24	1960	1690	1530	1350	1200	1040	880	780	650	510
					20	2-6 CL	24	2520	2170	1970	1740	1540	1340	1130	1010	830	660
					24	1	28	2050	1760	1600	1410	1250	1090	920	820	680	530
					24	2-6 CL	28	2730	2350	2130	1880	1670	1450	1230	1090	900	710
24	3-6 CL	28	3080	2650	2400	2130	1880	1630	1390	1230	1020	800					
1-1/4"	VC1433	3-5/8" x 4-1/4"	32	.020	14	1	18	1350	1160	1050	930	820	720	610	540	450	350
					20	1	24	1420	1220	1110	980	870	750	640	570	470	370
					20	2 @ 6 CL	24	2220	1910	1730	1530	1350	1180	1000	890	730	580
					24	1	28	1460	1260	1140	1010	890	770	660	580	480	380
					24	2 @ 6 CL	28	2300	1980	1790	1590	1400	1220	1040	920	760	600
24	3 @ 6 CL	28	2650	2280	2070	1830	1620	1400	1190	1060	870	690					
1-1/4"	VC1434	3-5/8" x 4-1/4"	40	.020	14	1	18	1580	1360	1230	1090	960	840	710	630	520	410
					20	1	24	1680	1440	1310	1160	1020	890	760	670	550	440
					20	2 @ 6 CL	24	2380	2050	1860	1640	1450	1260	1070	950	790	620
					24	1	28	1740	1500	1360	1200	1060	920	780	700	570	450
					24	2 @ 6 CL	28	2480	2130	1930	1710	1510	1310	1120	990	820	640
24	3 @ 6 CL	28	2830	2430	2210	1950	1730	1500	1270	1130	930	740					
1-1/4"	VC1435	3-5/8" x 4-1/4"	50	.020	14	1	18	1780	1530	1390	1230	1090	940	800	710	590	460
					20	1	24	1920	1650	1500	1320	1170	1020	860	770	630	500
					20	2 @ 6 CL	24	2460	2120	1920	1700	1500	1300	1110	980	810	640
					24	1	28	2010	1730	1570	1390	1230	1070	900	800	660	520
					24	2 @ 6 CL	28	2650	2280	2070	1830	1620	1400	1190	1060	870	690
24	3 @ 6 CL	28	2990	2570	2330	2060	1820	1580	1350	1200	990	780					

STYLE "LV3-T / LV4-T 14, 20, 24" LINOVECTOR II

COPPER/ALUMINUM ELEMENTS

ALL RATINGS ARE IN BTU/HR/LIN FT AND BASED ON 3 FPS VELOCITY, 65° EAT

TUBE SIZE	CATALOG DESIGNATION	FIN SIZE HEIGHT X WIDTH	FINS PER FT.	FIN THICKNESS IN INCHES	ENCL HEIGHT IN INCHES	TIERS AND CENTERS IN INCHES	MOUNTING HEIGHT IN INCHES	STEAM 215° FACTOR	HOT WATER (AVG.)									
									200°	190°	180°	170°	160°	150°	140°	130°	120°	
									CORRECTION FACTORS FOR AVERAGE WATER TEMPERATURES									
									1.00	0.86	0.78	0.69	0.61	0.53	0.45	.40	.33	.26
3/4"	VC3/4-43	4-1/4" SQ.	32	.020	14	1	18	1400	1200	1090	970	850	740	630	560	460	360	
					20	1	24	1595	1370	1240	1100	970	850	720	640	530	410	
					20	2-6 CL	24	2215	1900	1730	1530	1350	1170	1000	890	730	580	
					24	1	28	1530	1320	1190	1060	930	810	690	610	500	400	
					24	2-6 CL	28	2305	1980	1800	1590	1410	1220	1040	920	760	600	
24	3-6 CL	28	2650	2280	2070	1830	1620	1400	1190	1060	920	770	690					
3/4"	VC3/4-44	4-1/4" SQ.	40	.020	14	1	18	1700	1460	1330	1170	1040	900	770	680	560	440	
					20	1	24	1950	1680	1520	1350	1190	1030	880	780	640	510	
					20	2-6 CL	24	2480	2130	1930	1710	1510	1310	1120	990	820	640	
					24	1	28	1870	1610	1460	1290	1140	990	840	750	620	490	
					24	2-6 CL	28	2580	2220	2010	1780	1570	1370	1160	1030	850	670	
24	3-6 CL	28	2940	2530	2290	2030	1790	1560	1320	1180	970	760						
3/4"	VC3/4-45	4-1/4" SQ.	50	.020	14	1	18	1745	1500	1360	1200	1060	920	790	700	580	450	
					20	1	24	2000	1720	1560	1380	1220	1060	900	800	660	520	
					20	2-6 CL	24	2465	2120	1920	1700	1500	1310	1110	990	810	640	
					24	1	28	2060	1770	1610	1420	1260	1090	930	820	680	540	
					24	2-6 CL	28	2480	2130	1930	1710	1510	1310	1120	990	820	640	
24	3-6 CL	28	2800	2410	2180	1930	1710	1480	1260	1120	920	730						
1"	VC43	4-1/4" SQ.	32	.020	14	1	18	1490	1280	1160	1030	910	790	670	600	490	390	
					20	1	24	1550	1330	1210	1070	950	820	700	620	510	400	
					20	2-6 CL	24	2390	2060	1860	1650	1460	1270	1080	960	790	620	
					24	1	28	1600	1380	1250	1100	980	850	720	640	530	420	
					24	2-6 CL	28	2470	2120	1930	1700	1510	1310	1110	990	820	640	
24	3-6 CL	28	2840	2440	2220	1960	1730	1510	1280	1140	940	740						
1"	VC44	4-1/4" SQ.	40	.020	14	1	18	1720	1480	1340	1190	1050	910	770	690	570	450	
					20	1	24	1820	1570	1420	1260	1110	960	820	730	600	470	
					20	2-6 CL	24	2570	2210	2000	1770	1570	1360	1160	1030	850	670	
					24	1	28	1890	1630	1470	1300	1150	1000	850	760	620	490	
					24	2-6 CL	28	2670	2300	2080	1840	1630	1420	1200	1070	880	690	
24	3-6 CL	28	3040	2610	2370	2100	1850	1610	1370	1220	1000	790						
1"	VC45	4-1/4" SQ.	50	.020	14	1	18	1930	1660	1510	1330	1180	1020	870	770	640	500	
					20	1	24	2100	1810	1640	1450	1280	1110	950	840	690	550	
					20	2-6 CL	24	2540	2180	1980	1750	1550	1350	1140	1020	840	660	
					24	1	28	2200	1890	1720	1520	1340	1170	990	880	730	570	
					24	2-6 CL	28	2840	2440	2220	1960	1730	1510	1280	1140	940	740	
24	3-6 CL	28	3210	2760	2500	2210	1960	1700	1440	1280	1060	830						
1-1/4"	VC143	4-1/4" SQ.	32	.020	14	1	18	1460	1260	1140	1010	890	770	660	580	480	380	
					20	1	24	1520	1310	1190	1050	930	810	680	610	500	400	
					20	2-6 CL	24	2350	2020	1830	1620	1430	1250	1060	940	780	610	
					24	1	28	1570	1350	1220	1080	960	830	710	630	520	410	
					24	2-6 CL	28	2430	2090	1900	1680	1480	1290	1090	970	800	630	
24	3-6 CL	28	2790	2400	2180	1930	1700	1480	1260	1120	920	730						
1-1/4"	VC144	4-1/4" SQ.	40	.020	14	1	18	1690	1450	1320	1170	1030	900	760	680	560	440	
					20	1	24	1790	1540	1400	1240	1090	950	810	720	590	470	
					20	2-6 CL	24	2520	2170	1970	1740	1540	1340	1130	1010	830	660	
					24	1	28	1860	1600	1450	1280	1130	990	840	740	610	480	
					24	2-6 CL	28	2620	2250	2040	1810	1600	1390	1180	1050	860	680	
24	3-6 CL	28	2990	2570	2330	2060	1820	1580	1350	1200	990	780						
1-1/4"	VC145	4-1/4" SQ.	50	.020	14	1	18	1900	1630	1480	1310	1160	1010	860	760	630	490	
					20	1	24	2060	1770	1610	1420	1260	1090	930	820	680	540	
					20	2-6 CL	24	2500	2150	1950	1720	1530	1330	1130	1000	830	650	
					24	1	28	2160	1860	1680	1490	1320	1140	970	860	710	560	
					24	2-6 CL	28	2780	2390	2170	1920	1700	1470	1250	1110	920	720	
24	3-6 CL	28	3140	2700	2450	2170	1920	1660	1410	1260	1040	820						

Note: Copper tube furnished flared one end standard.

STYLE "LV3-T / LV4-T 14, 20, 24" LINOVECTOR II

STEEL ELEMENTS

ALL RATINGS ARE IN BTU/HR/LIN FT AND BASED ON 3 FPS VELOCITY, 65° EAT

TUBE SIZE	CATALOG DESIGNATION	FIN SIZE HEIGHT X WIDTH	FINS PER FT.	FIN THICKNESS IN INCHES	ENCL HEIGHT IN INCHES	TIERS AND CENTERS IN INCHES	MOUNTING HEIGHT IN INCHES	STEAM 215° FACTOR	HOT WATER (AVG.)								
									200°	190°	180°	170°	160°	150°	140°	130°	120°
									CORRECTION FACTORS FOR AVERAGE WATER TEMPERATURES								
1"	VS33	3-1/4" SQ.	32	.032	14	1	18	1.00	0.86	0.78	0.69	0.61	0.53	0.45	.40	.33	.26
1"	VS34	3-1/4" SQ.	40	.032	14	1	18	965	830	750	670	590	510	430	390	320	250
1"	VS35	3-1/4" SQ.	50	.032	14	1	18	1035	890	810	710	630	550	470	410	340	270
1-1/4"	VS133	3-1/4" SQ.	32	.032	14	1	18	850	730	660	590	520	450	380	340	280	220
1-1/4"	VS134	3-1/4" SQ.	40	.032	14	1	18	960	830	750	660	590	510	430	380	320	250
1-1/4"	VS135	3-1/4" SQ.	50	.032	14	1	18	1000	860	780	690	610	530	450	400	330	260
1"	VS43	4-1/4" SQ.	32	.032	14	1	18	1200	1030	940	830	730	640	540	480	400	310
					20	1	24	1250	1080	980	860	760	660	560	500	410	330
					20	2-6 CL	24	2030	1750	1580	1400	1240	1080	910	810	670	530
					24	1	28	1280	1100	1000	880	780	680	580	510	420	330
					24	2-6 CL	28	2080	1790	1620	1440	1270	1100	940	830	690	540
24	3-6 CL	28	2390	2060	1860	1650	1460	1270	1080	960	790	620					
1"	VS44	4-1/4" SQ.	40	.032	14	1	18	1420	1220	1110	980	870	750	640	570	470	370
					20	1	24	1500	1290	1170	1040	920	800	680	600	500	390
					20	2-6 CL	24	2200	1890	1720	1520	1340	1170	990	880	730	570
					24	1	28	1560	1340	1220	1080	950	830	700	620	510	410
					24	2-6 CL	28	2270	1950	1770	1570	1380	1200	1020	910	750	590
24	3-6 CL	28	2590	2230	2020	1790	1580	1370	1170	1040	850	670					
1"	VS45	4-1/4" SQ.	50	.032	14	1	18	1485	1280	1160	1020	910	790	670	590	490	390
					20	1	24	1570	1350	1220	1080	960	830	710	630	520	410
					20	2-6 CL	24	2255	1940	1760	1560	1380	1200	1010	900	740	590
					24	1	28	1635	1410	1280	1130	1000	870	740	650	540	430
					24	2-6 CL	28	2325	2000	1810	1600	1420	1230	1050	930	770	600
24	3-6 CL	28	2630	2260	2050	1810	1600	1390	1180	1050	870	680					
1-1/4"	VS143	4-1/4" SQ.	32	.032	14	1	18	1100	950	860	760	670	580	500	440	360	290
					20	1	24	1150	990	900	790	700	610	520	460	380	300
					20	2-6 CL	24	1860	1600	1450	1280	1130	990	840	740	610	480
					24	1	28	1180	1010	920	810	720	630	530	470	390	310
					24	2-6 CL	28	1910	1640	1490	1320	1170	1010	860	760	630	500
24	3-6 CL	28	2200	1890	1720	1520	1340	1170	990	880	730	570					
1-1/4"	VS144	4-1/4" SQ.	40	.032	14	1	18	1410	1210	1100	970	860	750	630	560	470	370
					20	1	24	1490	1280	1160	1030	910	790	670	600	490	390
					20	2-6 CL	24	2190	1880	1710	1510	1340	1160	990	880	720	570
					24	1	28	1550	1330	1210	1070	950	820	700	620	510	400
					24	2-6 CL	28	2260	1940	1760	1560	1380	1200	1020	900	750	590
24	3-6 CL	28	2580	2220	2010	1780	1570	1370	1160	1030	850	670					
1-1/4"	VS145	4-1/4" SQ.	50	.032	14	1	18	1475	1270	1150	1020	900	780	660	590	490	380
					20	1	24	1560	1340	1220	1080	950	830	700	620	510	410
					20	2-6 CL	24	2210	1900	1720	1520	1350	1170	990	880	730	570
					24	1	28	1625	1400	1270	1120	990	860	730	650	540	420
					24	2-6 CL	28	2280	1960	1780	1570	1390	1210	1030	910	750	590
24	3-6 CL	28	2580	2220	2010	1780	1570	1370	1160	1030	850	670					
2"	VS242	4-1/4" SQ.	25	.032	14	1	18	1080	930	840	750	660	570	490	430	360	280
					20	1	24	1120	960	870	770	680	590	500	450	370	290
					20	2-6 CL	24	1790	1540	1400	1240	1090	950	810	720	590	470
					24	1	28	1140	980	890	790	700	600	510	460	380	300
					24	2-6 CL	28	1820	1570	1420	1260	1110	960	820	730	600	470
24	3-6 CL	28	2090	1800	1630	1440	1270	1110	940	840	690	540					
2"	VS243	4-1/4" SQ.	32	.032	14	1	18	1260	1080	980	870	770	670	570	500	420	330
					20	1	24	1310	1130	1020	900	800	690	590	520	430	340
					20	2-6 CL	24	1980	1700	1540	1370	1210	1050	890	790	650	510
					24	1	28	1340	1150	1050	920	820	710	600	540	440	350
					24	2-6 CL	28	2020	1740	1580	1390	1230	1070	910	810	670	530
24	3-6 CL	28	2320	2000	1810	1600	1420	1230	1040	930	770	600					

- Notes: 1) Steel fins furnished as .032 thick, painted black.
 2) NPT threads furnished on steel elements. Please use domestic fittings for proper installation.
 3) The ends can be provided chamfered for field welded fittings when specified.

Steam Bracket and BB Hanger

ELEMENT TUBE SIZE	FIN SIZE HEIGHT x WIDTH	CRADLE NUMBER	A MIN	A MAX
3/4 COPPER	3 1/4 x 3 1/4	2	7 3/8	9 5/8
1" COPPER	3 1/4 x 3 1/4	2	7 1/2	9 3/4
1 1/4 COPPER	3 1/4 x 3 1/4	2	7 5/8	9 7/8
1" STEEL	3 1/4 x 3 1/4	2	7 5/8	9 3/4
1 1/4 STEEL	3 1/4 x 3 1/4	1	7 3/16	9 3/8

ELEMENT TUBE SIZE	FIN SIZE HEIGHT x WIDTH	CRADLE NUMBER	A MIN	A MAX
3/4 COPPER	3 5/8 x 4 1/4	2	7 3/8	8 3/4
	4 1/4 x 4 1/4	3A	7 11/16	9 1/16
1" COPPER	3 5/8 x 4 1/4	2	7 1/2	8 7/8
	4 1/4 x 4 1/4			
1 1/4 COPPER	3 5/8 x 4 1/4	2	7 5/8	9"
	4 1/4 x 4 1/4			
1" STEEL	4 1/4 x 4 1/4	2	7 5/8	9"
1 1/4 STEEL	4 1/4 x 4 1/4	2	7 7/8	9 1/4
2" STEEL	4 1/4 x 4 1/4	1	7 5/8	9"

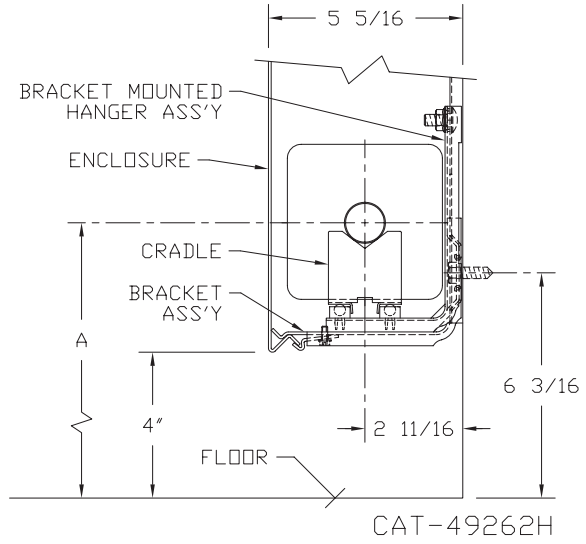
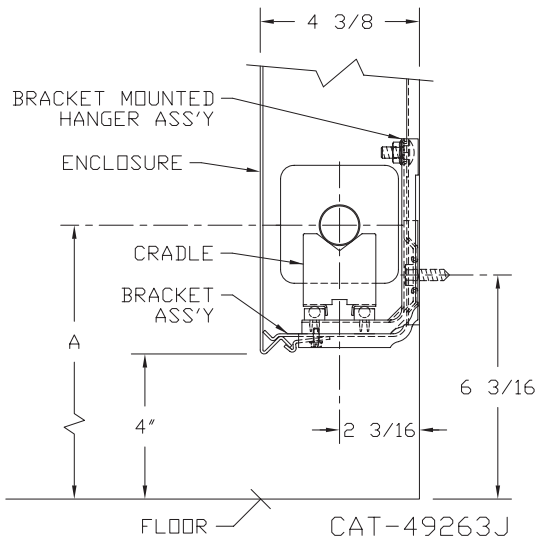

Design Data

Correction Factor Chart for Non-Standard Mounting Heights

MOUNTING HEIGHT (Inches)	ENCLOSURE STYLE						
	BARE FIN ALL SIZES	FRONT OUTLET	FT (FRONT & TOP)		SLOPE		
			3 1/4" FINS	4 1/4" FINS	2 3/4" FINS	3 1/4" FINS	4 1/4" FINS
40 or more	1.000	1.000	1.000	1.000	1.000	1.000	1.000
38	1.000	1.000	1.000	1.000	1.000	1.000	1.003
36	1.000	1.004	1.005	1.005	1.006	1.007	1.009
34	1.010	1.014	1.011	1.010	1.012	1.013	1.016
32	1.020	1.024	1.017	1.015	1.019	1.020	1.025
30	1.030	1.039	1.029	1.024	1.031	1.033	1.039
29	1.040	1.049	1.035	1.029	1.038	1.040	1.045
28	1.050	1.059	1.041	1.034	1.045	1.047	1.052
27	1.060	1.069	1.046	1.039	1.051	1.053	1.059
26	1.070	1.079	1.052	1.044	1.058	1.060	1.065
25	1.080	1.089	1.058	1.049	1.065	1.067	1.072
24	1.090	1.099	1.064	1.054	1.071	1.073	1.079
23	1.100	1.109	1.070	1.059	1.078	1.080	1.085
22	1.110	1.119	1.076	1.064	1.085	1.087	1.092
21	1.120	1.129	1.082	1.069	1.091	1.093	1.099
20	1.130	1.139	1.088	1.074	1.098	1.100	1.100
19	1.140	1.149	1.089	1.075	1.100	1.100	1.100
18 or less	1.150	1.150	1.089	1.075	1.100	1.100	1.100

TOP OUTLET "T" IS NOT AFFECTED.

The AHRI Ratings cataloged include the factor shown for the recommended mounting height.

If the unit is to be installed at a different height than that recommended, the AHRI Rating (except for Top Outlet) must be adjusted as follows: AHRI Rating multiplied by

$$\frac{\text{Factor from Table Above for actual mounting height}}{\text{Factor from Table Above for recommended mounting height}}$$

FORMULA:

$$\text{Catalog Rating} \times \frac{\text{Factor at 30" Height}}{\text{Factor at 18" Height}}$$

$$\text{SOLUTION: } 1950 \times \frac{1.039}{1.150} = 1760 \text{ BTU/Hr.}$$

DYNAMIC FORMULAS

$$\text{BTU} = \text{GPM} \times 500 \times \text{TD}$$

$$\text{GPM} = \left(\frac{\text{BTU}}{500} \right) \div \text{TD}$$

$$\text{TD} = \left(\frac{\text{BTU}}{500} \right) \div \text{GPM}$$

Design Data

COMMERCIAL FINNED TUBE RATING CORRECTION CHARTS

CATALOG FINNED TUBE RATINGS ARE BASED UPON THE FOLLOWING CONDITIONS:

- 215°F AVERAGE WATER OR STEAM TEMPERATURE
- 65°F ENTERING AIR TEMPERATURE
- 3 FEET PER SECOND WATER FLOW RATE
- CATALOG MOUNTING HEIGHT

USE THE FOLLOWING CALCULATION WITH CORRECTION FACTORS FOR JOB CONDITIONS TO DETERMINE CORRECTED RATING:

$$\text{CORRECTED RATING} = (\text{215°F CATALOG RATING}) \times \left(\frac{\text{CORRECTION FACTOR FOR STEAM OR WATER AND AVERAGE AIR TEMP.}}{\text{CORRECTION FACTOR FOR MOUNTING HTG.-SEE CATALOG RATING}} \right) \times \left(\frac{\text{CORRECTION FACTOR FOR FLOW RATE}}{\text{CORRECTION FACTOR FOR MOUNTING HTG.-SEE CATALOG RATING}} \right)$$

USE THE FOLLOWING CHARTS TO SELECT CORRECTION FACTORS

CHART/WATER VEL./CORR. FACTOR / PRESS. DROP/TOTAL BTU.

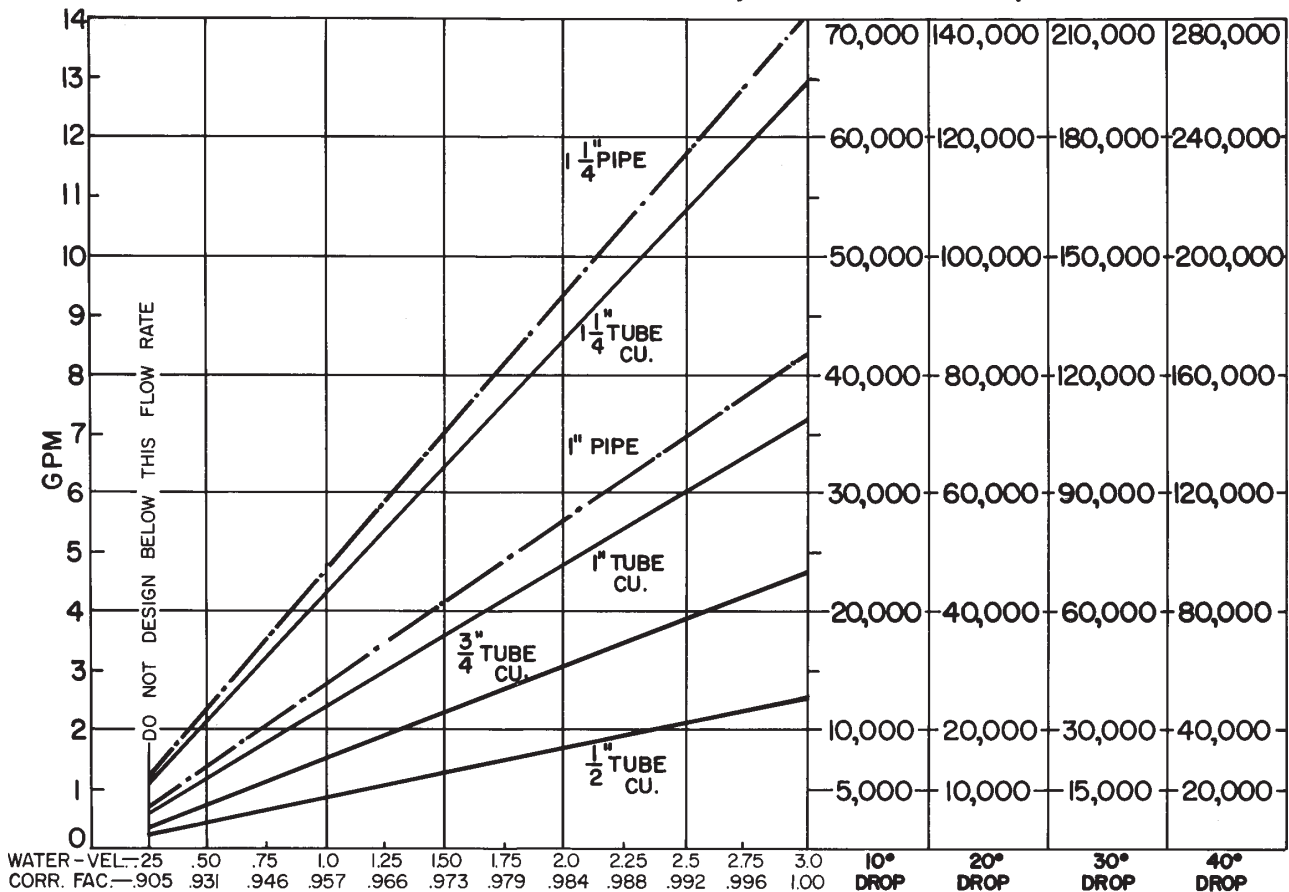

1/2" COP. ALUM.	1.80	2.33	5.33	9.16									
3/4" COP. ALUM.	.5	1.5	3.16	5.4	6.25								
1" COP. ALUM.	.233	.41	.83	1.45	2.16	2.83	3.66						
1" PIPE		.37	.79	1.3	2.00	2.70	3.70	4.80					
1 1/4" COP. ALUM.	.16	.33	.55	.79	1.08	1.33	1.8	2.25	2.26	2.91	3.3		
1 1/4" PIPE	.09	.18	.31	.5	.70	1.0	1.1	1.3	1.6	1.8	2.58	2.3	3.3

PRESSURE DROP PER 100 LINEAR FT., IN FEET OF HEAD

Design Data

INLET AIR CORRECTION FACTOR

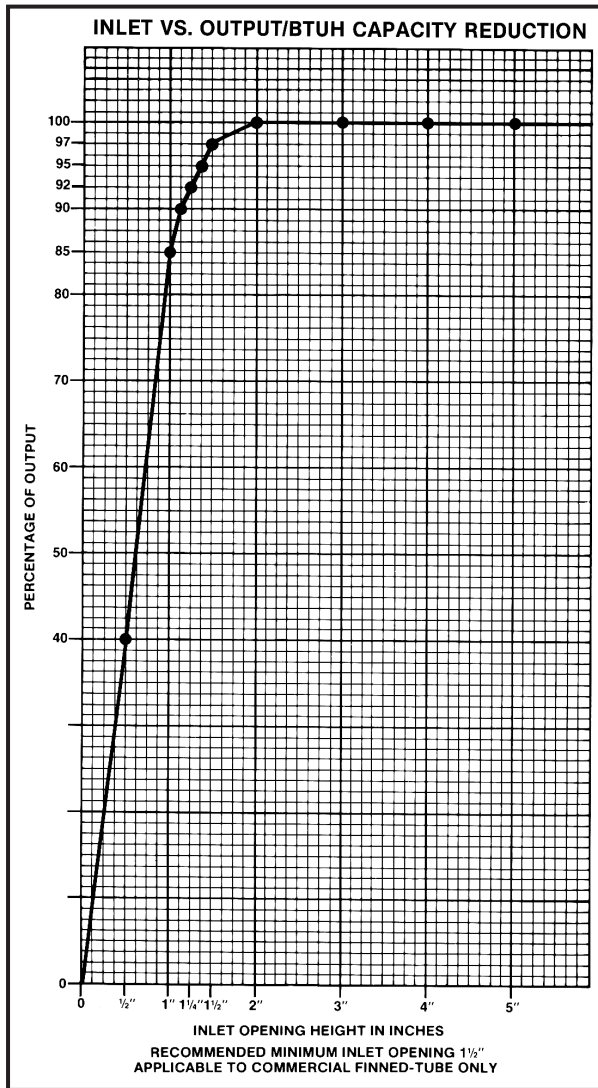

GUARANTEED WORKING PRESSURES

- 1" IPS — 780 AT TEMPERATURES UP TO 650°F.
 - 1 1/4" IPS — 660 AT TEMPERATURES UP TO 650°F.
 - 2" IPS — 405 AT TEMPERATURES UP TO 650°F.
 - 1 1/4" CU — 194 AT TEMPERATURES UP TO 300°F.
 - 1" CU — 204 AT TEMPERATURES UP TO 300°F.
 - 3/4" CU — 218 PSI AT TEMPERATURES UP TO 300°F.
- MAXIMUM PRESSURES AT OTHER TEMPERATURES ARE AVAILABLE UPON REQUEST.

RATE OF PITCH FOR STEAM 1/2" DROP OVER 20 FT. RUN.

PIPE WATER CAPACITIES AND QUANTITIES CIRCULATED AT VELOCITY OF 3* FEET PER SECOND			
Pipe Size	Gals. Per Linear Ft.	Gals./Min. @ 3' Sec. Vel.*	Lbs./Hr. @ 3' Sec. Vel.*
1/2"	.016	2.88	1440
3/4"	.023	4.14	2070
1"	.040	7.20	3600
1 1/4"	.063	11.34	5660
1 1/2"	.102	18.36	9160
2"	.170	30.60	15300
2 1/2"	.275	49.50	24850
3"	.390	70.20	35000

*3 Ft./Sec. Velocity is Basic for Hot Water Rating Factors Shown on this Page.

$$\text{VELOCITY FT./SEC.} = \frac{\text{LBS. PER HOUR}}{(\text{GALS. PER FT.}) (3600) (8.3)}$$

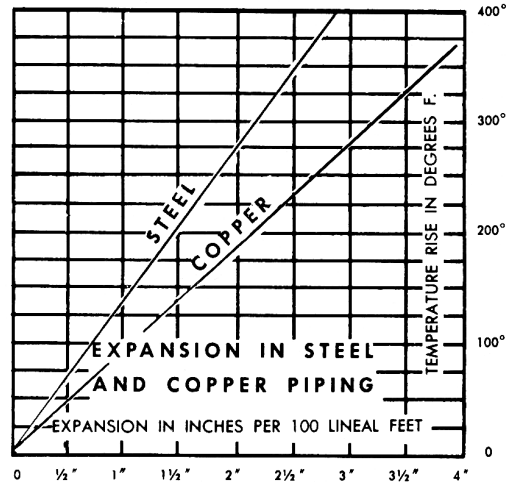

GLYCOL CORRECTION FACTORS

Fluid Temperature 200°F

% Solution	Ethylene Glycol	Propylene Glycol
20	.952	.988
30	.921	.968
40	.888	.943
50	.852	.912

Fluid Temperature 180°F

% Solution	Ethylene Glycol	Propylene Glycol
20	.946	.982
30	.913	.961
40	.879	.934
50	.842	.902

Fluid Temperature 140°F

% Solution	Ethylene Glycol	Propylene Glycol
20	.934	.97
30	.898	.946
40	.861	.916
50	.821	.881

ALTITUDE FACTORS

Approximate factors for convective heat value at varying altitudes

Altitude	Ferrous Units	Copper Alum. Units
Sea Level	1.000	1.000
1,000 ft.	.984	.969
2,000 ft.	.968	.938
3,000 ft.	.952	.908
4,000 ft.	.936	.878
5,000 ft.	.920	.850
6,000 ft.	.904	.822
7,000 ft.	.889	.795
8,000 ft.	.874	.768
9,000 ft.	.859	.743
10,000 ft.	.844	.718
15,000 ft.	.771	.603
20,000 ft.	.703	.502

Design Data

CORRECTION FACTORS FOR STEAM PRESSURES AND AIR TEMPERATURES OTHER THAN STANDARD

STEAM		ENTERING AIR TEMPERATURE, °F														
Pressure		Temp.			STD											
Gauge	Abs. Psi	°F	45	55	65	70	75	80	85	90	100	110	120	130	140	150
(Vac) 15" Hg	7.32	178.9	0.90	0.80	0.70	0.65	0.60	0.56	0.51	0.45	0.39	0.32	0.25	0.18	0.13	0.08
(Vac) 10"	9.78	192.2	1.02	0.91	0.81	0.76	0.71	0.66	0.62	0.55	0.48	0.40	0.33	0.26	0.20	0.14
(Vac) 5"	12.25	202.9	1.11	1.00	0.90	0.85	0.79	0.75	0.70	0.63	0.56	0.48	0.40	0.33	0.27	0.20
(Vac) 0 Psi	14.696	212.0	1.19	1.09	0.97	0.92	0.87	0.82	0.77	0.70	0.63	0.54	0.46	0.38	0.31	0.25
▶ .899	15.595	215.0	1.22	1.11	1.00	0.95	0.90	0.84	0.80	0.75	0.65	0.57	0.48	0.40	0.33	0.26
5	19.70	227.1	1.34	1.22	1.11	1.05	1.00	0.95	0.90	0.81	0.75	0.66	0.57	0.49	0.41	0.34
10	24.70	239.4	1.45	1.33	1.22	1.17	1.11	1.05	1.00	0.91	0.85	0.75	0.66	0.58	0.50	0.42
15	29.70	249.8	1.55	1.43	1.31	1.26	1.20	1.14	1.09	1.00	0.94	0.84	0.75	0.66	0.57	0.49
20	34.70	258.8	1.63	1.52	1.40	1.33	1.28	1.23	1.17	1.07	1.02	0.92	0.82	0.73	0.64	0.55
25	39.70	266.8	1.71	1.59	1.47	1.41	1.36	1.30	1.25	1.15	1.09	0.98	0.89	0.80	0.71	0.62
30	44.70	274.0	1.78	1.66	1.54	1.48	1.42	1.37	1.31	1.21	1.15	1.05	0.95	0.85	0.76	0.68
40	54.70	286.7	1.91	1.79	1.66	1.61	1.54	1.49	1.43	1.32	1.27	1.16	1.06	0.97	0.87	0.78
50	64.70	297.7	2.02	1.90	1.77	1.71	1.65	1.60	1.54	1.42	1.37	1.26	1.16	1.06	0.96	0.87
60	74.70	307.3	2.10	2.00	1.87	1.81	1.75	1.69	1.63	1.51	1.47	1.35	1.25	1.15	1.05	0.95
70	84.70	316.0	2.20	2.09	1.95	1.89	1.83	1.77	1.71	1.59	1.55	1.44	1.33	1.23	1.12	1.03
80	94.70	323.9	2.27	2.17	2.03	1.97	1.91	1.85	1.80	1.69	1.63	1.52	1.41	1.31	1.20	1.10
90	104.70	331.2	2.36	2.24	2.11	2.05	1.98	1.93	1.87	1.74	1.70	1.59	1.48	1.38	1.28	1.17
100	114.70	337.9	2.43	2.31	2.18	2.11	2.05	2.00	1.94	1.81	1.77	1.65	1.54	1.44	1.33	1.23
125	139.70	352.9	2.59	2.47	2.33	2.27	2.21	2.16	2.10	1.96	1.92	1.80	1.69	1.59	1.48	1.38
150	164.70	365.9	2.73	2.62	2.47	2.43	2.35	2.29	2.23	2.08	2.05	1.94	1.82	1.72	1.61	1.51
175	189.70	377.4	2.86	2.74	2.60	2.54	2.47	2.41	2.35	2.21	2.17	2.05	1.95	1.85	1.73	1.63
200	214.70	387.8	2.95	2.85	2.71	2.63	2.58	2.52	2.47	2.31	2.29	2.17	2.06	1.96	1.84	1.75

From Keenan and Keyes — Linear Interpolation.

Note: Gauge pressure should be corrected for altitude.

CORRECTION FACTORS FOR WATER TEMPERATURES AND AIR TEMPERATURES OTHER THAN STANDARD

AVERAGE WATER TEMP. °F	ENTERING AIR TEMPERATURE, °F														
	45	55	STD	70	75	80	85	90	95	100	110	120	130	140	150
90	.19	.13	.11	.06											
100	.25	.19	.15	.11	.08	.06									
110	.31	.25	.20	.16	.13	.11	.08	.06							
120	.38	.31	.26	.21	.19	.16	.13	.11	.08	.06					
130	.45	.38	.33	.28	.25	.21	.19	.16	.13	.11	.06				
140	.53	.45	.40	.34	.31	.28	.25	.21	.19	.16	.11	.06			
150	.61	.53	.45	.41	.38	.34	.31	.28	.25	.21	.16	.11	.06		
160	.69	.61	.53	.49	.45	.41	.38	.34	.31	.28	.21	.16	.11	.06	
170	.77	.69	.61	.57	.53	.49	.45	.41	.38	.34	.28	.21	.16	.11	.06
180	.86	.77	.69	.65	.61	.57	.53	.49	.45	.41	.34	.28	.21	.16	.11
190	.95	.86	.78	.73	.69	.65	.61	.57	.53	.49	.41	.34	.28	.21	.16
200	1.05	.95	.86	.82	.77	.73	.69	.65	.61	.57	.49	.41	.34	.28	.21
210	1.14	1.05	.95	.91	.86	.82	.77	.73	.69	.65	.57	.49	.41	.34	.28
▶ 215 (STD.)	1.19	1.09	1.00	.95	.91	.86	.82	.77	.73	.69	.61	.53	.45	.38	.31
220	1.24	1.14	1.05	1.00	.95	.91	.86	.82	.77	.73	.65	.57	.49	.41	.34
230	1.34	1.24	1.14	1.09	1.05	1.00	.95	.91	.86	.82	.73	.65	.57	.49	.41
240	1.44	1.34	1.25	1.19	1.14	1.09	1.05	1.00	.95	.91	.82	.73	.65	.57	.49
250	1.55	1.44	1.34	1.29	1.24	1.19	1.14	1.09	1.05	1.00	.91	.82	.73	.65	.57
260	1.66	1.55	1.44	1.39	1.34	1.29	1.24	1.19	1.14	1.09	1.00	.91	.82	.73	.65
270	1.76	1.66	1.55	1.50	1.44	1.39	1.34	1.29	1.24	1.19	1.09	1.00	.91	.82	.73
280	1.87	1.76	1.66	1.60	1.55	1.50	1.44	1.39	1.34	1.29	1.19	1.09	1.00	.91	.82
290	1.99	1.87	1.76	1.71	1.66	1.60	1.55	1.50	1.44	1.39	1.29	1.19	1.09	1.00	.91
300	2.10	1.99	1.87	1.82	1.76	1.71	1.66	1.60	1.55	1.50	1.39	1.29	1.19	1.09	1.00