

LINOVECTOR II

LV4-PM PM2
Copper/Aluminum and
Steel Element Ratings

Submittal

Specification

LV4 Slip Jointed Enclosure

ENCLOSURE:

STYLE: Pedestal Mounted, Top Outlet
OUTLET: Stamped Louvers
Pencil Proof

LENGTHS: 2'0" thru 8'0" in 6" Increments

MAT'L: 16 Ga. CRS (Std)
 14 Ga. CRS (Opt'l)
 16 Ga. Stainless Steel (Opt'l)
 14 Ga. Stainless Steel (Opt'l)
 14 Ga. Aluminum (Opt'l)
 12 Ga. Aluminum (Opt'l)

FINISH: Baked Powder (Std)
 Baked Metallic (Opt'l)

ACCESSORIES:

LV Overlapping Type

ELEMENT:

TYPE: Cu/AL (Mechanically Expanded)

LENGTHS: 2'0" thru 12'6" in 1" Increments
for 1" & 1-1/4" Cu.
2'0" thru 8'0" in 1" Increments
for 3/4" Cu.

One End Flared (Std)

TYPE: IPS Steel (Mechanically Expanded)

LENGTHS: 2'0" thru 12'6" in 1" Increments
 Thread both Ends (Std)
 Beveled Ends for Field Weld (Opt'l)

See Catalog for Working Pressures

BRACKETS:

Pedestal Brkt w/ B.B.
Floor Mounted

DAMPER: Not Available

LV4-PM

ELEMENT TUBE SIZE	FIN SIZE HEIGHT x WIDTH	CRADLE NUMBER	A
3/4 COPPER	3 5/8 x 4 1/4	2	6 7/16
3/4 COPPER	4 1/4 x 4 1/4	3A	6 13/16
1" COPPER	3 5/8 x 4 1/4	2	6 5/8
1" COPPER	4 1/4 x 4 1/4	2	6 5/8
1 1/4 COPPER	3 5/8 x 4 1/4	2	6 3/4
1 1/4 COPPER	4 1/4 x 4 1/4	2	6 3/4
1" STEEL	4 1/4 x 4 1/4	2	6 3/4
1 1/4 STEEL	4 1/4 x 4 1/4	2	6 15/16
2" STEEL	4 1/4 x 4 1/4	1	6 11/16

LV4-PM2

ELEMENT TUBE SIZE	FIN SIZE HEIGHT x WIDTH	CRADLE NUMBER	A
3/4 COPPER	3 5/8 x 4 1/4	2	6 7/16
3/4 COPPER	4 1/4 x 4 1/4	3A	6 13/16
1" COPPER	3 5/8 x 4 1/4	2	6 5/8
1" COPPER	4 1/4 x 4 1/4	2	6 5/8
1 1/4 COPPER	3 5/8 x 4 1/4	2	6 3/4
1 1/4 COPPER	4 1/4 x 4 1/4	2	6 3/4
1" STEEL	4 1/4 x 4 1/4	2	6 3/4
1 1/4 STEEL	4 1/4 x 4 1/4	2	6 15/16
2" STEEL	4 1/4 x 4 1/4	1	6 11/16

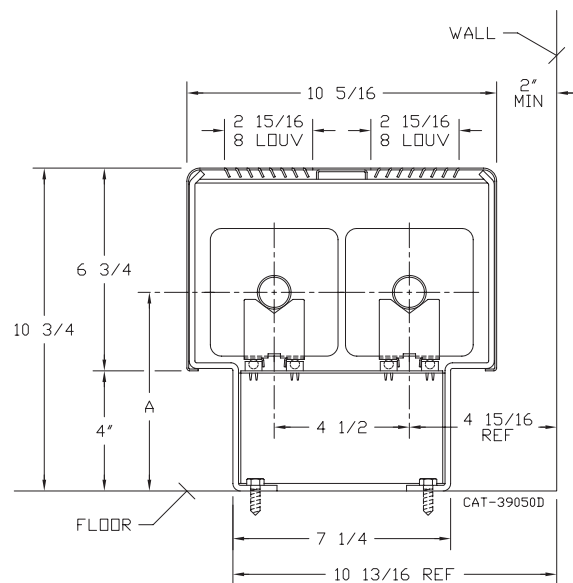
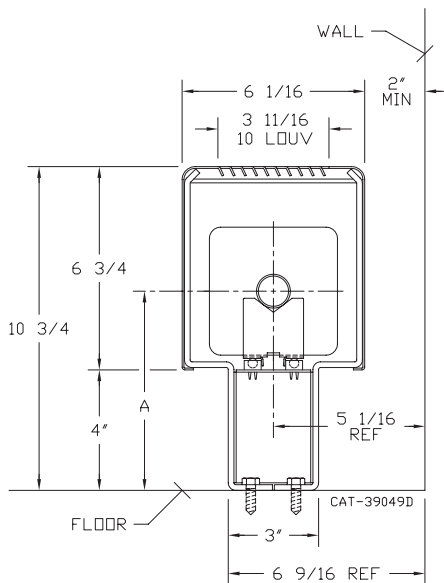

Vulcan

RADIATOR

260 North Elm St., Westfield, MA 01085
(413) 568-9571 Fax: (413) 564-5661
www.vulcanrad.com

PROJECT: _____ DATE: _____

LOCATION: _____

ARCHITECT: _____

ENGINEER: _____

CONTRACTOR: _____

PO NUMBER: _____

STYLE "LV4-PM PM2" LINOVECTOR II PEDESTAL

COPPER/ALUMINUM ELEMENTS

ALL RATINGS ARE IN BTU/HR/LIN FT AND BASED ON 3 FPS VELOCITY, 65° EAT

TUBE SIZE	CATALOG DESIGNATION	FIN SIZE HEIGHT X WIDTH	FINS PER FT.	FIN THICKNESS IN INCHES	ENCL DEPTH IN INCHES	ROWS AND CENTERS IN INCHES	MOUNTING HEIGHT IN INCHES	STEAM 215° FACTOR	HOT WATER (AVG.)								
									200°	190°	180°	170°	160°	150°	140°	130°	120°
									CORRECTION FACTORS FOR AVERAGE WATER TEMPERATURES								
3/4"	VC3/4-433	3-5/8" x 4-1/4"	32	.020	6 3/4 10 5/16	1 2 - 4 1/2	10 3/4 "	1.00 2080	0.86 1790	0.78 1620	0.69 1440	0.61 1270	0.53 1100	0.45 940	.40 830	.33 690	.26 540
3/4"	VC3/4-434	3-5/8" x 4-1/4"	40	.020	6 3/4 10 5/16	1 2 - 4 1/2	10 3/4 "	1250 2490	1080 2140	980 1940	860 1720	760 1520	660 1320	560 1120	420 1000	340 820	270 650
3/4"	VC3/4-435	3-5/8" x 4-1/4"	50	.020	6 3/4 10 5/16	1 2 - 4 1/2	10 3/4 "	1380 2750	1190 2370	1080 2150	950 1900	840 1680	730 1460	620 1240	550 1100	460 910	360 720
1"	VC433	3-5/8" x 4-1/4"	32	.020	6 3/4 10 5/16	1 2 - 4 1/2	10 3/4 "	1080 2170	930 1870	840 1690	750 1500	660 1320	570 1150	490 980	430 870	360 720	280 560
1"	VC434	3-5/8" x 4-1/4"	40	.020	6 3/4 10 5/16	1 2 - 4 1/2	10 3/4 "	1210 2430	1040 2090	940 1900	830 1680	740 1480	640 1290	540 1090	480 970	400 800	310 630
1"	VC435	3-5/8" x 4-1/4"	50	.020	6 3/4 10 5/16	1 2 - 4 1/2	10 3/4 "	1380 2750	1190 2370	1080 2150	950 1900	840 1680	730 1460	620 1240	550 1100	460 910	360 720
1-1/4"	VC1433	3-5/8" x 4-1/4"	32	.020	6 3/4 10 5/16	1 2 - 4 1/2	10 3/4 "	1130 2250	970 1940	880 1760	780 1550	690 1370	600 1190	510 1010	450 900	370 740	290 590
1-1/4"	VC1434	3-5/8" x 4-1/4"	40	.020	6 3/4 10 5/16	1 2 - 4 1/2	10 3/4 "	1240 2480	1070 2130	970 1930	860 1710	760 1510	660 1310	560 1120	500 990	410 820	320 640
1-1/4"	VC1435	3-5/8" x 4-1/4"	50	.020	6 3/4 10 5/16	1 2 - 4 1/2	10 3/4 "	1380 2750	1190 2370	1080 2150	950 1900	840 1680	730 1460	620 1240	550 1100	460 910	360 720
3/4"	VC3/4-43	4-1/4" SQ.	32	.020	6 3/4 10 5/16	1 2 - 4 1/2	10 3/4 "	1150 2300	990 1980	900 1790	790 1590	700 1400	610 1220	520 1040	460 920	380 760	300 600
3/4"	VC3/4-44	4-1/4" SQ.	40	.020	6 3/4 10 5/16	1 2 - 4 1/2	10 3/4 "	1380 2750	1190 2370	1080 2150	950 1900	840 1680	730 1460	620 1240	550 1100	460 910	360 720
3/4"	VC3/4-45	4-1/4" SQ.	50	.020	6 3/4 10 5/16	1 2 - 4 1/2	10 3/4 "	1420 2840	1220 2440	1110 2220	980 1960	870 1730	750 1510	640 1280	570 1140	470 940	370 740
1"	VC43	4-1/4" SQ.	32	.020	6 3/4 10 5/16	1 2 - 4 1/2	10 3/4 "	1150 2300	990 1980	900 1790	790 1590	700 1400	610 1220	520 1040	460 920	380 760	300 600
1"	VC44	4-1/4" SQ.	40	.020	6 3/4 10 5/16	1 2 - 4 1/2	10 3/4 "	1280 2560	1100 2200	1000 2000	880 1770	780 1560	680 1360	580 1150	510 1020	420 840	330 670
1"	VC45	4-1/4" SQ.	50	.020	6 3/4 10 5/16	1 2 - 4 1/2	10 3/4 "	1440 2890	1240 2490	1120 2250	990 1990	880 1760	760 1530	650 1300	580 1160	480 950	370 750
1-1/4"	VC143	4-1/4" SQ.	32	.020	6 3/4 10 5/16	1 2 - 4 1/2	10 3/4 "	1200 2410	1030 2070	940 1880	830 1660	730 1470	640 1280	540 1080	480 960	400 800	310 630
1-1/4"	VC144	4-1/4" SQ.	40	.020	6 3/4 10 5/16	1 2 - 4 1/2	10 3/4 "	1430 2860	1230 2460	1120 2230	990 1970	870 1740	760 1520	640 1290	570 1140	470 940	370 740
1-1/4"	VC145	4-1/4" SQ.	50	.020	6 3/4 10 5/16	1 2 - 4 1/2	10 3/4 "	1470 2940	1260 2530	1150 2290	1010 2030	900 1790	780 1560	660 1320	590 1180	490 970	380 760

Note: Copper tube furnished flared one end standard.

STEEL ELEMENTS

ALL RATINGS ARE IN BTU/HR/LIN FT AND BASED ON 3 FPS VELOCITY, 65° EAT

TUBE SIZE	CATALOG DESIGNATION	FIN SIZE HEIGHT X WIDTH	FINS PER FT.	FIN THICKNESS IN INCHES	ENCL DEPTH IN INCHES	ROWS AND CENTERS IN INCHES	MOUNTING HEIGHT IN INCHES	STEAM 215° FACTOR	HOT WATER (AVG.)								
									200°	190°	180°	170°	160°	150°	140°	130°	120°
									CORRECTION FACTORS FOR AVERAGE WATER TEMPERATURES								
1"	VS43	4-1/4" SQ.	32	.032	6 3/4 10 5/16	1 2 - 4 1/2	10 3/4 10 3/4	1140 2270	980 1950	890 1770	790 1570	700 1380	600 1200	510 1020	460 910	380 750	300 590
1"	VS44	4-1/4" SQ.	40	.032	6 3/4 10 5/16	1 2 - 4 1/2	10 3/4 10 3/4	1280 2560	1100 2200	1000 2000	880 1770	780 1560	680 1360	580 1150	510 1020	420 840	330 670
1"	VS45	4-1/4" SQ.	50	.032	6 3/4 10 5/16	1 2 - 4 1/2	10 3/4 10 3/4	1360 2720	1170 2340	1060 2120	940 1880	830 1660	720 1440	610 1220	540 1090	450 900	350 710
1-1/4"	VS143	4-1/4" SQ.	32	.032	6 3/4 10 5/16	1 2 - 4 1/2	10 3/4 10 3/4	1050 2100	900 1810	820 1640	720 1450	640 1280	560 1110	470 950	420 840	350 690	270 550
1-1/4"	VS144	4-1/4" SQ.	40	.032	6 3/4 10 5/16	1 2 - 4 1/2	10 3/4 10 3/4	1270 2550	1090 2190	990 1990	880 1760	770 1560	670 1350	570 1150	510 1020	420 840	330 660
1-1/4"	VS145	4-1/4" SQ.	50	.032	6 3/4 10 5/16	1 2 - 4 1/2	10 3/4 10 3/4	1330 2670	1140 2300	1040 2080	920 1840	810 1630	700 1420	600 1200	530 1070	440 880	350 690
2"	VS242	4-1/4" SQ.	25	.032	6 3/4 10 5/16	1 2 - 4 1/2	10 3/4 10 3/4	980 1960	840 1690	760 1530	680 1350	600 1200	520 1040	440 880	390 780	320 650	250 510
2"	VS243	4-1/4" SQ.	32	.032	6 3/4 10 5/16	1 2 - 4 1/2	10 3/4 10 3/4	1140 2270	980 1950	890 1770	790 1570	700 1380	600 1200	510 1020	460 910	380 750	300 590

- Notes: 1) Steel fins furnished as .032 thick, painted black.
 2) NPT threads furnished on steel elements. Please use domestic fittings for proper installation.
 3) Ratings based on typical window wall installation.
 4) The ends can be provided chamfered for field welded fittings when specified.

STYLE "LV4-PM PM2" LINOVECTOR II PEDESTAL

ALTERNATE PIPING CAPABILITY WITH 3/4" AND 1" COPPER TUBE ELEMENTS

LV4-PM WITH RETURN ABOVE ELEMENT

ELEMENT TUBE SIZE	FIN SIZE HEIGHT x WIDTH	CRADLE NUMBER	A	B WITH 3/4 RETURN
3/4 COPPER	3 5/8 x 4 1/4	2	6 7/16	2 3/8
3/4 COPPER	4 1/4 x 4 1/4	3A	6 13/16	2 11/16
1" COPPER	3 5/8 x 4 1/4	2	6 5/8	2 1/2
1" COPPER	4 1/4 x 4 1/4	2	6 5/8	2 7/8

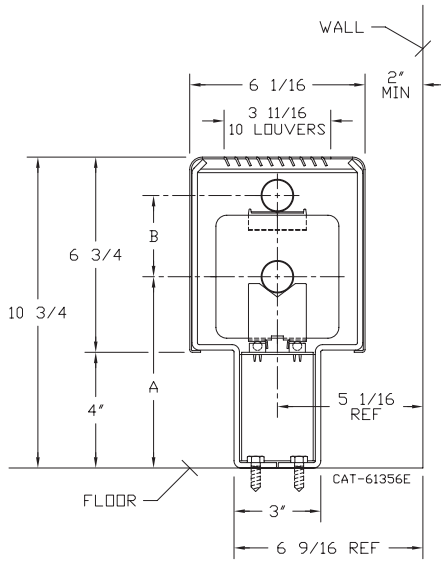

LV4-PM WITH RETURN BELOW ELEMENT

ELEMENT TUBE SIZE	FIN SIZE HEIGHT x WIDTH	CRADLE NUMBER	A	B WITH 3/4 RETURN	B WITH 1" RETURN
3/4 COPPER	3 5/8 x 4 1/4	6	7 3/16	2 1/2	2 3/8
3/4 COPPER	4 1/4 x 4 1/4	10	7 3/8	2 11/16	N/A
1" COPPER	3 5/8 x 4 1/4	6	7 3/8	2 11/16	2 9/16
1" COPPER	4 1/4 x 4 1/4	10	7 9/16	2 7/8	2 3/4

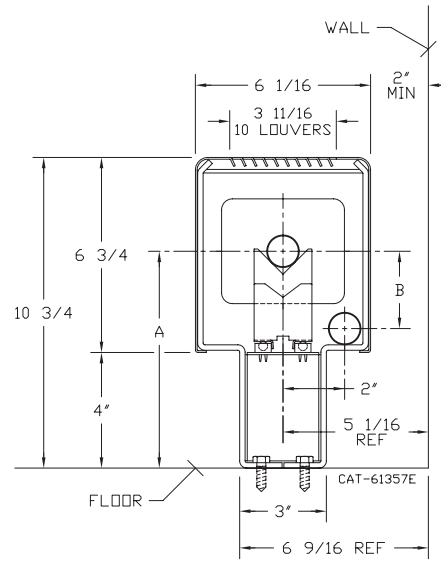

ADJUSTABLE BRACKET FOR STEAM APPLICATIONS

ELEMENT TUBE SIZE	FIN SIZE HEIGHT x WIDTH	CRADLE NUMBER	A MIN	A MAX
3/4 COPPER	3 5/8 x 4 1/4	2	6 1/2	8"
3/4 COPPER	4 1/4 x 4 1/4	3A	6 11/16	
1" COPPER	3 5/8 x 4 1/4	2	6 1/2	
1" COPPER	4 1/4 x 4 1/4	2	6 1/2	
1 1/4 COPPER	3 5/8 x 4 1/4	2	6 5/8	
1 1/4 COPPER	4 1/4 x 4 1/4	2	6 5/8	
1" STEEL	4 1/4 x 4 1/4	2	6 5/8	
1 1/4 STEEL	4 1/4 x 4 1/4	2	6 3/4	
2" STEEL	4 1/4 x 4 1/4	1	6 1/2	

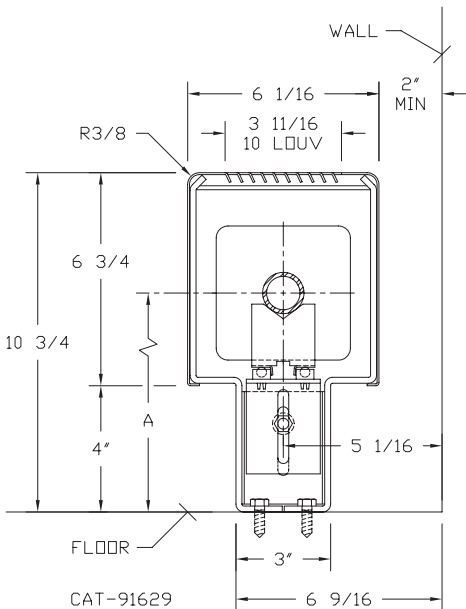

ELEMENT TUBE SIZE	FIN SIZE HEIGHT x WIDTH	CRADLE NUMBER	A MIN	A MAX
3/4 COPPER	3 5/8 x 4 1/4	2	6 1/2	8"
3/4 COPPER	4 1/4 x 4 1/4	3A	6 11/16	
1" COPPER	3 5/8 x 4 1/4	2	6 1/2	
1" COPPER	4 1/4 x 4 1/4	2	6 1/2	
1 1/4 COPPER	3 5/8 x 4 1/4	2	6 5/8	
1 1/4 COPPER	4 1/4 x 4 1/4	2	6 5/8	
1" STEEL	4 1/4 x 4 1/4	2	6 5/8	
1 1/4 STEEL	4 1/4 x 4 1/4	2	6 3/4	
2" STEEL	4 1/4 x 4 1/4	1	6 1/2	

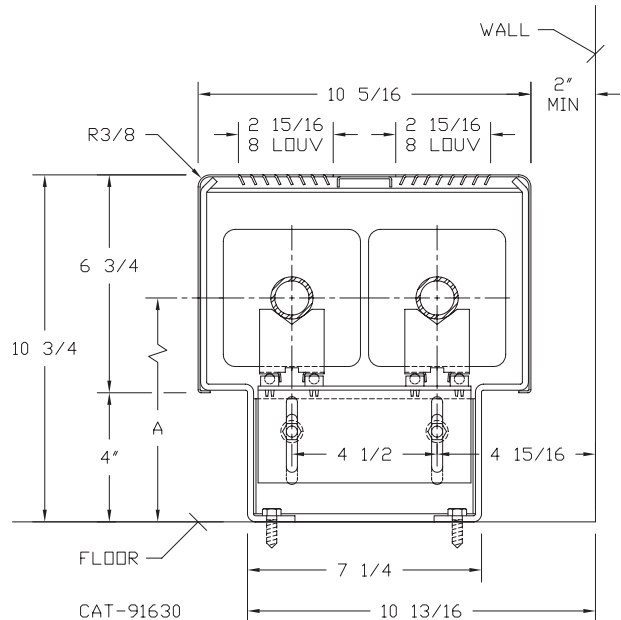

Design Data

Correction Factor Chart for Non-Standard Mounting Heights

MOUNTING HEIGHT (Inches)	ENCLOSURE STYLE						
	BARE FIN ALL SIZES	FRONT OUTLET	FT (FRONT & TOP)		SLOPE		
			3 1/4" FINS	4 1/4" FINS	2 3/4" FINS	3 1/4" FINS	4 1/4" FINS
40 or more	1.000	1.000	1.000	1.000	1.000	1.000	1.000
38	1.000	1.000	1.000	1.000	1.000	1.000	1.003
36	1.000	1.004	1.005	1.005	1.006	1.007	1.009
34	1.010	1.014	1.011	1.010	1.012	1.013	1.016
32	1.020	1.024	1.017	1.015	1.019	1.020	1.025
30	1.030	1.039	1.029	1.024	1.031	1.033	1.039
29	1.040	1.049	1.035	1.029	1.038	1.040	1.045
28	1.050	1.059	1.041	1.034	1.045	1.047	1.052
27	1.060	1.069	1.046	1.039	1.051	1.053	1.059
26	1.070	1.079	1.052	1.044	1.058	1.060	1.065
25	1.080	1.089	1.058	1.049	1.065	1.067	1.072
24	1.090	1.099	1.064	1.054	1.071	1.073	1.079
23	1.100	1.109	1.070	1.059	1.078	1.080	1.085
22	1.110	1.119	1.076	1.064	1.085	1.087	1.092
21	1.120	1.129	1.082	1.069	1.091	1.093	1.099
20	1.130	1.139	1.088	1.074	1.098	1.100	1.100
19	1.140	1.149	1.089	1.075	1.100	1.100	1.100
18 or less	1.150	1.150	1.089	1.075	1.100	1.100	1.100

TOP OUTLET "T" IS NOT AFFECTED.

The AHRI Ratings cataloged include the factor shown for the recommended mounting height.

If the unit is to be installed at a different height than that recommended, the AHRI Rating (except for Top Outlet) must be adjusted as follows: AHRI Rating multiplied by

$$\frac{\text{Factor from Table Above for actual mounting height}}{\text{Factor from Table Above for recommended mounting height}}$$

FORMULA:

$$\text{Catalog Rating} \times \frac{\text{Factor at 30" Height}}{\text{Factor at 18" Height}}$$

$$\text{SOLUTION: } 1950 \times \frac{1.039}{1.150} = 1760 \text{ BTU/Hr.}$$

DYNAMIC FORMULAS

$$\text{BTU} = \text{GPM} \times 500 \times \text{TD}$$

$$\text{GPM} = \left(\frac{\text{BTU}}{500} \right) \div \text{TD}$$

$$\text{TD} = \left(\frac{\text{BTU}}{500} \right) \div \text{GPM}$$

Design Data

COMMERCIAL FINNED TUBE RATING CORRECTION CHARTS

CATALOG FINNED TUBE RATINGS ARE BASED UPON THE FOLLOWING CONDITIONS:

- 215°F AVERAGE WATER OR STEAM TEMPERATURE
- 65°F ENTERING AIR TEMPERATURE
- 3 FEET PER SECOND WATER FLOW RATE
- CATALOG MOUNTING HEIGHT

USE THE FOLLOWING CALCULATION WITH CORRECTION FACTORS FOR JOB CONDITIONS TO DETERMINE CORRECTED RATING:

$$\text{CORRECTED RATING} = (\text{215°F CATALOG RATING}) \times \left(\frac{\text{CORRECTION FACTOR FOR STEAM OR WATER AND AVERAGE AIR TEMP.}}{\text{CORRECTION FACTOR FOR MOUNTING HTG.-SEE CATALOG RATING}} \right) \times \left(\frac{\text{CORRECTION FACTOR FOR FLOW RATE}}{\text{CORRECTION FACTOR FOR MOUNTING HTG.-SEE CATALOG RATING}} \right)$$

USE THE FOLLOWING CHARTS TO SELECT CORRECTION FACTORS

CHART/WATER VEL./CORR. FACTOR / PRESS. DROP/TOTAL BTU.

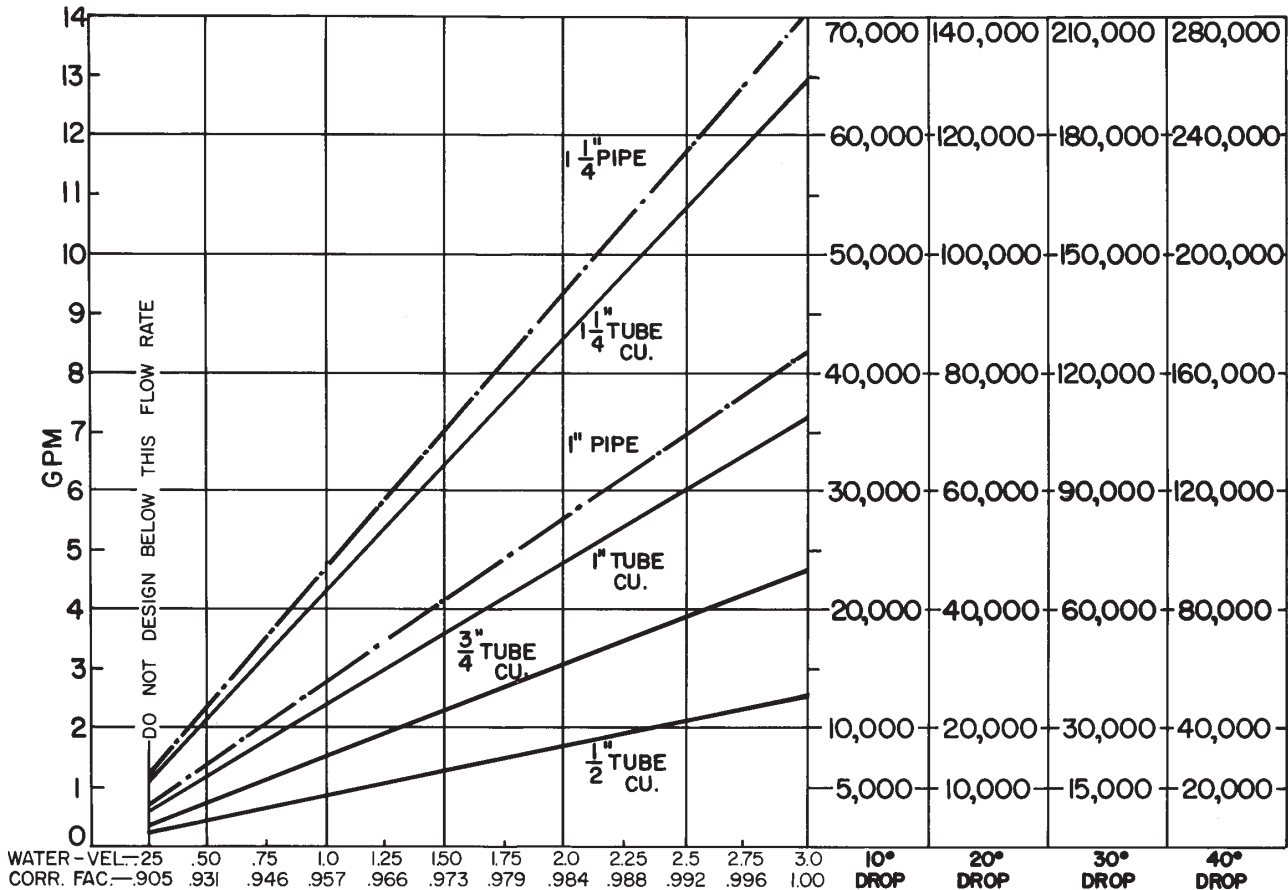

1/2" COP. ALUM.	1.80	2.33	5.33	9.16									
3/4" COP. ALUM.	.5	1.5	3.16	5.4	6.25								
1" COP. ALUM.	.233	.41	.83	1.45	2.16	2.83	3.66						
1" PIPE		.37	.79	1.3	2.00	2.70	3.70	4.80					
1 1/4" COP. ALUM.	.16	.33	.55	.79	1.08	1.33	1.8	2.25	2.26	2.91	3.3		
1 1/4" PIPE	.09	.18	.31	.5	.70	1.0	1.1	1.3	1.6	1.8	2.58	2.3	3.3

PRESSURE DROP PER 100 LINEAR FT., IN FEET OF HEAD

Design Data

INLET AIR CORRECTION FACTOR

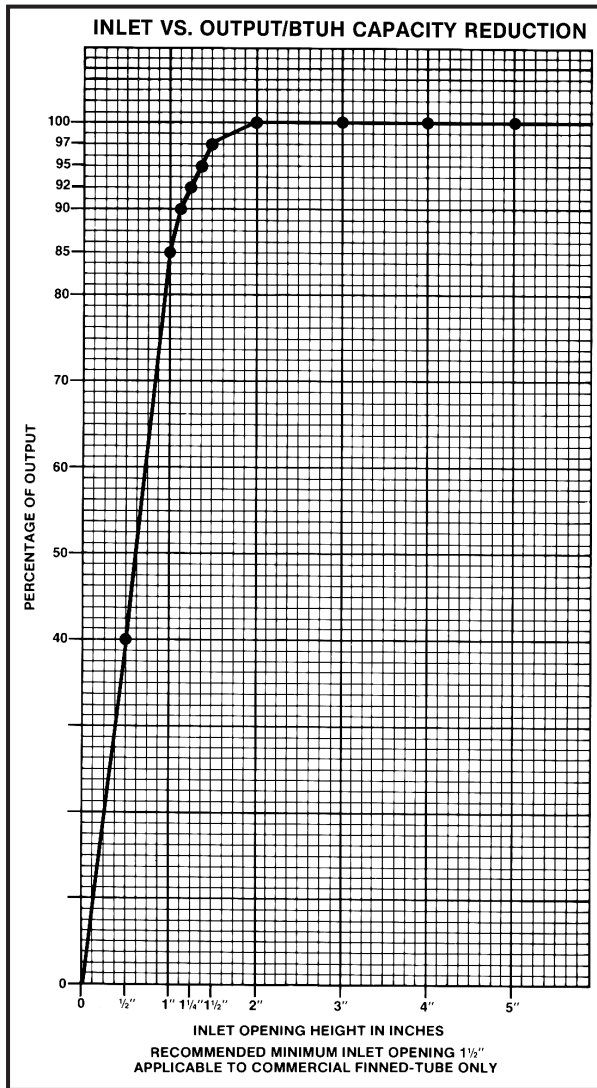

GUARANTEED WORKING PRESSURES

- 1" IPS — 780 AT TEMPERATURES UP TO 650°F.
 - 1 1/4" IPS — 660 AT TEMPERATURES UP TO 650°F.
 - 2" IPS — 405 AT TEMPERATURES UP TO 650°F.
 - 1 1/4" CU — 194 AT TEMPERATURES UP TO 300°F.
 - 1" CU — 204 AT TEMPERATURES UP TO 300°F.
 - 3/4" CU — 218 PSI AT TEMPERATURES UP TO 300°F.
- MAXIMUM PRESSURES AT OTHER TEMPERATURES ARE AVAILABLE UPON REQUEST.

RATE OF PITCH FOR STEAM 1/2" DROP OVER 20 FT. RUN.

PIPE WATER CAPACITIES AND QUANTITIES CIRCULATED AT VELOCITY OF 3* FEET PER SECOND			
Pipe Size	Gals. Per Linear Ft.	Gals./Min. @ 3' Sec. Vel.*	Lbs./Hr. @ 3' Sec. Vel.*
1/2"	.016	2.88	1440
3/4"	.023	4.14	2070
1"	.040	7.20	3600
1 1/4"	.063	11.34	5660
1 1/2"	.102	18.36	9160
2"	.170	30.60	15300
2 1/2"	.275	49.50	24850
3"	.390	70.20	35000

*3 Ft./Sec. Velocity is Basic for Hot Water Rating Factors Shown on this Page.

$$\text{VELOCITY FT./SEC.} = \frac{\text{LBS. PER HOUR}}{(\text{GALS. PER FT.}) (3600) (8.3)}$$

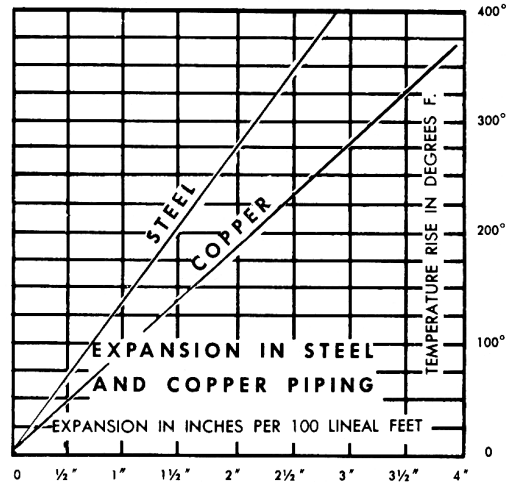

GLYCOL CORRECTION FACTORS

Fluid Temperature 200°F

% Solution	Ethylene Glycol	Propylene Glycol
20	.952	.988
30	.921	.968
40	.888	.943
50	.852	.912

Fluid Temperature 180°F

% Solution	Ethylene Glycol	Propylene Glycol
20	.946	.982
30	.913	.961
40	.879	.934
50	.842	.902

Fluid Temperature 140°F

% Solution	Ethylene Glycol	Propylene Glycol
20	.934	.97
30	.898	.946
40	.861	.916
50	.821	.881

ALTITUDE FACTORS

Approximate factors for convective heat value at varying altitudes

Altitude	Ferrous Units	Copper Alum. Units
Sea Level	1.000	1.000
1,000 ft.	.984	.969
2,000 ft.	.968	.938
3,000 ft.	.952	.908
4,000 ft.	.936	.878
5,000 ft.	.920	.850
6,000 ft.	.904	.822
7,000 ft.	.889	.795
8,000 ft.	.874	.768
9,000 ft.	.859	.743
10,000 ft.	.844	.718
15,000 ft.	.771	.603
20,000 ft.	.703	.502

Design Data

CORRECTION FACTORS FOR STEAM PRESSURES AND AIR TEMPERATURES OTHER THAN STANDARD

STEAM		ENTERING AIR TEMPERATURE, °F														
Pressure		Temp.			STD											
Gauge	Abs. Psi	°F	45	55	65	70	75	80	85	90	100	110	120	130	140	150
(Vac) 15" Hg	7.32	178.9	0.90	0.80	0.70	0.65	0.60	0.56	0.51	0.45	0.39	0.32	0.25	0.18	0.13	0.08
(Vac) 10"	9.78	192.2	1.02	0.91	0.81	0.76	0.71	0.66	0.62	0.55	0.48	0.40	0.33	0.26	0.20	0.14
(Vac) 5"	12.25	202.9	1.11	1.00	0.90	0.85	0.79	0.75	0.70	0.63	0.56	0.48	0.40	0.33	0.27	0.20
(Vac) 0 Psi	14.696	212.0	1.19	1.09	0.97	0.92	0.87	0.82	0.77	0.70	0.63	0.54	0.46	0.38	0.31	0.25
▶ .899	15.595	215.0	1.22	1.11	1.00	0.95	0.90	0.84	0.80	0.75	0.65	0.57	0.48	0.40	0.33	0.26
5	19.70	227.1	1.34	1.22	1.11	1.05	1.00	0.95	0.90	0.81	0.75	0.66	0.57	0.49	0.41	0.34
10	24.70	239.4	1.45	1.33	1.22	1.17	1.11	1.05	1.00	0.91	0.85	0.75	0.66	0.58	0.50	0.42
15	29.70	249.8	1.55	1.43	1.31	1.26	1.20	1.14	1.09	1.00	0.94	0.84	0.75	0.66	0.57	0.49
20	34.70	258.8	1.63	1.52	1.40	1.33	1.28	1.23	1.17	1.07	1.02	0.92	0.82	0.73	0.64	0.55
25	39.70	266.8	1.71	1.59	1.47	1.41	1.36	1.30	1.25	1.15	1.09	0.98	0.89	0.80	0.71	0.62
30	44.70	274.0	1.78	1.66	1.54	1.48	1.42	1.37	1.31	1.21	1.15	1.05	0.95	0.85	0.76	0.68
40	54.70	286.7	1.91	1.79	1.66	1.61	1.54	1.49	1.43	1.32	1.27	1.16	1.06	0.97	0.87	0.78
50	64.70	297.7	2.02	1.90	1.77	1.71	1.65	1.60	1.54	1.42	1.37	1.26	1.16	1.06	0.96	0.87
60	74.70	307.3	2.10	2.00	1.87	1.81	1.75	1.69	1.63	1.51	1.47	1.35	1.25	1.15	1.05	0.95
70	84.70	316.0	2.20	2.09	1.95	1.89	1.83	1.77	1.71	1.59	1.55	1.44	1.33	1.23	1.12	1.03
80	94.70	323.9	2.27	2.17	2.03	1.97	1.91	1.85	1.80	1.69	1.63	1.52	1.41	1.31	1.20	1.10
90	104.70	331.2	2.36	2.24	2.11	2.05	1.98	1.93	1.87	1.74	1.70	1.59	1.48	1.38	1.28	1.17
100	114.70	337.9	2.43	2.31	2.18	2.11	2.05	2.00	1.94	1.81	1.77	1.65	1.54	1.44	1.33	1.23
125	139.70	352.9	2.59	2.47	2.33	2.27	2.21	2.16	2.10	1.96	1.92	1.80	1.69	1.59	1.48	1.38
150	164.70	365.9	2.73	2.62	2.47	2.43	2.35	2.29	2.23	2.08	2.05	1.94	1.82	1.72	1.61	1.51
175	189.70	377.4	2.86	2.74	2.60	2.54	2.47	2.41	2.35	2.21	2.17	2.05	1.95	1.85	1.73	1.63
200	214.70	387.8	2.95	2.85	2.71	2.63	2.58	2.52	2.47	2.31	2.29	2.17	2.06	1.96	1.84	1.75

From Keenan and Keyes — Linear Interpolation.

Note: Gauge pressure should be corrected for altitude.

CORRECTION FACTORS FOR WATER TEMPERATURES AND AIR TEMPERATURES OTHER THAN STANDARD

AVERAGE WATER TEMP. °F	ENTERING AIR TEMPERATURE, °F														
	45	55	STD	70	75	80	85	90	95	100	110	120	130	140	150
90	.19	.13	.11	.06											
100	.25	.19	.15	.11	.08	.06									
110	.31	.25	.20	.16	.13	.11	.08	.06							
120	.38	.31	.26	.21	.19	.16	.13	.11	.08	.06					
130	.45	.38	.33	.28	.25	.21	.19	.16	.13	.11	.06				
140	.53	.45	.40	.34	.31	.28	.25	.21	.19	.16	.11	.06			
150	.61	.53	.45	.41	.38	.34	.31	.28	.25	.21	.16	.11	.06		
160	.69	.61	.53	.49	.45	.41	.38	.34	.31	.28	.21	.16	.11	.06	
170	.77	.69	.61	.57	.53	.49	.45	.41	.38	.34	.28	.21	.16	.11	.06
180	.86	.77	.69	.65	.61	.57	.53	.49	.45	.41	.34	.28	.21	.16	.11
190	.95	.86	.78	.73	.69	.65	.61	.57	.53	.49	.41	.34	.28	.21	.16
200	1.05	.95	.86	.82	.77	.73	.69	.65	.61	.57	.49	.41	.34	.28	.21
210	1.14	1.05	.95	.91	.86	.82	.77	.73	.69	.65	.57	.49	.41	.34	.28
▶ 215 (STD.)	1.19	1.09	1.00	.95	.91	.86	.82	.77	.73	.69	.61	.53	.45	.38	.31
220	1.24	1.14	1.05	1.00	.95	.91	.86	.82	.77	.73	.65	.57	.49	.41	.34
230	1.34	1.24	1.14	1.09	1.05	1.00	.95	.91	.86	.82	.73	.65	.57	.49	.41
240	1.44	1.34	1.25	1.19	1.14	1.09	1.05	1.00	.95	.91	.82	.73	.65	.57	.49
250	1.55	1.44	1.34	1.29	1.24	1.19	1.14	1.09	1.05	1.00	.91	.82	.73	.65	.57
260	1.66	1.55	1.44	1.39	1.34	1.29	1.24	1.19	1.14	1.09	1.00	.91	.82	.73	.65
270	1.76	1.66	1.55	1.50	1.44	1.39	1.34	1.29	1.24	1.19	1.09	1.00	.91	.82	.73
280	1.87	1.76	1.66	1.60	1.55	1.50	1.44	1.39	1.34	1.29	1.19	1.09	1.00	.91	.82
290	1.99	1.87	1.76	1.71	1.66	1.60	1.55	1.50	1.44	1.39	1.29	1.19	1.09	1.00	.91
300	2.10	1.99	1.87	1.82	1.76	1.71	1.66	1.60	1.55	1.50	1.39	1.29	1.19	1.09	1.00